

**PROCEDURES
FOR
AIR NAVIGATION SERVICES**

**RULES OF THE AIR
AND
AIR TRAFFIC SERVICES**

THIRTEENTH EDITION — 1996

This edition incorporates all amendments approved by the Council prior to 12 March 1996 and supersedes, on 7 November 1996, all previous editions of Doc 4444-RAC/501.

INTERNATIONAL CIVIL AVIATION ORGANIZATION

AMENDMENTS

The issue of amendments is announced regularly in the *ICAO Journal* and in the monthly *Supplement to the Catalogue of ICAO Publications and Audio-visual Training Aids*, which holders of this publication should consult. The space below is provided to keep a record of such amendments.

RECORD OF AMENDMENTS AND CORRIGENDA

| AMENDMENTS | | | |
|------------|-----------------|--------------|------------|
| No. | Date applicable | Date entered | Entered by |
| 1 | 6/11/97 | 17/9/97 | ICAO |
| 2 | 5/11/98 | 18/11/98 | ICAO |
| 3 | 4/11/99 | 10/9/99 | ICAO |
| | | | |
| | | | |
| | | | |
| | | | |
| | | | |
| | | | |
| | | | |
| | | | |
| | | | |
| | | | |
| | | | |
| | | | |
| | | | |
| | | | |
| | | | |
| | | | |
| | | | |
| | | | |
| | | | |
| | | | |

| CORRIGENDA | | | |
|------------|---------------|--------------|------------|
| No. | Date of issue | Date entered | Entered by |
| | | | |
| | | | |
| | | | |
| | | | |
| | | | |
| | | | |
| | | | |
| | | | |
| | | | |
| | | | |
| | | | |
| | | | |
| | | | |
| | | | |
| | | | |
| | | | |
| | | | |
| | | | |
| | | | |
| | | | |
| | | | |
| | | | |
| | | | |
| | | | |
| | | | |
| | | | |
| | | | |

TABLE OF CONTENTS

| | <i>Page</i> | | <i>Page</i> |
|---|--------------|---|-------------|
| FOREWORD | (vii) | Vertical separation | 3-1 |
| PART I. DEFINITIONS | 1-1 | 2. Vertical separation application | 3-1 |
| PART II. GENERAL PROVISIONS | 2-1 | 3. Vertical separation minimum | 3-1 |
| Scope of the Rules of the Air and Air | | 4. Minimum cruising level..... | 3-2 |
| Traffic Services Procedures | 2-1 | 5. Assignment of cruising levels..... | 3-2 |
| 1. Relationship to other documents | 2-1 | 6. Vertical separation during ascent or descent | 3-2 |
| 2. Contents of the document | 2-1 | Horizontal separation | 3-3 |
| Allocation of responsibility in the provision | | 7. Lateral separation..... | 3-3 |
| of air traffic services..... | 2-1 | 8. Longitudinal separation | 3-4 |
| 3. Responsibility for the provision of air | | Reduction in separation minima..... | 3-22 |
| 4. Responsibility for the provision of flight | 2-1 | 9. | 3-22 |
| 5. Division of responsibility for control | | Air traffic control clearances | 3-23 |
| 6. Responsibility in regard to military traffic | 2-2 | 10. Issuance of air traffic control clearances | 3-23 |
| 7. Responsibility in regard to unmanned | 2-3 | 11. Contents of air traffic control clearances | 3-24 |
| free balloons..... | 2-3 | 12. Description of air traffic control clearances | 3-24 |
| General air traffic services operating practices | 2-4 | 13. Clearances to fly maintaining own separation | |
| 8. Flight plan | 2-4 | while in visual meteorological conditions..... | 3-24 |
| 9. Change from IFR to VFR flight | 2-7 | 14. Essential traffic information | 3-25 |
| 10. Clearances and information | 2-8 | 15. Clearance of a requested change in | |
| 11. Control of air traffic flow | 2-8 | flight plan..... | 3-25 |
| 12. Altimeter setting procedures | 2-8 | Emergency and communication failure | 3-25 |
| 13. Indication of heavy wake turbulence | | 16. Emergency procedures..... | 3-25 |
| category and MLS capability..... | 2-9 | 17. Air-ground communication failure | 3-27 |
| 14. Position reporting | 2-10 | Other in-flight contingencies | 3-28 |
| 15. Reporting of operational and meteorological | | 18. Strayed or unidentified aircraft | 3-28 |
| information..... | 2-11 | 19. Interception of civil aircraft..... | 3-29 |
| 16. Forwarding of meteorological information | 2-13 | 20. Descents by supersonic aircraft due to | |
| 17. Air traffic incident report..... | 2-13 | solar cosmic radiation | 3-30 |
| 18. Change of radiotelephony call sign for aircraft | 2-13 | PART IV. APPROACH CONTROL | |
| 19. Procedures in regard to aircraft equipped | | SERVICE | 4-1 |
| with airborne collision avoidance | | 1. Reduction in separation minima | 4-1 |
| systems (ACAS)..... | 2-14 | Departing aircraft | 4-1 |
| PART III. AREA CONTROL SERVICE | 3-1 | 2. General procedures for departing aircraft | 4-1 |
| Separation of aircraft in the provision of | | 3. Minimum separation between departing aircraft | 4-1 |
| area control service..... | 3-1 | 4. Clearances for departing aircraft to climb | |
| 1. General provisions for the separation | | maintaining own separation while in visual | |
| of controlled traffic | 3-1 | meteorological conditions | 4-2 |
| | | 5. Departing aircraft from parallel or | |
| | | near-parallel runways..... | 4-2 |
| | | 6. Information for departing aircraft | 4-2 |

(iv)

| | Page | | Page |
|---|------------|--|-------------|
| Arriving aircraft | 4-3 | PART VI. RADAR SERVICES | 6-1 |
| 7. General procedures for arriving aircraft | 4-3 | 1. Radar systems capabilities | 6-1 |
| 8. Clearance to descend subject to maintaining own separation while in visual meteorological conditions | 4-4 | 2. Presentation of radar information | 6-2 |
| 9. Visual approach | 4-4 | 3. Communications | 6-2 |
| 10. Instrument approach | 4-4 | 4. Provision of radar services | 6-2 |
| 11. Holding | 4-4 | 5. Use of SSR transponders | 6-3 |
| 12. Approach sequence | 4-5 | 6. General radar procedures | 6-5 |
| 13. Arriving aircraft to parallel or near-parallel runways | 4-6 | 7. Use of radar in the air traffic control service | 6-9 |
| 14. Expected approach time | 4-10 | 8. Emergencies, hazards and equipment failures | 6-14 |
| 15. Information for arriving aircraft | 4-10 | 9. Use of radar in the approach control service | 6-16 |
| 16. Separation of departing aircraft from arriving aircraft | 4-11 | 10. Use of radar in the aerodrome control service | 6-21 |
| | | 11. Use of radar in the flight information service | 6-22 |
| PART V. AERODROME CONTROL SERVICE | 5-1 | PART VII. FLIGHT INFORMATION SERVICE AND ALERTING SERVICE | 7-1 |
| Functions of aerodrome control towers | 5-1 | 1. Flight information service | 7-1 |
| 1. General | 5-1 | 2. Alerting service | 7-4 |
| 2. Alerting service provided by aerodrome control towers | 5-1 | PART VIII. CO-ORDINATION | 8-1 |
| 3. Suspension of visual flight rules operations by aerodrome control towers | 5-1 | 1. General | 8-1 |
| Traffic and taxi circuits | 5-1 | 2. Co-ordination in respect of the provision of flight information service and alerting service | 8-1 |
| 4. Critical positions of aircraft in the aerodrome traffic and taxi circuits | 5-1 | 3. Co-ordination in respect of the provision of air traffic advisory service | 8-1 |
| 5. Selection of runway-in-use | 5-2 | 4. Co-ordination in respect of the provision of air traffic control service | 8-1 |
| Aeronautical ground lights | 5-2 | 5. Co-ordination between air traffic services units and aeronautical telecommunication stations | 8-5 |
| 6. Operation | 5-2 | PART IX. AIR TRAFFIC SERVICES MESSAGES | 9-1 |
| Information to aircraft by aerodrome control towers | 5-5 | 1. Categories of messages | 9-1 |
| 7. Information related to the operation of aircraft | 5-5 | 2. General provisions | 9-2 |
| 8. Information on aerodrome conditions | 5-6 | 3. Methods of message exchange | 9-4 |
| Control of aerodrome traffic | 5-6 | 4. Message types and their application | 9-5 |
| 9. Order of priority for arriving and departing aircraft | 5-6 | PART X. PHRASEOLOGIES | 10-1 |
| 10. Control of taxiing aircraft | 5-7 | 1. Communications procedures | 10-1 |
| 11. Control of other than aircraft traffic on the manoeuvring area | 5-9 | 2. General | 10-1 |
| 12. Separation of aircraft and of aircraft and vehicles on the manoeuvring area | 5-10 | 3. Phraseologies | 10-2 |
| 13. Control of traffic in the traffic circuit | 5-10 | 4. Radar phraseologies | 10-23 |
| 14. Control of departing aircraft | 5-10 | PART XI. CONTROLLER-PILOT DATA LINK COMMUNICATIONS (CPDLC) | 11-1 |
| 15. Control of arriving aircraft | 5-12 | 1. General | 11-1 |
| 16. Wake turbulence categorization of aircraft and increased longitudinal separation minima | 5-12 | 2. Communication procedures | 11-1 |
| 17. Authorization of special VFR flights | 5-13 | | |

| | <i>Page</i> | | <i>Page</i> |
|---|-------------|---|-------------|
| APPENDICES | | | |
| APPENDIX 1. Instructions for air-reporting by voice communications | A1-1 | APPENDIX 3. Air Traffic Services Messages | A3-1 |
| 1. Reporting instructions | A1-2 | 1. Message contents, formats and data conventions | A3-2 |
| 2. Special air-report of volcanic activity form (Model VAR) | A1-5 | 2. Examples of ATS messages | A3-31 |
| 3. Examples | A1-6 | APPENDIX 4. Air Traffic Incident Report | A4-1 |
| APPENDIX 2. Flight Plan | A2-1 | 1. ICAO model air traffic incident report form | A4-2 |
| 1. ICAO model flight plan form | A2-2 | 2. Instructions for the completion of the air traffic incident report form | A4-6 |
| 2. Instructions for the completion of the flight plan form | A2-3 | <i>Note 1.— Texts of Attachments F and K deleted by Amendment 6 to the 11th Edition.</i> | |
| 3. Instructions for the transmission of a filed flight plan (FPL) message | A2-10 | <i>Note 2.— Texts of Attachments A, B, C, D, E, G, H, I, J, L and M deleted by Amendment 2 to the 12th Edition. This material now appears in the Air Traffic Services Planning Manual (Doc 9426).</i> | |
| 4. Instructions for the transmission of a supplementary flight plan (SPL) message | A2-10 | APPENDIX 5. Controller-Pilot Data Link Communications (CPDLC) Message Set | A5-1 |
| 5. Example of a completed flight plan form | A2-11 | 1. Uplink messages | A5-2 |
| 6. ICAO model repetitive flight plan (RPL) listing form | A2-12 | 2. Downlink messages | A5-19 |
| 7. Instructions for the completion of the repetitive flight plan (RPL) listing form | A2-13 | | |
| 8. Example of a completed repetitive flight plan (RPL) listing form | A2-16 | | |

FOREWORD

1. Historical background

1.1 The *Procedures for Air Navigation Services — Rules of the Air and Air Traffic Services* (PANS-RAC) are the result of the progressive evolution of the *Procedures for Air Navigation Services — Air Traffic Control* (PANS-ATC) prepared by the Air Traffic Control Committee of the International Conference on North Atlantic Route Service Organization (Dublin, March 1946).

1.2 A second version of the PANS-ATC was issued in the same year, following review of the original procedures by the International Conference on European-Mediterranean Route Service Organization (Paris, April-May 1946).

1.3 The Third Edition of the PANS-ATC was prepared in 1947 by the Rules of the Air and Air Traffic Control (RAC) Division at its Second Session (Montreal, December 1946-January 1947).

1.4 Originally applicable on a regional basis, the PANS-ATC became applicable on a world-wide basis on 1 February 1950.

1.5 The Fourth Edition (1951) was given its present title *Procedures for Air Navigation Services — Rules of the Air and Air Traffic Services* (PANS-RAC) on the recommendation of the Fourth Session of the Rules of the Air and Air Traffic Control (RAC) Division (Montreal, November-December 1950). The new title reflects the fact that certain procedures applicable to pilots and a number of procedures relating to the provision of flight information and alerting service were included therein, in addition to the operation of the air traffic control service.

1.6 New editions were issued subsequently. The origin of each edition issued since 1946 and subsequent amendments thereto are shown in Table A, together with a list of the principal subjects involved, the dates on which the amendments were approved by the Council and the dates on which they became applicable.

2. Scope and purpose

2.1 The *Procedures for Air Navigation Services — Rules of the Air and Air Traffic Services* (PANS-RAC) are

complementary to the Standards and Recommended Practices contained in Annex 2 — *Rules of the Air* and in Annex 11 — *Air Traffic Services*. They are supplemented when necessary by regional procedures contained in the *Regional Supplementary Procedures* (Doc 7030).

2.2 The *Procedures for Air Navigation Services — Rules of the Air and Air Traffic Services* (PANS-RAC) specify, in greater detail than in the Standards and Recommended Practices, the actual procedures to be applied by air traffic services units in providing the various air traffic services to air traffic.

3. Status

3.1 The Procedures for Air Navigation Services (PANS) do not have the same status as the Standards and Recommended Practices. While the latter are *adopted* by Council in pursuance of Article 37 of the Convention on International Civil Aviation, subject to the full procedure of Article 90, the PANS are *approved* by the Council and recommended to Contracting States for world-wide application.

3.2 Whilst the PANS may contain material which may eventually become Standards or Recommended Practices (SARPs) when it has reached the maturity and stability necessary for adoption as such, they may also comprise material prepared as an amplification of the basic principles in the corresponding SARPs, and designed particularly to assist the user in the application of those SARPs.

4. Implementation

4.1 The implementation of procedures is the responsibility of Contracting States; they are applied in actual operations only after, and in so far as, States have enforced them. However, with a view to facilitating their processing towards implementation by States, they have been prepared in language which will permit direct use by air traffic services personnel and others associated with the provision of air traffic services to international air navigation.

5. Publication of differences

5.1 The PANS do not carry the status afforded to Standards adopted by the Council as Annexes to the Convention and, therefore, do not come within the obligation imposed by Article 38 of the Convention to notify differences in the event of non-implementation.

5.2 However, attention of States is drawn to the provision of Annex 15 related to the publication in their Aeronautical Information Publications of lists of significant

differences between their procedures and the related ICAO procedures.

6. Promulgation of information

6.1 Information relating to the establishment and withdrawal of and changes to facilities, services and procedures affecting aircraft operations provided according to the Procedures specified in this document should be notified and take effect in accordance with Annex 15.

Table A. Amendments to the PANS-RAC

| <i>Amendment</i> | <i>Source(s)</i> | <i>Subject(s)</i> | <i>Approved Applicable</i> |
|--------------------|--|--|---|
| 1st Edition (1946) | North Atlantic Route Conference (1946) | <i>Procedures for Air Navigation Services — Air Traffic Control</i> (PANS-ATC). |)) Implemented on a) regional basis on) various dates and) applicable from) 1 February 1950 on a) world-wide basis.)) |
| 2nd Edition (1946) | Conference on European-Mediterranean Route Service Organization (1946) | Revision of the original procedures. | |
| 3rd Edition (1947) | Rules of the Air and Air Traffic Control (RAC) Division, Second Session (1946/1947) | Revision of the second edition. | |
| 4th Edition | Rules of the Air and Air Traffic Control (RAC) Division, Fourth Session (1950) | <i>Procedures for Air Navigation Services — Rules of the Air and Air Traffic Services</i> (PANS-RAC). Inclusion of procedures applicable to pilots and of procedures regarding the provision of flight information and alerting service; change of title to reflect these inclusions. | 28 November 1951 1 September 1952 |
| 5th Edition | First Air Navigation Conference (1953); AGA Division, Fifth Session (1952) | Position reporting procedures; holding procedures phraseology; radar approach control procedures and phraseology; operation of aeronautical ground lights; air-ground communications failure; air reports; flight plan AIREP and POMAR forms. | 8 December 1953 1 September 1954 |
| 6th Edition | Second Air Navigation Conference (1955) | Separation minima; VFR on-top; co-ordination between adjacent area control centres; objectives and functions of air traffic advisory service; alerting service and search and rescue service; POMAR form. | 11 May 1956 1 December 1956 |
| 7th Edition | Rules of the Air, Air Traffic Services and Search and Rescue (RAC/SAR) Division (1958) | Introduction of a new flight plan form; major revision of the provisions relating to flight plans and the issuance of clearances based thereon; revision of flight plan messages; standardized content for messages relating to emergency phases; changes to the separation minima requirements; contents of position reports; restrictions in the issuance of clearances to fly maintaining VMC; transfer of responsibility for control from one ATC unit to another; procedures for approach control service; objectives and functions of the air traffic advisory service; phraseologies for ATS; consolidation of all provisions regarding flight plans, the flight plan form and instructions for completion of same. | 18 February 1960 1 August 1960 |

| <i>Amendment</i> | <i>Source(s)</i> | <i>Subject(s)</i> | <i>Approved Applicable</i> |
|---------------------------------|--|---|--------------------------------------|
| Amendment 1 to the 7th Edition | Panel for Co-ordinating Procedures respecting the Supply of Information for Aircraft Information, First Meeting (1959); Meteorology Division, Fifth Session (1959) | Transmission of meteorological information to aircraft in flight; revision of the Air-report and AIREP form. | 2 December 1960 1 July 1961 |
| Amendment 2 to the 7th Edition | Air Navigation Commission | Altimeter setting procedures. | 26 June 1961 1 October 1961 |
| Amendment 3 to the 7th Edition | Air Navigation Commission | Change to flight plan form to cater for flights through intermediate stops. | 15 December 1961 1 July 1962 |
| Amendment 4 to the 7th Edition | Air Navigation Commission | Additional provisions relating to alerting service. | 13 April 1962 1 November 1962 |
| Amendment 5 to the 7th Edition | Air Navigation Commission | Changes and additions to the provisions relating to the operation of aeronautical ground lights. | 12 December 1962 1 March 1963 |
| Amendment 6 to the 7th Edition | Air Navigation Commission | Definition for "D-value". | 8 April 1963 1 November 1963 |
| Amendment 7 to the 7th Edition | Meteorological and Operations (MET/OPS) Divisional Meeting (1964) | Aircraft meteorological observations and reports. | 31 May 1965 10 March 1966 |
| 8th Edition | Rules of the Air and Air Traffic Services/Operations (RAC/OPS) Divisional Meeting (1963); Air Traffic Control Automation Panel (ATCAP), Fourth Meeting (1964) | New separation criteria and minima; control of VFR flights; essential traffic information; air traffic services co-ordination; phraseology including radar phraseology. | 29 November 1965 25 August 1966 |
| Amendment 1 to the 8th Edition | Air Navigation Commission | Introduction of a new part on the use of radar in air traffic services and consequential changes to other parts. Expression of vertical position. | 20 February 1967 24 August 1967 |
| 9th Edition | Air Traffic Control Automation Panel (ATCAP), Fifth Meeting (1966) | Changes to the provisions concerning air traffic services data to facilitate the application of automation in air traffic control; guidance material on ATC automation and flow control. | 7 June 1967 8 February 1968 |
| Amendment 1 to the 9th Edition | Fifth Air Navigation Conference (1967) | Changes to all parts to improve the safety and efficiency of international air operations in the approach, landing and take-off phases. | 23 January 1969 18 September 1969 |
| 10th Edition | Sixth Air Navigation Conference (1969) | Position reporting and reporting of operational and meteorological information; types of flights to be provided with separation; VMC clearances; Mach number technique; use of SSR in the air traffic services; application of separation minima; clearances; addressing of ATS messages; flight information service and alerting service; guidance material on the application of the Mach number technique on the use of secondary surveillance radar in the air traffic services and on a standard form and attendant procedures for the reporting of air traffic incidents. | 1 June 1970 4 February 1971 |
| Amendment 1 to the 10th Edition | Sixth Air Navigation Conference (1969); LIM EUM (RAC/COM) RAN Meeting (1969) | Changes to the format and data conventions for air-report messages. Estimated time of departure/arrival in ATS messages. | 24 March 1972 7 December 1972 |
| Amendment 2 to the 10th Edition | Air Navigation Commission | Authority over aircraft operating over the high seas. | 15 November 1972 16 August 1973 |
| Amendment 3 to the 10th Edition | Air Navigation Commission | Guidance material on repetitive flight plans. | 13 December 1972 16 August 1973 |

| <i>Amendment</i> | <i>Source(s)</i> | <i>Subject(s)</i> | <i>Approved Applicable</i> |
|---------------------------------|---|---|--------------------------------------|
| Amendment 4 to the 10th Edition | Seventh Air Navigation Conference (1972) | Area navigation practices; position reports; SSR radiotelephony phraseology; guidance material on the use of SSR. | 23 March 1973 23 May 1974 |
| Amendment 5 to the 10th Edition | Council action in pursuance of Assembly Resolutions A17-10 and A18-10 | ATS practices in the event an aircraft is being subjected to unlawful interference. | 7 December 1973 23 May 1974 |
| Amendment 6 to the 10th Edition | Various sources including Sixth EUM/RAN Meeting, a proposal by the United Kingdom, various actions of the Council and the Air Navigation Commission | Altimeter setting; radar identification and transfer; automatic terminal information service (ATIS); communication failure procedures. | 8 April 1974 27 February 1975 |
| Amendment 7 to the 10th Edition | Technical Panel on Supersonic Transport Operations; Air Navigation Commission; Council | Supersonic aircraft operations; interception of aircraft; definition of "emergency phase". | 4 February 1975 9 October 1975 |
| Amendment 8 to the 10th Edition | Air Navigation Commission; Amendments to Annexes 3 and 10 | SSR Code 7500; information to aircraft and air-reporting by aircraft; frequencies for survival radio equipment. | 12 December 1975 30 December 1976 |
| Amendment 9 to the 10th Edition | Technical Panel on Supersonic Transport Operations; Air Navigation Commission; Amendment to Annex 14 | Supersonic aircraft operations; unlawful interference. | 7 April 1976 30 December 1976 |
| 11th Edition | Ninth Air Navigation Conference (1976); Air Navigation Commission; Amendments to Annexes 3 and 14 | Definitions; ATS flight plans and messages; guidance material regarding repetitive flight plans; separation between aircraft; guidance material regarding wake turbulence and related separation minima; use of information derived from secondary surveillance radar; guidance material concerning radar separation based on computer-processed radar data; operation of aeronautical ground lights. | 9 December 1977 10 August 1978 |
| Amendment 1 to the 11th Edition | Air Navigation Commission | Designation of standard departure and arrival routes. | 3 December 1979 27 November 1980 |
| Amendment 2 to the 11th Edition | Air Navigation Commission | Definitions; co-ordination of activities which constitute a potential hazard to flights of civil aircraft; unmanned free balloons. | 4 March 1981 26 November 1981 |
| Amendment 3 to the 11th Edition | Air Navigation Commission | Action to be taken by an ATS unit when it becomes aware that an aircraft has deviated from its intended track or reports that it is lost. | 1 April 1981 26 November 1981 |
| Amendment 4 to the 11th Edition | Amendment 29 to Annex 11 | Automatic terminal information service (ATIS); transferred to Annex 11. | 2 April 1982 25 November 1982 |
| Amendment 5 to the 11th Edition | AGA Divisional Meeting (1981); ATS Data Acquisition, Processing and Transfer Panel, Third Meeting (1981); Air Navigation Commission | Definitions; wind shear; surface movement guidance and control; message priority; radiotelephony phraseologies; communications requirements; units of measurement. | 13 May 1983 7 June 1984 |
| 12th Edition | ATS Data Acquisition, Processing and Transfer Panel, Third Meeting (1981); Air Navigation Commission | Definitions; contents of flight plans; repetitive flight plans; ATS data interchange; Co-ordinated Universal Time (UTC). | 26 June 1984 21 November 1985 |
| Amendment 1 to the 12th Edition | Council; Air Navigation Commission | Strayed or unidentified aircraft; interception of civil aircraft; provision of flight plan and flight progress information; use of radar. | 14 March 1986 20 November 1986 |

| <i>Amendment</i> | <i>Source(s)</i> | <i>Subject(s)</i> | <i>Approved Applicable</i> |
|---------------------------------|--|---|--------------------------------------|
| Amendment 2 to the 12th Edition | Air Navigation Commission | Definitions; position and air-reporting; change of aircraft call signs during flight; airborne SSR Mode S capability; reporting of volcanic activity; introduction of three-letter designators; transmission of numbers on radiotelephony; inclusion of English language phraseology in the French, Russian and Spanish editions; deletion of all attachments. | 27 March 1987 22 October 1987 |
| Amendment 3 to the 12th Edition | Secretariat; Visual Flight Rules Operations Panel (VFOP), Third Meeting (1986); Air Navigation Commission; amendments consequential to adoption of amendments to Annex 6 | Operation of aircraft in mixed VFR/IFR environments; surface movement guidance and control; simultaneous operations on parallel or near-parallel instrument runways; acts of unlawful interference; wake turbulence categories and separation minima. | 19 March 1990 14 November 1991 |
| Amendment 4 to the 12th Edition | Secondary Surveillance Radar Improvements and Collision Avoidance Systems Panel, Fourth Meeting (SICASP/4) (1989) | Definitions; provision of air traffic services irrespective of airborne collision avoidance system (ACAS) operation. | 26 February 1993 11 November 1993 |
| Amendment 5 to the 12th Edition | Review of the General Concept of Separation Panel (RGCSP), Seventh Meeting (1990), Eighth Meeting (1993); Automatic Dependent Surveillance Panel (ADSP), Second Meeting (1992); All Weather Operations Panel (AWOP), Twelfth Meeting (1987); SSR Improvements and Collision Avoidance Systems Panel (SICASP), Fourth Meeting (1989); Obstacle Clearance Panel (OCP), Ninth Meeting (1990); Limited North Atlantic (COM/MET/RAC) Regional Air Navigation Meeting (1992); COM/MET/OPS Divisional Meeting (1990); Air Navigation Commission | Definitions; reduced vertical separation minimum of 300 m (1 000 ft) above FL 290; area navigation (RNAV) criteria; required navigation performance; automatic dependent surveillance; identification of medical aircraft; integration of helicopter traffic with conventional aeroplane traffic; inclusion of en-route alternates on the flight plan; surface movement radar; air traffic incident reporting; air reporting procedures; transmission of information to aircraft on radioactive material and toxic chemical "clouds"; meteorological information in ATS messages; identification of runway visual range (RVR) reporting position; ATS aspects of MLS operations; use of SSR alone for separation purposes; ground proximity warning systems (GPWS). | 18 March 1994 10 November 1994 |
| Amendment 6 to the 12th Edition | Air Navigation Commission | Simultaneous operations on parallel or near-parallel instrument runways. | 13 March 1995 9 November 1995 |
| 13th Edition | Secretariat; SSR Improvements and Collision Avoidance Systems Panel (SICASP), Fifth Meeting (1993); All Weather Operations Panel | Use of radar in air traffic services; airborne collision avoidance systems (ACAS); approach instructions for microwave landing system (MLS)/area navigation (RNAV) procedures. | 21 March 1996 7 November 1996 |
| Amendment 1 to the 13th Edition | Air Navigation Commission | Definitions; AIREP formats and automated air reporting; forwarding of meteorological information; separation between aircraft; adequacy of distress and urgency communication procedures; and communication failure procedures. | 5 March 1997 6 November 1997 |
| Amendment 2 to the 13th Edition | Automatic Dependent Surveillance Panel, Fourth Meeting (1996); Review of the General Concept of Separation Panel, Ninth Meeting (1996) | Automatic dependent surveillance; data interchange between automatic ATS systems; ATS applications for air-ground data links; separation between aircraft; required navigation performance; and required navigation performance and area navigation for en-route operations. | 19 March 1998 5 November 1998 |
| Amendment 3 to the 13th Edition | Air Navigation Commission; Visual Aids Panel, Thirteenth Meeting (1997) | ATS airspace classifications; visual meteorological conditions clearance; and runway-holding position. | 10 March 1999 4 November 1999 |

PROCEDURES FOR AIR NAVIGATION SERVICES

PART I. DEFINITIONS

Note.— Throughout the text of this document the term “service” is used as an abstract noun to designate functions, or service rendered; the term “unit” is used to designate a collective body performing a service.

When the following terms are used in the present document they have the following meanings:

Accepting unit/controller. Air traffic control unit/air traffic controller next to take control of an aircraft.

Note.— See definition of “transferring unit/controller”.

ADS agreement. An ADS reporting plan which establishes the conditions of ADS data reporting (i.e. data required by the air traffic services unit and frequency of ADS reports which have to be agreed to prior to the provision of the ADS services).

Note.— The terms of the agreement will be exchanged between the ground system and the aircraft by means of a contract, or a series of contracts.

ADS contract. A means by which the terms of an ADS agreement will be exchanged between the ground system and the aircraft, specifying under what conditions ADS reports would be initiated, and what data would be contained in the reports.

Note.— The term “ADS contract” is a generic term meaning variously, ADS event contract, ADS demand contract, ADS periodic contract or an emergency mode. Ground forwarding of ADS reports may be implemented between ground systems.

ADS service. A service using aircraft information provided by means of automatic dependent surveillance.

Advisory airspace. An airspace of defined dimensions, or designated route, within which air traffic advisory service is available.

Advisory route. A designated route along which air traffic advisory service is available.

Note.— Air traffic control service provides a much more complete service than air traffic advisory service; advisory areas and routes are therefore not established within controlled airspace, but air traffic advisory service may be provided below and above control areas.

Aerodrome. A defined area on land or water (including any buildings, installations and equipment) intended to be used either wholly or in part for the arrival, departure and surface movement of aircraft.

Note.— The term “aerodrome” where used in the provisions relating to flight plans and ATS messages is intended to cover also sites other than aerodromes which may be used by certain types of aircraft, e.g. helicopters or balloons.

Aerodrome control service. Air traffic control service for aerodrome traffic.

Aerodrome control tower. A unit established to provide air traffic control service to aerodrome traffic.

Aerodrome elevation. The elevation of the highest point of the landing area.

Aerodrome taxi circuit. The specified path of aircraft on the manoeuvring area during specific wind conditions.

Aerodrome traffic. All traffic on the manoeuvring area of an aerodrome and all aircraft flying in the vicinity of an aerodrome.

Note.— An aircraft is in the vicinity of an aerodrome when it is in, entering or leaving an aerodrome traffic circuit.

Aerodrome traffic circuit. The specified path to be flown by aircraft operating in the vicinity of an aerodrome.

Aeronautical fixed service (AFS). A telecommunication service between specified fixed points provided primarily for the safety of air navigation and for the regular, efficient and economical operation of air services.

Aeronautical fixed station. A station in the aeronautical fixed service.

Aeronautical ground light. Any light specially provided as an aid to air navigation, other than a light displayed on an aircraft.

Aeronautical Information Publication (AIP). A publication issued by or with the authority of a State and containing aeronautical information of a lasting character essential to air navigation.

Aeronautical mobile service. A mobile service between aeronautical stations and aircraft stations, or between aircraft stations, in which survival craft stations may participate; emergency position-indicating radiobeacon stations may also participate in this service on designated distress and emergency frequencies.

Aeronautical station. A land station in the aeronautical mobile service. In certain instances, an aeronautical station may be located, for example, on board ship or on a platform at sea.

Aeronautical telecommunication service. A telecommunication service provided for any aeronautical purpose.

Aeronautical telecommunication station. A station in the aeronautical telecommunication service.

Airborne collision avoidance system (ACAS). An aircraft system based on secondary surveillance radar (SSR) transponder signals which operates independently of ground-based equipment to provide advice to the pilot on potential conflicting aircraft that are equipped with SSR transponders.

Aircraft. Any machine that can derive support in the atmosphere from the reactions of the air other than the reactions of the air against the earth's surface.

Aircraft address. A unique combination of 24 bits available for assignment to an aircraft for the purpose of air-ground communications, navigation and surveillance.

Aircraft identification. A group of letters, figures or a combination thereof which is either identical to, or the

Rules of the Air and Air Traffic Services (PANS-RAC)

coded equivalent of, the aircraft call sign to be used in air-ground communications, and which is used to identify the aircraft in ground-ground air traffic services communications.

Aircraft observation. The evaluation of one or more meteorological elements made from an aircraft in flight.

Aircraft proximity. A situation in which, in the opinion of a pilot or air traffic services personnel, the distance between aircraft as well as their relative positions and speed have been such that the safety of the aircraft involved may have been compromised. An aircraft proximity is classified as follows:

Risk of collision. The risk classification of an aircraft proximity in which serious risk of collision has existed.

Safety not assured. The risk classification of an aircraft proximity in which the safety of the aircraft may have been compromised.

No risk of collision. The risk classification of an aircraft proximity in which no risk of collision has existed.

Risk not determined. The risk classification of an aircraft proximity in which insufficient information was available to determine the risk involved, or inconclusive or conflicting evidence precluded such determination.

Air-ground communication. Two-way communication between aircraft and stations or locations on the surface of the earth.

Air-ground control radio station. An aeronautical telecommunication station having primary responsibility for handling communications pertaining to the operation and control of aircraft in a given area.

AIRMET information. Information issued by a meteorological watch office concerning the occurrence or expected occurrence of specified en-route weather phenomena which may affect the safety of low-level aircraft operations and which was not already included in the forecast issued for low-level flights in the flight information region concerned or sub-area thereof.

AIRPROX. The code word used in an air traffic incident report to designate aircraft proximity.

Air-report. A report from an aircraft in flight prepared in conformity with requirements for position, and operational and/or meteorological reporting.

Air-taxiing. Movement of a helicopter/VTOL above the surface of an aerodrome, normally in ground effect and at a ground speed normally less than 37 km/h (20 kt).

Note.— The actual height may vary, and some helicopters may require air-taxiing above 8 m (25 ft) AGL to reduce ground effect turbulence or provide clearance for cargo slingloads.

Air-to-ground communication. One-way communication from aircraft to stations or locations on the surface of the earth.

Air traffic. All aircraft in flight or operating on the manoeuvring area of an aerodrome.

Air traffic advisory service. A service provided within advisory airspace to ensure separation, in so far as practical, between aircraft which are operating on IFR flight plans.

Air traffic control clearance. Authorization for an aircraft to proceed under conditions specified by an air traffic control unit.

Note 1.— For convenience, the term “air traffic control clearance” is frequently abbreviated to “clearance” when used in appropriate contexts.

Note 2.— The abbreviated term “clearance” may be prefixed by the words “taxi”, “take-off”, “departure”, “en-route”, “approach” or “landing” to indicate the particular portion of flight to which the air traffic control clearance relates.

Air traffic control instruction. Directives issued by air traffic control for the purpose of requiring a pilot to take a specific action.

Air traffic control service. A service provided for the purpose of:

- a) preventing collisions:
 - 1) between aircraft, and
 - 2) on the manoeuvring area between aircraft and obstructions; and

- b) expediting and maintaining an orderly flow of air traffic.

Air traffic control unit. A generic term meaning variously, area control centre, approach control office or aerodrome control tower.

Air traffic service. A generic term meaning variously, flight information service, alerting service, air traffic advisory service, air traffic control service (area control service, approach control service or aerodrome control service).

Air traffic services airspaces. Airspaces of defined dimensions, alphabetically designated, within which specific types of flights may operate and for which air traffic services and rules of operation are specified.

Note.— ATS airspaces are classified as Class A to G as shown in Annex 11, Appendix 4.

Air traffic services reporting office. A unit established for the purpose of receiving reports concerning air traffic services and flight plans submitted before departure.

Note.— An air traffic services reporting office may be established as a separate unit or combined with an existing unit, such as another air traffic services unit, or a unit of the aeronautical information service.

Air traffic services unit. A generic term meaning variously, air traffic control unit, flight information centre or air traffic services reporting office.

Airway. A control area or portion thereof established in the form of a corridor.

ALERFA. The code word used to designate an alert phase.

Alerting service. A service provided to notify appropriate organizations regarding aircraft in need of search and rescue aid, and assist such organizations as required.

Alert phase. A situation wherein apprehension exists as to the safety of an aircraft and its occupants.

Allocation, allocate. Distribution of frequencies, SSR Codes, etc. to a State, unit or service. Distribution of 24-bit aircraft addresses to a State or common mark registering authority.

Alphanumeric characters (alphanumerics). A collective term for letters and figures (digits).

Alternate aerodrome. An aerodrome to which an aircraft may proceed when it becomes either impossible or inadvisable to proceed to or to land at the aerodrome of intended landing. Alternate aerodromes include the following:

Take-off alternate. An alternate aerodrome at which an aircraft can land should this become necessary shortly after take-off and it is not possible to use the aerodrome of departure.

En-route alternate. An aerodrome at which an aircraft would be able to land after experiencing an abnormal or emergency condition while en route.

Destination alternate. An alternate aerodrome to which an aircraft may proceed should it become either impossible or inadvisable to land at the aerodrome of intended landing.

Note.— The aerodrome from which a flight departs may also be an en-route or a destination alternate aerodrome for that flight.

Altitude. The vertical distance of a level, a point or an object considered as a point, measured from mean sea level.

Approach control office. A unit established to provide air traffic control service to controlled flights arriving at, or departing from, one or more aerodromes.

Approach control service. Air traffic control service for arriving or departing controlled flights.

Approach funnel. A specified airspace around a nominal approach path within which an aircraft approaching to land is considered to be making a normal approach.

Approach sequence. The order in which two or more aircraft are cleared to approach to land at the aerodrome.

Appropriate ATS authority. The relevant authority designated by the State responsible for providing air traffic services in the airspace concerned.

Appropriate authority.

- a) Regarding flight over the high seas: the relevant authority of the State of Registry.
- b) Regarding flight other than over the high seas: the relevant authority of the State having sovereignty over the territory being overflown.

Rules of the Air and Air Traffic Services (PANS-RAC)

Apron. A defined area, on a land aerodrome, intended to accommodate aircraft for purposes of loading or unloading passengers, mail or cargo, fuelling, parking or maintenance.

Area control centre. A unit established to provide air traffic control service to controlled flights in control areas under its jurisdiction.

Area control service. Air traffic control service for controlled flights in control areas.

Area navigation (RNAV). A method of navigation which permits aircraft operation on any desired flight path within the coverage of station-referenced navigation aids or within the limits of the capability of self-contained aids, or a combination of these.

Area navigation route. An ATS route established for the use of aircraft capable of employing area navigation.

Assignment, assign. Distribution of frequencies to stations. Distribution of SSR Codes or 24-bit aircraft addresses to aircraft.

ATIS. The symbol used to designate automatic terminal information service.

ATS route. A specified route designed for channelling the flow of traffic as necessary for the provision of air traffic services.

Note 1.— The term “ATS route” is used to mean variously, airway, advisory route, controlled or uncontrolled route, arrival or departure route, etc.

Note 2.— An ATS route is defined by route specifications which include an ATS route designator, the track to or from significant points (way-points), distance between significant points, reporting requirements and, as determined by the appropriate ATS authority, the lowest safe altitude.

Automatic dependent surveillance (ADS). A surveillance technique in which aircraft automatically provide, via a data link, data derived from on-board navigation and position-fixing systems, including aircraft identification, four-dimensional position and additional data as appropriate.

Automatic terminal information service (ATIS). The automatic provision of current, routine information to

arriving and departing aircraft throughout 24 hours or a specified portion thereof:

Data link-automatic terminal information service (D-ATIS). The provision of ATIS via data link.

Voice-automatic terminal information service (Voice-ATIS). The provision of ATIS by means of continuous and repetitive voice broadcasts.

Base turn. A turn executed by the aircraft during the initial approach between the end of the outbound track and the beginning of the intermediate or final approach track. The tracks are not reciprocal.

Note.— Base turns may be designated as being made either in level flight or while descending, according to the circumstances of each individual procedure.

Blind transmission. A transmission from one station to another station in circumstances where two-way communication cannot be established but where it is believed that the called station is able to receive the transmission.

Broadcast. A transmission of information relating to air navigation that is not addressed to a specific station or stations.

Ceiling. The height above the ground or water of the base of the lowest layer of cloud below 6 000 m (20 000 ft) covering more than half the sky.

Clearance limit. The point to which an aircraft is granted an air traffic control clearance.

Code (SSR). The number assigned to a particular multiple pulse reply signal transmitted by a transponder in Mode A or Mode C.

Computer. A device which performs sequences of arithmetical and logical steps upon data without human intervention.

Note.— When the word “computer” is used in this document it may denote a computer complex, which includes one or more computers and peripheral equipment.

Control area. A controlled airspace extending upwards from a specified limit above the earth.

Controlled aerodrome. An aerodrome at which air traffic control service is provided to aerodrome traffic.

Note.— The term “controlled aerodrome” indicates that air traffic control service is provided to aerodrome traffic but does not necessarily imply that a control zone exists.

Controlled airspace. An airspace of defined dimensions within which air traffic control service is provided in accordance with the airspace classification.

Note.— Controlled airspace is a generic term which covers ATS airspace Classes A, B, C, D and E as described in Annex 11, 2.6.

Controlled flight. Any flight which is subject to an air traffic control clearance.

Controller-pilot data link communications (CPDLC). A means of communication between controller and pilot, using data link for ATC communications.

Control zone. A controlled airspace extending upwards from the surface of the earth to a specified upper limit.

Cruise climb. An aeroplane cruising technique resulting in a net increase in altitude as the aeroplane mass decreases.

Cruising level. A level maintained during a significant portion of a flight.

Current flight plan. The flight plan, including changes, if any, brought about by subsequent clearances.

Note.— When the word “message” is used as a suffix to this term, it denotes the content and format of the current flight plan data sent from one unit to another.

Data convention. An agreed set of rules governing the manner or sequence in which a set of data may be combined into a meaningful communication.

Data processing. A systematic sequence of operations performed on data.

Note.— Examples of operations are the merging, sorting, computing or any other transformation or rearrangement with the object of extracting or revising information, or of altering the representation of information.

Decision altitude (DA) or decision height (DH). A specified altitude or height in the precision approach at which a

missed approach must be initiated if the required visual reference to continue the approach has not been established.

Note 1.— Decision altitude (DA) is referenced to mean sea level and decision height (DH) is referenced to the threshold elevation.

Note 2.— The required visual reference means that section of the visual aids or of the approach area which should have been in view for sufficient time for the pilot to have made an assessment of the aircraft position and rate of change of position, in relation to the desired flight path. In Category III operations with a decision height the required visual reference is that specified for the particular procedure and operation.

Note 3.— For convenience where both expressions are used they may be written in the form “decision altitude/height” and abbreviated “DA/H”.

Dependent parallel approaches. Simultaneous approaches to parallel or near-parallel instrument runways where radar separation minima between aircraft on adjacent extended runway centre lines are prescribed.

DETRESFA. The code word used to designate a distress phase.

Discrete code. A four-digit SSR Code with the last two digits not being “00”.

Distress phase. A situation wherein there is reasonable certainty that an aircraft and its occupants are threatened by grave and imminent danger or require immediate assistance.

D-value. The amount (positive or negative) by which the altitude (Z) of a point on an isobaric surface differs from the altitude (Zp) of the same isobaric surface in the ICAO Standard Atmosphere (i.e. D-value = Z – Zp).

Elevation. The vertical distance of a point or a level, on or affixed to the surface of the earth, measured from mean sea level.

Emergency phase. A generic term meaning, as the case may be, uncertainty phase, alert phase or distress phase.

Estimated elapsed time. The estimated time required to proceed from one significant point to another.

Estimated off-block time. The estimated time at which the aircraft will commence movement associated with departure.

Estimated time of arrival. For IFR flights, the time at which it is estimated that the aircraft will arrive over that designated point, defined by reference to navigation aids, from which it is intended that an instrument approach procedure will be commenced, or, if no navigation aid is associated with the aerodrome, the time at which the aircraft will arrive over the aerodrome. For VFR flights, the time at which it is estimated that the aircraft will arrive over the aerodrome.

Expected approach time. The time at which ATC expects that an arriving aircraft, following a delay, will leave the holding point to complete its approach for a landing.

Note.— The actual time of leaving the holding point will depend upon the approach clearance.

Filed flight plan. The flight plan as filed with an ATS unit by the pilot or a designated representative, without any subsequent changes.

Note.— When the word “message” is used as a suffix to this term, it denotes the content and format of the filed flight plan data as transmitted.

Final approach. That part of an instrument approach procedure which commences at the specified final approach fix or point, or where such a fix or point is not specified,

- a) at the end of the last procedure turn, base turn or inbound turn of a racetrack procedure, if specified; or
- b) at the point of interception of the last track specified in the approach procedure; and

ends at a point in the vicinity of an aerodrome from which:

- 1) a landing can be made; or
- 2) a missed approach procedure is initiated.

Flight crew member. A licensed crew member charged with duties essential to the operation of an aircraft during flight time.

Flight information centre. A unit established to provide flight information service and alerting service.

Flight information region. An airspace of defined dimensions within which flight information service and alerting service are provided.

Flight information service. A service provided for the purpose of giving advice and information useful for the safe and efficient conduct of flights.

Flight level. A surface of constant atmospheric pressure which is related to a specific pressure datum, 1 013.2 hectopascals (hPa), and is separated from other such surfaces by specific pressure intervals.

Note 1.— A pressure type altimeter calibrated in accordance with the Standard Atmosphere:

- a) *when set to a QNH altimeter setting, will indicate altitude;*
- b) *when set to QFE altimeter setting, will indicate height above the QFE reference datum;*
- c) *when set to a pressure of 1 013.2 hPa, may be used to indicate flight levels.*

Note 2.— The terms “height” and “altitude”, used in Note 1 above, indicate altimetric rather than geometric heights and altitudes.

Flight plan. Specified information provided to air traffic services units, relative to an intended flight or portion of a flight of an aircraft.

Note.— Specifications for flight plans are contained in Annex 2. A Model Flight Plan Form is contained in Appendix 2 to this document.

Flight status. An indication of whether a given aircraft requires special handling by air traffic services units or not.

Flight visibility. The visibility forward from the cockpit of an aircraft in flight.

Flow control. Measures designed to adjust the flow of traffic into a given airspace, along a given route, or bound for a given aerodrome, so as to ensure the most effective utilization of the airspace.

Forecast. A statement of expected meteorological conditions for a specified time or period, and for a specified area or portion of airspace.

Glide path. A descent profile determined for vertical guidance during a final approach.

Ground effect. A condition of improved performance (lift) due to the interference of the surface with the airflow pattern of the rotor system when a helicopter or other VTOL aircraft is operating near the ground.

Note.— Rotor efficiency is increased by ground effect to a height of about one rotor diameter for most helicopters.

Ground-to-air communication. One-way communication from stations or locations on the surface of the earth to aircraft.

Ground visibility. The visibility at an aerodrome, as reported by an accredited observer.

Heading. The direction in which the longitudinal axis of an aircraft is pointed, usually expressed in degrees from North (true, magnetic, compass or grid).

Height. The vertical distance of a level, a point or an object considered as a point, measured from a specified datum.

Holding point. A specified location, identified by visual or other means, in the vicinity of which the position of an aircraft in flight is maintained in accordance with air traffic control clearances.

Holding procedure. A predetermined manoeuvre which keeps an aircraft within a specified airspace while awaiting further clearance.

IFR. The symbol used to designate the instrument flight rules.

IFR flight. A flight conducted in accordance with the instrument flight rules.

IMC. The symbol used to designate instrument meteorological conditions.

INCERFA. The code word used to designate an uncertainty phase.

Independent parallel approaches. Simultaneous approaches to parallel or near-parallel instrument runways where radar separation minima between aircraft on adjacent extended runway centre lines are not prescribed.

Independent parallel departures. Simultaneous departures from parallel or near-parallel instrument runways.

Initial approach segment. That segment of an instrument approach procedure between the initial approach fix and the intermediate approach fix or, where applicable, the final approach fix or point.

Instrument approach procedure. A series of predetermined manoeuvres by reference to flight instruments with specified protection from obstacles from the initial approach fix, or where applicable, from the beginning of a defined arrival route to a point from which a landing can be completed and thereafter, if a landing is not completed, to a position at which holding or en-route obstacle clearance criteria apply.

Instrument meteorological conditions. Meteorological conditions expressed in terms of visibility, distance from cloud, and ceiling, less than the minima specified for visual meteorological conditions.

Note 1.— The specified minima for visual meteorological conditions are contained in Chapter 4 of Annex 2.

Note 2.— In a control zone, a VFR flight may proceed under instrument meteorological conditions if and as authorized by air traffic control.

Landing area. That part of a movement area intended for the landing or take-off of aircraft.

Level. A generic term relating to the vertical position of an aircraft in flight and meaning variously, height, altitude or flight level.

Location indicator. A four-letter code group formulated in accordance with rules prescribed by ICAO and assigned to the location of an aeronautical fixed station.

Manoeuvring area. That part of an aerodrome to be used for the take-off, landing and taxiing of aircraft, excluding aprons.

Meteorological information. Meteorological report, analysis, forecast, and any other statement relating to existing or expected meteorological conditions.

Meteorological office. An office designated to provide meteorological service for international air navigation.

Meteorological report. A statement of observed meteorological conditions related to a specified time and location.

Minimum fuel. The term used to describe a situation in which an aircraft's fuel supply has reached a state where little or no delay can be accepted.

Note.— This is not an emergency situation but merely indicates that an emergency situation is possible, should any undue delay occur.

Missed approach procedure. The procedure to be followed if the approach cannot be continued.

Mode (SSR). The conventional identifier related to specific functions of the interrogation signals transmitted by an SSR interrogator. There are four modes specified in Annex 10: A, C, S and intermode.

Movement area. That part of an aerodrome to be used for the take-off, landing and taxiing of aircraft, consisting of the manoeuvring area and the apron(s).

Near-parallel runways. Non-intersecting runways whose extended centre lines have an angle of convergence/divergence of 15 degrees or less.

Non-radar separation. The separation used when aircraft position information is derived from sources other than radar.

Normal operating zone (NOZ). Airspace of defined dimensions extending to either side of an ILS localizer course and/or MLS final approach track. Only the inner half of the normal operating zone is taken into account in independent parallel approaches.

NOTAM. A notice distributed by means of telecommunication containing information concerning the establishment, condition or change in any aeronautical facility, service, procedure or hazard, the timely knowledge of which is essential to personnel concerned with flight operations.

No transgression zone (NTZ). In the context of independent parallel approaches, a corridor of airspace of defined dimensions located centrally between the two extended runway centre lines, where a penetration by an aircraft requires a controller intervention to manoeuvre any threatened aircraft on the adjacent approach.

Obstacle clearance altitude (OCA) or obstacle clearance height (OCH). The lowest altitude or the lowest height above the elevation of the relevant runway threshold or the aerodrome elevation as applicable, used in establishing compliance with appropriate obstacle clearance criteria.

Note 1.— Obstacle clearance altitude is referenced to mean sea level and obstacle clearance height is referenced to the threshold elevation or in the case of non-precision

approaches to the aerodrome elevation or the threshold elevation if that is more than 2 m (7 ft) below the aerodrome elevation. An obstacle clearance height for a circling approach is referenced to the aerodrome elevation.

Note 2.— For convenience when both expressions are used they may be written in the form “obstacle clearance altitude/height” and abbreviated “OCA/H”.

Operational control. The exercise of authority over the initiation, continuation, diversion or termination of a flight in the interest of the safety of the aircraft and the regularity and efficiency of the flight.

Operator. A person, organization or enterprise engaged in or offering to engage in an aircraft operation.

Pilot-in-command. The pilot responsible for the operation and safety of the aircraft during flight time.

Precision approach radar (PAR). Primary radar equipment used to determine the position of an aircraft during final approach, in terms of lateral and vertical deviations relative to a nominal approach path, and in range relative to touchdown.

Note.— Precision approach radars are designated to enable pilots of aircraft to be given guidance by radiocommunication during the final stages of the approach to land.

Pressure-altitude. An atmospheric pressure expressed in terms of altitude which corresponds to that pressure in the Standard Atmosphere.*

Primary radar. A radar system which uses reflected radio signals.

Primary surveillance radar (PSR). A surveillance radar system which uses reflected radio signals.

Procedure turn. A manoeuvre in which a turn is made away from a designated track followed by a turn in the opposite direction to permit the aircraft to intercept and proceed along the reciprocal of the designated track.

Note 1.— Procedure turns are designated “left” or “right” according to the direction of the initial turn.

Note 2.— Procedure turns may be designated as being made either in level flight or while descending, according to the circumstances of each individual procedure.

Profile. The orthogonal projection of a flight path or portion thereof on the vertical surface containing the nominal track.

PSR blip. The visual indication, in non-symbolic form, on a radar display of the position of an aircraft obtained by primary radar.

Radar. A radio detection device which provides information on range, azimuth and/or elevation of objects.

Radar approach. An approach in which the final approach phase is executed under the direction of a radar controller.

Radar clutter. The visual indication on a radar display of unwanted signals.

Radar contact. The situation which exists when the radar position of a particular aircraft is seen and identified on a radar display.

Radar control. Term used to indicate that radar-derived information is employed directly in the provision of air traffic control service.

Radar controller. A qualified air traffic controller holding a radar rating appropriate to the functions to which he is assigned.

Radar display. An electronic display of radar-derived information depicting the position and movement of aircraft.

Radar identification. The situation which exists when the radar position of a particular aircraft is seen on a radar display and positively identified by the air traffic controller.

Radar map. Information superimposed on a radar display to provide ready indication of selected features.

Radar monitoring. The use of radar for the purpose of providing aircraft with information and advice relative to significant deviations from nominal flight path, including deviations from the terms of their air traffic control clearances.

Radar position indication (RPI). The visual indication, in non-symbolic and/or symbolic form, on a radar display of the position of an aircraft obtained by primary and/or secondary surveillance radar.

* As defined in Annex 8.

Radar position symbol (RPS). The visual indication, in symbolic form, on a radar display, of the position of an aircraft obtained after automatic processing of positional data derived from primary and/or secondary surveillance radar.

Radar separation. The separation used when aircraft position information is derived from radar sources.

Radar service. Term used to indicate a service provided directly by means of radar.

Radar track position. An extrapolation of aircraft position by the computer based upon radar information and used by the computer for tracking purposes.

Note.— In some cases, information other than radar-derived information is used to assist the tracking processes.

Radar unit. That element of an air traffic services unit which uses radar equipment to provide one or more services.

Radar vectoring. Provision of navigational guidance to aircraft in the form of specific headings, based on the use of radar.

Receiving unit/controller. Air traffic services unit/air traffic controller to which a message is sent.

Note.— See definition of “sending unit/controller”.

Repetitive flight plan (RPL). A flight plan related to a series of frequently recurring, regularly operated individual flights with identical basic features, submitted by an operator for retention and repetitive use by ATS units.

Reporting point. A specified geographical location in relation to which the position of an aircraft can be reported.

Required navigation performance (RNP). A statement of the navigation performance necessary for operation within a defined airspace.

Note.— Navigation performance and requirements are defined for a particular RNP type and/or application.

Rescue co-ordination centre. A unit responsible for promoting efficient organization of search and rescue service and for co-ordinating the conduct of search and rescue operations within a search and rescue region.

Rules of the Air and Air Traffic Services (PANS-RAC)

Rescue unit. A unit composed of trained personnel and provided with equipment suitable for the expeditious conduct of search and rescue.

RNP type. A containment value expressed as a distance in nautical miles from the intended position within which flights would be for at least 95 per cent of the total flying time.

Example.— RNP 4 represents a navigation accuracy of plus or minus 7.4 km (4 NM) on a 95 per cent containment basis.

Runway. A defined rectangular area on a land aerodrome prepared for the landing and take-off of aircraft.

Runway-holding position. A designated position intended to protect a runway, an obstacle limitation surface, or an ILS/MLS critical/sensitive area at which taxiing aircraft and vehicles shall stop and hold, unless otherwise authorized by the aerodrome control tower.

Runway visual range. The range over which the pilot of an aircraft on the centre line of a runway can see the runway surface markings or the lights delineating the runway or identifying its centre line.

Secondary radar. A radar system wherein a radio signal transmitted from the radar station initiates the transmission of a radio signal from another station.

Secondary surveillance radar (SSR). A surveillance radar system which uses transmitters/receivers (interrogators) and transponders.

Segregated parallel operations. Simultaneous operations on parallel or near-parallel instrument runways in which one runway is used exclusively for approaches and the other runway is used exclusively for departures.

Sending unit/controller. Air traffic services unit/air traffic controller transmitting a message.

Note.— See definition of “receiving unit/controller”.

Shoreline. A line following the general contour of the shore, except that in cases of inlets or bays less than 30 nautical miles in width, the line shall pass directly across the inlet or bay to intersect the general contour on the opposite side.

SIGMET information. Information issued by a meteorological watch office concerning the occurrence or expected occurrence of specified en-route weather phenomena which may affect the safety of aircraft operations.

Signal area. An area on an aerodrome used for the display of ground signals.

Significant point. A specified geographical location used in defining an ATS route or the flight path of an aircraft and for other navigation and ATS purposes.

Slush. Water-saturated snow which with a heel-and-toe slap-down motion against the ground will be displaced with a splatter; specific gravity: 0.5 up to 0.8.

Note.— Combinations of ice, snow and/or standing water may, especially when rain, rain and snow, or snow is falling, produce substances with specific gravities in excess of 0.8. These substances, due to their high water/ice content, will have a transparent rather than a cloudy appearance and, at the higher specific gravities, will be readily distinguishable from slush.

Snow (on the ground).

- a) *Dry snow.* Snow which can be blown if loose or, if compacted by hand, will fall apart upon release; specific gravity: up to but not including 0.35.
- b) *Wet snow.* Snow which, if compacted by hand, will stick together and tend to or form a snowball; specific gravity: 0.35 up to but not including 0.5.
- c) *Compacted snow.* Snow which has been compressed into a solid mass that resists further compression and will hold together or break up into lumps if picked up; specific gravity: 0.5 and over.

Special VFR flight. A VFR flight cleared by air traffic control to operate within a control zone in meteorological conditions below VMC.

SSR response. The visual indication, in non-symbolic form, on a radar display, of a response from an SSR transponder in reply to an interrogation.

Surveillance radar. Radar equipment used to determine the position of an aircraft in range and azimuth.

Taxiing. Movement of an aircraft on the surface of an aerodrome under its own power, excluding take-off and landing.

Taxiway. A defined path on a land aerodrome established for the taxiing of aircraft and intended to provide a link between one part of the aerodrome and another, including:

- a) *Aircraft stand taxiway.* A portion of an apron designated as a taxiway and intended to provide access to aircraft stands only.
- b) *Apron taxiway.* A portion of a taxiway system located on an apron and intended to provide a through taxi route across the apron.
- c) *Rapid exit taxiway.* A taxiway connected to a runway at an acute angle and designed to allow landing aeroplanes to turn off at higher speeds than are achieved on other exit taxiways thereby minimizing runway occupancy times.

Terminal control area. A control area normally established at the confluence of ATS routes in the vicinity of one or more major aerodromes.

Threshold. The beginning of that portion of the runway usable for landing.

Total estimated elapsed time. For IFR flights, the estimated time required from take-off to arrive over that designated point, defined by reference to navigation aids, from which it is intended that an instrument approach procedure will be commenced, or, if no navigation aid is associated with the destination aerodrome, to arrive over the destination aerodrome. For VFR flights, the estimated time required from take-off to arrive over the destination aerodrome.

Touchdown. The point where the nominal glide path intercepts the runway.

Note.— “Touchdown” as defined above is only a datum and is not necessarily the actual point at which the aircraft will touch the runway.

Track. The projection on the earth's surface of the path of an aircraft, the direction of which path at any point is usually expressed in degrees from North (true, magnetic or grid).

Traffic avoidance advice. Advice provided by an air traffic services unit specifying manoeuvres to assist a pilot to avoid a collision.

Traffic information. Information issued by an air traffic services unit to alert a pilot to other known or observed air traffic which may be in proximity to the position or intended route of flight and to help the pilot avoid a collision.

Transfer of control point. A defined point located along the flight path of an aircraft, at which the responsibility for providing air traffic control service to the aircraft is transferred from one control unit or control position to the next.

Transferring unit/controller. Air traffic control unit/air traffic controller in the process of transferring the responsibility for providing air traffic control service to an aircraft to the next air traffic control unit/air traffic controller along the route of flight.

Note.— See definition of “accepting unit/controller”.

Transition altitude. The altitude at or below which the vertical position of an aircraft is controlled by reference to altitudes.

Transition layer. The airspace between the transition altitude and the transition level.

Transition level. The lowest flight level available for use above the transition altitude.

Uncertainty phase. A situation wherein uncertainty exists as to the safety of an aircraft and its occupants.

Unmanned free balloon. A non-power-driven, unmanned, lighter-than-air aircraft in free flight.

Note.— Unmanned free balloons are classified as heavy, medium or light in accordance with specifications contained in Annex 2, Appendix 4.

VFR. The symbol used to designate the visual flight rules.

Rules of the Air and Air Traffic Services (PANS-RAC)

VFR flight. A flight conducted in accordance with the visual flight rules.

Visibility. The ability, as determined by atmospheric conditions and expressed in units of distance, to see and identify prominent unlighted objects by day and prominent lighted objects by night.

Visual approach. An approach by an IFR flight when either part or all of an instrument approach procedure is not completed and the approach is executed in visual reference to terrain.

Visual meteorological conditions. Meteorological conditions expressed in terms of visibility, distance from cloud, and ceiling, equal to or better than specified minima.

Note.— The specified minima are contained in Annex 2, Chapter 4.

VMC. The symbol used to designate visual meteorological conditions.

Way-point. A specified geographical location used to define an area navigation route or the flight path of an aircraft employing area navigation. Way-points are identified as either:

Fly-by way-point. A way-point which requires turn anticipation to allow tangential interception of the next segment of a route or procedure, or

Flyover way-point. A way-point at which a turn is initiated in order to join the next segment of a route or procedure.

PART II. GENERAL PROVISIONS

SCOPE OF THE RULES OF THE AIR AND AIR TRAFFIC SERVICES PROCEDURES

1. Relationship to other documents

Procedures contained in the present documents are complementary to the Standards and Recommended Practices contained in Annexes 2 and 11. They are supplemented when necessary by regional procedures contained in Part 1 of the Regional Supplementary Procedures (Doc 7030).

Note 1.— Although these procedures are mainly directed to air traffic services personnel, attention of pilots-in-command should be drawn to the following paragraphs in particular, which are of direct interest to them:

Part II: 8, 9, 10, 12.1, 13, 14, 15 and 17;
Part III: 6, 13, 16 and 17;
Part IV: 2.2, 4, 8, 9, 10.2, 10.3, 11.5 and 12;
Part V: 10.3 and 13.5;
Part VII: 1 and 2;
Part X;
Part XI and Appendices 1, 2, 4 and 5.

Note 2.— The objectives of the air traffic control service as prescribed in Annex 11 do not include prevention of collision with terrain. The procedures prescribed in this document do not therefore relieve the pilot of his responsibilities of ensuring that any clearance issued by air traffic control units are safe in this respect, except when an IFR flight is vectored by radar. See Part VI, 6.5.2.

2. Contents of the document

2.1 Part III contains the procedures applicable by air traffic control units providing area control service.

2.2 Parts III and IV contain the procedures applicable by air traffic control units providing approach control service.

2.3 Part V contains the procedures applicable by air traffic control units providing aerodrome control service.

2.3.1 The procedures for operating aeronautical ground lights have been included in Part V (Section 6) since they concern mostly aerodromes. It should be noted, however, that 6.1.1 applies to all aeronautical ground lights, whether or not they are on or in the vicinity of an aerodrome, and that the whole of Section 6 applies to all aerodromes, whether or not aerodrome control service is provided.

2.4 Part VI contains procedures applicable by air traffic services units using radar in the performance of their functions.

2.5 Part VII contains the procedures applicable by air traffic services units providing flight information service and alerting service.

2.6 Part VIII contains procedures regarding the co-ordination to be effected between air traffic services units, between control positions within such units, and between such units and associated aeronautical telecommunication stations.

2.7 Part IX deals with air traffic services messages which are necessary for the effective operation of air traffic services.

2.8 Part X contains typical phraseologies to be used in the provision of air traffic services, arranged in groups to relate to the particular phase of air traffic services with which they are generally employed.

2.9 Part XI contains procedures concerning controller-pilot data link communications (CPDLC). The associated CPDLC message set is contained in Appendix 5.

ALLOCATION OF RESPONSIBILITY IN THE PROVISION OF AIR TRAFFIC SERVICES

3. Responsibility for the provision of air traffic control service

3.1 Area control service shall be provided:

- a) by an area control centre; or
- b) by the unit providing approach control service in a control zone or in a control area of limited extent

which is designated primarily for the provision of approach control service, when no area control centre is established.

3.2 Approach control service shall be provided:

- a) by an aerodrome control tower or an area control centre, when it is necessary or desirable to combine under the responsibility of one unit the functions of the approach control service and those of the aerodrome control service or the area control service; or
- b) by an approach control office, when it is necessary or desirable to establish a separate unit.

3.3 Aerodrome control service shall be provided by an aerodrome control tower.

4. Responsibility for the provision of flight information service and alerting service

4.1 Flight information service and alerting service shall be provided as follows:

- a) *within a flight information region*: by a flight information centre, unless the responsibility for providing such services is assigned to an air traffic control unit having adequate facilities for the exercise of such responsibilities;
- b) *within controlled airspace and at controlled aerodromes*: by the relevant air traffic control units.

5. Division of responsibility for control between air traffic control units

5.1 Between a unit providing aerodrome control service and a unit providing approach control service

5.1.1 Except for flights which are provided aerodrome control service only, the control of arriving and departing controlled flights shall be divided between units providing aerodrome control service and units providing approach control service as follows:

Rules of the Air and Air Traffic Services (PANS-RAC)

5.1.1.1 *Arriving aircraft*. The responsibility for the control of an aircraft approaching to land shall be transferred from the unit providing approach control service to the unit providing aerodrome control service when the aircraft:

- a) is in the vicinity of the aerodrome, and
 - i) it is considered that approach and landing will be completed in visual reference to the ground, or
 - ii) it has reached uninterrupted visual meteorological conditions, or
- b) has landed,

whichever is the earlier.

Note.— Even though there is an approach control office, control of certain flights may be transferred directly from an area control centre to an aerodrome control tower and vice versa, by prior arrangement between the units concerned for the relevant part of approach control service to be provided by the area control centre or the aerodrome control tower, as applicable.

5.1.1.2 *Departing aircraft*. The responsibility for control of a departing aircraft shall be transferred from the unit providing aerodrome control service to the unit providing approach control service:

- a) *when visual meteorological conditions prevail in the vicinity of the aerodrome*:
 - i) prior to the time the aircraft leaves the vicinity of the aerodrome, or
 - ii) prior to the aircraft entering instrument meteorological conditions,

whichever is the earlier;

- b) *when instrument meteorological conditions prevail at the aerodrome*:
 - i) immediately before the aircraft enters the runway-in-use for take-off, or
 - ii) immediately after the aircraft is airborne, if local procedures render such action preferable.

Note.— See Note following 5.1.1.1.

5.2 Between a unit providing approach control service and a unit providing area control service

5.2.1 When area control service and approach control service are not provided by the same air traffic control unit, responsibility for controlled flights shall rest with the unit providing area control service except that a unit providing approach control service shall be responsible for the control of:

- a) arriving aircraft that have been released to it by the area control centre;
- b) departing aircraft until such aircraft are released to the area control centre.

5.2.1.1 Under approach sequence conditions the unit providing area control service shall normally be responsible for clearing aircraft to the holding point, and for including holding instructions and expected approach time in such clearances.

5.2.1.2 A unit providing approach control service shall assume control of arriving aircraft, provided such aircraft have been released to it, upon arrival of the aircraft at the point agreed for transfer of control, and shall maintain control during approach to the aerodrome.

5.2.1.3 The control of more than one approach sequence may be effected by a unit providing approach control service, provided the division of control between the unit providing area control service and the unit providing approach control service is defined in instructions approved by the appropriate ATS authority and is basically consistent with the foregoing procedures.

6. Responsibility in regard to military traffic

6.1 It is recognized that some military aeronautical operations necessitate non-compliance with certain air traffic procedures. In order to ensure the safety of flight operations the appropriate military authorities shall be asked, whenever practicable, to notify the proper air traffic control unit prior to undertaking such manoeuvres.

6.2 A reduction of separation minima required by military necessity or other extraordinary circumstances shall only be accepted by an air traffic control unit when a specific

request in some recorded form has been obtained from the authority having jurisdiction over the aircraft concerned and the lower minima then to be observed shall apply only between those aircraft. Some recorded form of instruction fully covering this reduction of separation minima must be issued by the air traffic control unit concerned.

6.3 Temporary airspace reservation, either stationary or mobile, may be established for the use of large formation flights or other military air operations. Arrangements for the reservation of such airspace shall be accomplished by co-ordination between the user and the appropriate ATS authority. The co-ordination shall be effected in accordance with the provisions of Annex 11 and completed early enough to permit timely promulgation of information in accordance with the provisions of Annex 15.

7. Responsibility in regard to unmanned free balloons

7.1 On receipt of notification of the intended flight of a medium or heavy unmanned free balloon, the air traffic services unit shall arrange for the information to be disseminated to all concerned. The information shall include:

- a) the balloon flight identification or project code name;
- b) balloon classification and description;
- c) SSR Code or NDB frequency as applicable;
- d) the launch site;
- e) the estimated time of the commencement of the launch or the planned period of the launches;
- f) the expected direction of ascent;
- g) the cruising level(s) (pressure-altitude); and
- h) the estimated elapsed time to pass 18 000 m (60 000 ft) pressure-altitude, or to reach cruising level if at or below 18 000 m (60 000 ft), together with the estimated location.

7.2 On receipt of notification that a medium or heavy unmanned free balloon has been launched, the air traffic services unit shall arrange for the information to be disseminated to all concerned. The information shall include:

- a) the balloon flight identification or project code name;

- b) balloon classification and description;
- c) SSR Code or NDB frequency as applicable;
- d) the launch site;
- e) the time of launch(es);
- f) the estimated time at which 18 000 m (60 000 ft) pressure-altitude will be passed, or the estimated time at which the cruising level will be reached if at or below 18 000 m (60 000 ft), and the estimated location;
- g) the estimated date and time of termination of the flight; and
- h) the planned location of ground contact, when applicable.

7.3 When there is reasonable expectation that a heavy or medium unmanned free balloon will cross international borders, the appropriate ATS unit shall arrange for the pre-launch and the launch notifications to be sent to the ATS unit(s) in the State(s) concerned by NOTAM Class 1. If agreed between the States concerned, the launch notification may be transmitted orally by direct ATS speech circuit between the area control centres/flight information centres involved.

7.4 Air traffic services units shall maintain radar surveillance of medium and heavy unmanned free balloons to the extent possible and, if necessary and on the request of the pilot of an aircraft, provide radar separation between the aircraft and such balloons which are radar identified or their exact position is known.

GENERAL AIR TRAFFIC SERVICES OPERATING PRACTICES

8. Flight plan

8.1 Flight plan form

8.1.1 A flight plan form based on the model in Appendix 2 should be provided for and should be used by operators and air traffic services units for the purpose of completing flight plans.

Rules of the Air and Air Traffic Services (PANS-RAC)

Note.— A different form may be provided for use in completing repetitive flight plan listings.

8.1.2 The flight plan form should be printed and should include an English text in addition to the language(s) of the State concerned.

Note.— The Model Flight Plan Form in Appendix 2 is printed in English and one other of the languages of the Organization for illustration purposes.

8.1.3 Operators and air traffic services units should comply with the instructions for completion of a flight plan form and a repetitive flight plan listing form given in Appendix 2.

Note.— The instructions for completing a flight plan form given in Appendix 2 may be conveniently printed on the inside cover of flight plan form pads, or posted in briefing rooms.

8.1.4 An operator unable to satisfy a prescribed route or area RNP should, prior to departure, advise ATC of the RNP types the aircraft is certified to meet.

8.2 Submission of a flight plan

8.2.1 *Prior to departure*

8.2.1.1 Except when other arrangements have been made for submission of repetitive flight plans, a flight plan submitted prior to departure should be submitted to the air traffic services reporting office at the departure aerodrome. If no such unit exists at the departure aerodrome, the flight plan should be submitted to the unit serving or designated to serve the departure aerodrome.

8.2.1.2 In the event of a delay of thirty (30) minutes in excess of the estimated off-block time for a controlled flight or a delay of one hour for an uncontrolled flight for which a flight plan has been submitted, the flight plan should be amended or a new flight plan submitted and the old flight plan cancelled, whichever is applicable.

8.2.2 *During flight*

8.2.2.1 A flight plan to be submitted during flight should normally be transmitted to the aeronautical telecom-

munication station serving the air traffic services unit in charge of the flight information region, control area, advisory area or advisory route in or on which the aircraft is flying, or in or through which the aircraft wishes to fly. When this is not practicable, it should be transmitted to another aeronautical telecommunication station for retransmission as required to the appropriate air traffic services unit.

Note.— If the flight plan is submitted for the purpose of obtaining air traffic control service, the aircraft is required to wait for an air traffic control clearance prior to proceeding under the conditions requiring compliance with air traffic control procedures. If the flight plan is submitted for the purpose of obtaining air traffic advisory service, the aircraft is required to wait for acknowledgement of receipt by the unit providing the service.

8.3 Acceptance of a flight plan

8.3.1 The first air traffic services unit receiving a flight plan, or change thereto, shall

- a) check it for compliance with the format and data conventions;
- b) check it for completeness and, to the extent possible, for accuracy;
- c) take action, if necessary, to make it acceptable to the air traffic services; and
- d) indicate acceptance of the flight plan or change thereto, to the originator.

8.4 Use of repetitive flight plans (RPLs)

8.4.1 General

8.4.1.1 RPLs shall not be used for flights other than IFR flights operated regularly on the same day(s) of consecutive weeks and on at least ten occasions or every day over a period of at least ten consecutive days. The elements of each flight plan shall have a high degree of stability.

Note.— For permissible incidental changes to RPL data affecting the operation for one particular day, and not intended to be a modification of the listed RPL, see 8.4.4.2.2 and 8.4.4.2.3 below.

8.4.1.2 RPLs shall cover the entire flight from the departure aerodrome to the destination aerodrome. RPL

procedures shall be applied only when all ATS authorities concerned with the flights have agreed to accept RPLs.

8.4.1.3 The use by States of RPLs for international flight shall be subject to the provision that the affected adjacent States either already use RPLs or will use them at the same time. The procedures for use between States shall be the subject of bilateral, multilateral or regional air navigation agreement as appropriate.

8.4.2 Procedures for submission of RPLs by operators

8.4.2.1 Conditions governing submission, notification of changes, or cancellation of RPLs shall be the subject of appropriate arrangements between operators and the ATS authority concerned or of regional air navigation agreements.

8.4.2.2 An RPL shall comprise information regarding such of the following items as are considered relevant by the appropriate ATS authority:

- validity period of the flight plan
- days of operation
- aircraft identification
- aircraft type and wake turbulence category
- MLS capability
- departure aerodrome
- off-block time
- cruising speed(s)
- cruising level(s)
- route to be followed
- destination aerodrome
- total estimated elapsed time
- indication of the location where the following information may be obtained immediately upon request:
 - alternate aerodromes
 - fuel endurance
 - total number of persons on board
 - emergency equipment
 - other information.

8.4.3 Submission of total listings

8.4.3.1 RPLs shall be submitted in the form of listings containing the required flight plan data using an RPL listing form specially designed for the purpose or by means of other media suitable for electronic data processing. The method of submission shall be determined by local or regional agreement.

Note.— A model RPL listing form is contained in Appendix 2.

8.4.3.2 Initial submission of complete RPL listings and any subsequent seasonal resubmission of complete listings shall be made in sufficient time to permit the data to be properly assimilated by the ATS organization. The minimum lead time required for the submission of such listings shall be established by the administrations concerned and published in their AIPs. This minimum lead time shall be at least two weeks.

8.4.3.3 Operators shall submit listings to the designated agency for distribution to the appropriate air traffic services units.

8.4.3.4 The information normally to be provided shall be that listed in 8.4.2.2 except that administrations may also require the provision of estimate information of flight information region boundaries and the primary alternate aerodrome. If so required, such information shall be provided as indicated on a repetitive flight plan listing form specially designed for the purpose.

8.4.3.5 Information regarding alternate aerodrome(s) and supplementary flight plan data (information normally provided under Item 19 of the ICAO flight plan form) shall be kept readily available by the operator at the departure aerodrome or another agreed location, so that, on request by ATS units, it can be supplied without delay. The name of the office from which the information can be obtained shall be recorded on the RPL listing form.

8.4.3.6 Acknowledgement of receipt of listings of flight plan data and/or amendment thereto shall not be required except by agreement between operators and the appropriate agency.

8.4.4 *Changes to RPL listings*

8.4.4.1 *Changes of a permanent nature*

8.4.4.1.1 Changes of a permanent nature involving the inclusion of new flights and the deletion or modification of currently listed flights shall be submitted in the form of amendment listings. These listings shall reach the air traffic services agency concerned at least seven days prior to the change becoming effective.

8.4.4.1.2 Where RPL listings have been initially submitted by the use of media suitable for electronic data processing, it shall be permissible by mutual agreement

Rules of the Air and Air Traffic Services (PANS-RAC)

between the operator and the appropriate authority for some changes to be submitted by means of RPL listing forms.

8.4.4.1.3 All RPL changes shall be submitted in accordance with the instructions for preparation of RPL listings.

8.4.4.2 *Changes of a temporary nature*

8.4.4.2.1 Changes of a temporary, non-recurring nature relating to RPLs concerning aircraft type and wake turbulence category, speed and/or cruising level shall be notified for each individual flight as early as possible and not later than 30 minutes before departure to the ATS reporting office responsible for the departure aerodrome. A change of cruising level only may be notified by radiotelephony on initial contact with the ATS unit.

8.4.4.2.2 In case of an incidental change in the aircraft identification, the departure aerodrome, the route and/or the destination aerodrome, the RPL shall be cancelled for the day concerned and an individual flight plan shall be submitted.

8.4.4.2.3 Whenever it is expected by the operator that a specific flight, for which an RPL has been submitted, is likely to encounter a delay of 30 minutes or more in excess of the off-block time stated in that flight plan, the ATS unit responsible for the departure aerodrome shall be notified immediately.

Note.— Because of the stringent requirements of flow control, failure by operators to comply with this procedure may result in the automatic cancellation of the RPL for that specific flight at one or more of the ATS units concerned.

8.4.4.2.4 Whenever it is known to the operator that any flight, for which an RPL has been submitted, is cancelled, the ATS unit responsible for the departure aerodrome shall be notified.

8.4.4.3 *Operator/pilot liaison*

8.4.4.3.1 The operator shall ensure that the latest flight plan information, including permanent and incidental changes, pertaining to a particular flight and duly notified to the appropriate agency, is made available to the pilot-in-command.

8.4.5 *RPL procedures for ATS units*

8.4.5.1 The procedures for handling RPLs described herein are applicable regardless of whether automatic data

processing equipment is utilized or whether flight plan data is handled manually.

8.4.5.2 Implementation of RPL procedures

8.4.5.2.1 Procedures for use of RPLs may be established for flights operating within a single flight information region or a single State.

8.4.5.2.2 Procedures may also be established for flights across international boundaries subject to the provision that affected States currently utilize or will concurrently use RPLs.

8.4.5.2.2.1 Application of RPL procedures for international flights requires the establishment of bilateral or multilateral agreements between the States concerned. Multilateral agreements involving a number of States may take the form of regional air navigation agreements.

8.4.5.2.3 Application of RPLs requires agreements with participating operators to establish submission and amendment procedures.

8.4.5.2.4 Agreements shall include provisions for the following procedures:

- 1) initial submission;
- 2) permanent changes;
- 3) temporary and incidental changes;
- 4) cancellations;
- 5) additions; and
- 6) completely revised listings when indicated by extensive changes.

8.4.5.3 Collection, storage and processing of RPL data

8.4.5.3.1 Any State using RPLs shall designate one or more agencies responsible for administering such data. The area of responsibility for any such designated agency shall be at least one flight information region. However, part or the entire area of responsibility of one or more States may be administered jointly by a designated agency. Each designated agency shall distribute relevant RPL data to the ATS units concerned within its area of responsibility so that such data reach these units in sufficient time to become effective.

8.4.5.3.2 RPLs shall be stored by each ATS unit concerned in a manner that will ensure that they are

systematically activated on the appropriate day of operation in the order of estimated times indicative of entry into the unit's area of responsibility. Activation shall be accomplished in sufficient time to present the data to the controller in appropriate form for his analysis and control action.

8.4.5.4 Suspension of RPL procedures

8.4.5.4.1 An appropriate ATS authority obliged, due to exceptional circumstances, to temporarily suspend the use of RPLs in its area of responsibility or a specified part thereof, shall publish notice of such suspension with as much advance notice as possible and in the most suitable form considering the circumstances.

8.4.5.5 ATS messages related to individual flights operating on an RPL

8.4.5.5.1 ATS messages relating to individual flights operating on an RPL shall be originated and addressed to ATS units concerned in a manner identical to that used for flights operating on individual flight plans.

9. Change from IFR to VFR flight

9.1 Change from IFR flight to VFR flight is only acceptable when a message initiated by the pilot-in-command containing the specific expression "CANCELLING MY IFR FLIGHT", together with the changes, if any, to be made to his current flight plan, is received by an air traffic services unit. No invitation to change from IFR flight to VFR flight is to be made either directly or by inference.

9.2 No reply, other than the acknowledgement "IFR FLIGHT CANCELLED AT ... (time)", should normally be made by an air traffic services unit.

9.3 When an air traffic services unit is in possession of information that instrument meteorological conditions are likely to be encountered along the route of flight, a pilot changing from IFR flight to VFR flight should, if practicable, be so advised.

Note.— See Part IX, 4.3.2.1.

9.4 An air traffic services unit receiving notification of an aircraft's intention to change from IFR to VFR flight shall, as soon as practicable thereafter, so inform all other air traffic services units to whom the IFR flight plan was addressed, except those units through whose regions or areas the flight has already passed.

10. Clearances and information

10.1 Scope

10.1.1 The issuance of air traffic control clearances by air traffic control units constitutes authority for an aircraft to proceed only in so far as known air traffic is concerned.

10.1.2 Clearances are based solely on expediting and separating air traffic and do not constitute authority to violate any applicable regulations for promoting the safety of flight operations or for any other purpose.

10.1.3 Clearances are based on known traffic conditions which affect safety in aircraft operation. Such traffic conditions include not only aircraft in the air and on the manoeuvring area over which control is being exercised, but also any vehicular traffic or other obstructions not permanently installed on the manoeuvring area in use.

10.1.4 If an air traffic control clearance is not suitable to the pilot-in-command of an aircraft, he may request and, if practicable, obtain an amended clearance.

10.1.5 Clearances issued by controllers relate to traffic and aerodrome conditions only and do not relieve a pilot of any responsibility whatsoever in connexion with a possible violation of applicable rules and regulations.

10.2 Issuance

10.2.1 Air traffic control units shall issue such air traffic control clearances as are necessary to meet the objectives of collision prevention and the expedition and maintenance of an orderly flow of air traffic.

10.2.2 Aircraft flying through a terminal control area shall, where possible, be cleared by the most direct route from the entry to the exit point of the terminal control area. Similarly, aircraft arriving and/or departing within a terminal control area shall, where possible, be cleared by the most direct route from the point of entry to the aerodrome of landing or from the aerodrome of departure to the point of exit.

10.2.3 Aircraft intending supersonic flight shall, whenever practicable, be cleared for the transonic acceleration phase prior to departure.

11. Control of air traffic flow

11.1 When it becomes apparent to an air traffic control unit that traffic additional to that already accepted cannot be accommodated within a given period of time at a particular location or in a particular area, or can only be accommodated at a given rate, that unit shall so advise other air traffic control units known or believed to be concerned. Pilots-in-command of aircraft destined to the location or area in question and operators known or believed to be concerned shall also be advised of the delays expected or the restrictions that will be applied.

Note.— Attention is drawn to the guidance material contained in the Air Traffic Services Planning Manual (Doc 9426) regarding flow control.

12. Altimeter setting procedures

12.1 Expression of vertical position of aircraft

12.1.1 For flights in the vicinity of aerodromes the vertical position of aircraft shall, except as provided for in 12.1.1.1 and 12.1.1.2, be expressed in terms of altitudes at or below the transition altitude and in terms of flight levels at or above the transition level. While passing through the transition layer, vertical position shall be expressed in terms of flight levels when ascending and in terms of altitudes when descending.

12.1.1.1 After approach clearance has been issued and the descent to land is commenced, the vertical position of an aircraft above the transition level may be expressed by reference to altitudes (QNH) provided that level flight above the transition altitude is not indicated or anticipated.

Note.— This is intended to apply primarily to turbine-engined aircraft for which an uninterrupted descent from a high level is desirable and to aerodromes equipped to control such aircraft by reference to altitudes throughout the descent.

12.1.1.2 When an aircraft which has been given a clearance as number one to land is completing its approach using QFE, the vertical position of the aircraft shall be expressed in terms of height above aerodrome elevation during that portion of its flight for which QFE may be used, except that it shall be expressed in terms of height above runway threshold elevation:

- a) for instrument runways, if the threshold is 2 metres (7 feet) or more below the aerodrome elevation, and
- b) for precision approach runways.

12.1.2 For flights en route the vertical position of aircraft shall be expressed in terms of:

- a) flight levels at or above the lowest usable flight level;
- b) altitudes below the lowest usable flight level;

except where, on the basis of regional air navigation agreements, a transition altitude has been established for a specified area, in which case the provisions of 12.1.1 shall apply.

12.2 Determination of the transition level

12.2.1 Approach control offices or aerodrome control towers shall establish the transition level to be used in the vicinity of the relevant aerodrome(s) for the appropriate period of time on the basis of QNH reports and forecast mean sea level pressure if required.

12.2.2 The transition level shall be the lowest flight level available for use above the transition altitude established for the aerodrome(s) concerned. Where a common transition altitude has been established for two or more aerodromes which are so closely located as to require co-ordinated procedures, the appropriate air traffic services units shall establish a common transition level to be used at any given time in the vicinity of the aerodrome concerned.

Note.— See Part III, 4.2, regarding the determination of the lowest usable flight level(s) for control areas.

12.3 Provision of information

12.3.1 Appropriate air traffic services units shall at all times have available for transmission to aircraft in flight, on request, the information required to determine the lowest flight level which will ensure adequate terrain clearance on routes or segments of routes for which this information is required.

Note.— If so prescribed on the basis of regional air navigation agreements, this information may consist of climatological data.

12.3.2 Flight information centres and area control centres shall have available for transmission to aircraft on request an appropriate number of QNH reports or forecast pressures for the flight information regions and control areas for which they are responsible.

12.3.3 The transition level shall be included in approach clearances when so prescribed by the appropriate authority or requested by the pilot.

12.3.4 A QNH altimeter setting shall be included in approach clearances or clearances to enter the traffic circuit and in taxi clearances for departing aircraft, except when it is known that the aircraft already have received the information.

12.3.5 A QFE altimeter setting shall be provided to aircraft on request or on a regular basis in accordance with local arrangements; it shall be the QFE for the aerodrome elevation except for:

- a) non-precision approach runways, if the threshold is 2 metres (7 feet) or more below the aerodrome elevation, and
- b) precision approach runways,

in which cases the QFE for the relevant runway threshold shall be provided.

12.3.6 Altimeter settings provided to aircraft shall be rounded down to the nearest lower whole hectopascal.

13. Indication of heavy wake turbulence category and MLS capability

13.1 For aircraft in the heavy wake turbulence category the word “Heavy” shall be included immediately after the aircraft call sign in the initial radiotelephony contact between such aircraft and the aerodrome control tower or the approach control office prior to departure or arrival.

Note 1.— Wake turbulence categories are specified in the instructions for completing Item 9 of the flight plan in Appendix 2.

Note 2.— Until flight data processing systems can process designators which will fully delineate MLS capability, radiotelephony contact may be required to convey to ATC the MLS capability of an individual aircraft on a particular flight.

13.2 The appropriate MLS capability designator shall be included, whenever appropriate, in the initial radiotelephony contact between such aircraft and the aerodrome control tower, or the approach control office, prior to departure or arrival.

Note.— Designators for MLS capabilities are specified in the instructions for completing Item 10 of the flight plan in Appendix 2.

14. Position reporting

14.1 Transmission of position reports

14.1.1 On routes defined by designated significant points, position reports shall be made when over, or as soon as possible after passing, each designated compulsory reporting point, except as provided in 14.1.3. Additional reports over other points may be requested by the appropriate air traffic services unit when so required for air traffic services purposes.

14.1.2 On routes not defined by designated significant points, position reports shall be made as soon as possible after the first half hour of flight and at hourly intervals thereafter, except as provided in 14.1.3. Additional reports at shorter intervals of time may be requested by the appropriate air traffic services unit when so required for air traffic services purposes.

14.1.3 Under conditions specified by the appropriate ATS authority, flights may be exempted from the requirement to make position reports at each designated compulsory reporting point or interval. In applying this paragraph, account should be taken of the meteorological requirement for the making and reporting of routine aircraft observations.

Note.— This is intended to apply in cases where adequate flight progress data are available from other sources, e.g. ground radar (see Part VI, 6.4.4), and in other circumstances where the omission of routine reports from selected flights is found to be acceptable.

14.1.4 The position reports required by 14.1.1 and 14.1.2 shall be made to the air traffic services unit serving the airspace in which the aircraft is operated. In addition, when so prescribed by the appropriate ATS authority in aeronaut-

Rules of the Air and Air Traffic Services (PANS-RAC)

ical information publications or requested by the appropriate air traffic services unit, the last position report before passing from one flight information region or control area to an adjacent flight information region or control area shall be made to the air traffic services unit serving the airspace about to be entered.

14.1.5 If a position report is not received at the expected time, subsequent control shall not be based on the assumption that the estimated time is accurate. Immediate action shall be taken to obtain the report if it is likely to have any bearing on the control of other aircraft.

14.2 Contents of position reports

14.2.1 The position reports required by 14.1.1 and 14.1.2 shall contain the following elements of information, except that elements (4), (5) and (6) may be omitted from position reports transmitted by radiotelephony, when so prescribed on the basis of regional air navigation agreements:

- 1) Aircraft identification
- 2) Position
- 3) Time
- 4) Flight level or altitude
- 5) Next position and time over
- 6) Ensuing significant point.

Note.— Omission of element (4) may be possible when flight level or altitude, as appropriate, derived from SSR Mode C information can be made continuously available to controllers in a labelled form, and when adequate procedures have been developed to guarantee the safe and efficient use of SSR Mode C information.

14.3 Transmission of ADS reports

14.3.1 The position reports shall be made automatically to the air traffic services unit serving the airspace in which the aircraft is operating. The requirements for the transmission and contents of ADS reports shall be established by the controlling ATC unit on the basis of current operational conditions, and communicated to the aircraft and acknowledged through an ADS agreement.

14.4 Contents of ADS reports

14.4.1 ADS reports shall be composed of data blocks selected from the following:

- a) Basic ADS
 - Latitude
 - Longitude
 - Altitude
 - Time
 - Figure of merit
- b) Ground vector
 - Track
 - Ground speed
 - Rate of climb or descent
- c) Air vector
 - Heading
 - Mach or IAS
 - Rate of climb or descent
- d) Projected profile
 - Next way-point
 - Estimated altitude at next way-point
 - Estimated time at next way-point (Next + 1) way-point
 - Estimated altitude at (next + 1) way-point
 - Estimated time at (next + 1) way-point
- e) Meteorological information
 - Wind speed
 - Wind direction
 - Temperature
 - Turbulence (if available)
 - Humidity (if available)
- f) Short-term intent
 - Latitude at projected intent point
 - Longitude at projected intent point
 - Altitude at projected intent point
 - Time of projection

If an altitude, track or speed change is predicted to occur between the aircraft's current position and the projected intent point, additional information would be provided in an intermediate intent block as follows:

- Distance from current point to change point
- Track from current point to change point
- Altitude at change point
- Predicted time to change point

- g) Extended projected profile (in response to an interrogation from the ground system)

- Next way-point
- Estimated altitude at next way-point
- Estimated time at next way-point (Next + 1) way-point
- Estimated altitude at (next + 1) way-point
- Estimated time at (next + 1) way-point (Next + 2) way-point
- Estimated altitude at (next + 2) way-point
- Estimated time at (next + 2) way-point [repeated for up to (next + 128) way-points]

14.4.2 The basic ADS data block shall be required from all ADS-equipped aircraft. Remaining ADS data blocks shall be included as necessary. In addition to any requirements concerning its transmission for ATS purposes, data block e) (Meteorological information) shall be transmitted in accordance with Annex 3, 5.4.1.

14.4.3 In addition to the above data blocks, other information shall be transmitted, including a block identifier, aircraft identification and 24-bit aircraft address.

15. Reporting of operational and meteorological information

15.1 When operational and/or routine meteorological information is to be reported by an aircraft en route at points or times where position reports are required in accordance with 14.1.1 and 14.1.2, the position report shall be given in the form of a routine air-report. Special aircraft observations shall be reported as special air-reports. All air-reports shall be reported as soon as is practicable.

15.2 When ADS is being applied, routine air-reports shall be made in accordance with 14.4.2.

15.3 Contents of routine air-reports

15.3.1 Routine air-reports transmitted by voice or data link, when ADS is not being applied, shall give information relating to such of the following elements as are necessary for compliance with 15.3.2:

Section 1.— Position information:

- 1) Aircraft identification
- 2) Position
- 3) Time
- 4) Flight level or altitude

- 5) Next position and time over
- 6) Ensuing significant point

Section 2.— Operational information:

- 7) Estimated time of arrival
- 8) Endurance

Section 3.— Meteorological information:

- 9) Air temperature
- 10) Wind direction
- 11) Wind speed
- 12) Turbulence
- 13) Aircraft icing
- 14) Humidity (if available).

15.3.2 Section 1 of the air-report is obligatory, except that elements (5) and (6) thereof may be omitted when so prescribed on the basis of regional air navigation agreements. Section 2 of the air-report, or a portion thereof, shall only be transmitted when so requested by the operator or a designated representative, or when deemed necessary by the pilot-in-command. Section 3 of the air-report shall be transmitted in accordance with Annex 3, 5.4.2.

Note.— While element (4), flight level or altitude, may, in accordance with Part II, 14.2.1, be omitted from the contents of a position report transmitted by radiotelephony when so prescribed on the basis of regional air navigation agreements, that element may not be omitted from Section 1 of an air-report.

15.4 Contents of special air-reports

15.4.1 Special air-reports shall be made by all aircraft whenever the following conditions are encountered or observed:

- a) severe turbulence; or
- b) severe icing; or
- c) severe mountain wave; or
- d) thunderstorms, without hail that are obscured, embedded, widespread or in squall-lines; or
- e) thunderstorms, with hail that are obscured, embedded, widespread or in squall-lines; or
- f) heavy duststorm or heavy sandstorm; or

Rules of the Air and Air Traffic Services (PANS-RAC)

- g) volcanic ash cloud; or
- h) pre-eruption volcanic activity or a volcanic eruption.

Note.— Pre-eruption volcanic activity in this context means unusual and/or increasing volcanic activity which could presage a volcanic eruption.

In addition, in the case of transonic and supersonic flight:

- i) moderate turbulence; or
- j) hail; or
- k) cumulonimbus clouds.

15.4.2 When air-ground data link is used, special air-reports shall contain the following elements:

Message type designator
Aircraft identification

Data block 1:

Latitude
Longitude
Pressure-altitude
Time

Data block 2:

Wind direction
Wind speed
Temperature
Turbulence (if available)
Humidity (if available)

Data block 3:

Condition prompting the issuance of the special air-report; to be selected from the list a) to k) presented under 15.4.1 above.

15.4.3 When voice communications are used, special air-reports shall contain the following elements:

Message type designator

Section 1.— Position information

- 1) Aircraft identification
- 2) Position

- 3) Time
- 4) Flight level or altitude

Section 3.— Meteorological information

- 5) Condition prompting the issuance of the special air-report, to be selected from the list a) to k) presented under 15.4.1 above.

15.5 Compilation and transmission of air-reports by voice communications

15.5.1 Forms based on the model AIREP/AIREP SPECIAL form at Appendix 1 shall be provided for the use of flight crew in compiling the reports. The detailed instructions for reporting as given at Appendix 1, shall be complied with.

15.5.2 The detailed instructions, including the formats of messages and the phraseologies given at Appendix 1 shall be used by flight crew when transmitting air-reports and by air traffic services units when re-transmitting such reports.

Note.— Increasing use of air-reports in automated systems makes it essential that the elements of such reports be transmitted in the order and form prescribed.

15.6 Recording of special air-reports of volcanic activity

15.6.1 Special air-reports containing observations of volcanic activity shall be recorded on the special air-report of volcanic activity form. Forms based on the model form for special air-reports of volcanic activity at Appendix 1 shall be provided for flight crews operating on routes which could be affected by volcanic ash clouds.

Note.— The recording and reporting instructions may conveniently be printed on the back of the special air-report of volcanic activity form.

16. Forwarding of meteorological information

16.1 When receiving ADS reports which contain a meteorological information block, air traffic services units shall relay the basic ADS and meteorological information blocks without delay to the world area forecast centres (WAFCs) and, as appropriate, to regional area forecast centres (RAFCs).

16.2 When receiving special air-reports by data link communications, air traffic services units shall forward them without delay to their associated meteorological watch office, the WAFCs and, as appropriate, to RAFCs.

16.3 When receiving air-reports by voice communications, air traffic services units shall forward them without delay to their associated meteorological watch offices. In the case of routine air-reports which contain a Section 3, the air traffic services unit shall forward Section 1, sub-items 1 to 3 and Section 3.

17. Air traffic incident report

17.1 An air traffic incident report should be submitted, normally to the air traffic services unit concerned, for incidents specifically related to the provision of air traffic services involving such occurrences as aircraft proximity (AIRPROX) or other serious difficulty resulting in a hazard to aircraft, caused by, e.g.: faulty procedures, non-compliance with procedures, or failure of ground facilities.

17.2 Procedures should be established for the reporting of aircraft proximity incidents and their investigation to promote the safety of aircraft. The degree of risk involved in an aircraft proximity should be determined in the incident investigation and classified as “risk of collision”, “safety not assured”, “no risk of collision” or “risk not determined”.

17.3 When an accident/incident investigative authority conducts an investigation of an aircraft proximity incident, the air traffic services aspects should be included.

Note.— A model air traffic incident report form together with instructions for its completion is at Appendix 4. Further information regarding air traffic incidents is contained in the Air Traffic Services Planning Manual (Doc 9426).

18. Change of radiotelephony call sign for aircraft

18.1 An ATC unit may instruct an aircraft to change its type of radiotelephony (RTF) call sign, in the interests of safety, when similarity between two or more aircraft RTF call signs are such that confusion is likely to occur.

18.1.1 Any such change to the type of call sign shall be temporary and shall be applicable only within the airspace(s) where the confusion is likely to occur.

18.1.2 To avoid confusion, the ATC unit should, if appropriate, identify the aircraft which will be instructed to change its call sign by referring to its position and/or level.

18.1.3 When an ATC unit changes the type of call sign of an aircraft, that unit shall ensure that the aircraft reverts to the call sign indicated by the flight plan when the aircraft is transferred to another ATC unit, except when the call sign change has been co-ordinated between the two ATC units concerned.

18.1.4 The appropriate ATC unit shall advise the aircraft concerned when it is to revert to the call sign indicated by the flight plan.

**19. Procedures in regard to aircraft
equipped with airborne collision
avoidance systems (ACAS)**

19.1 The procedures to be applied for the provision of air traffic services to aircraft equipped with ACAS shall be identical to those applicable to non-ACAS equipped aircraft.

Rules of the Air and Air Traffic Services (PANS-RAC)

In particular, the prevention of collisions, the establishment of appropriate separation and the information which might be provided in relation to conflicting traffic and to possible avoiding action shall conform with the normal ATS procedures and shall exclude consideration of aircraft capabilities dependent on ACAS equipment.

19.2 When a pilot reports a manoeuvre induced by an ACAS resolution advisory, the controller shall not attempt to modify the aircraft flight path until the pilot reports returning to the terms of the current air traffic control instruction or clearance but shall provide traffic information as appropriate.

Note 1.— The ACAS capability of an aircraft will not normally be known to air traffic controllers.

Note 2.— Operating procedures for use of ACAS are contained in PANS-OPS (Doc 8168), Volume I, Part VIII, Chapter 3.

Note 3.— The phraseology to be used by controllers and pilots is contained in Part X, 3.1.2.

PART III. AREA CONTROL SERVICE

SEPARATION OF AIRCRAFT IN THE PROVISION OF AREA CONTROL SERVICE

1. General provisions for the separation of controlled traffic

1.1 Vertical or horizontal separation shall be provided:

- a) between all flights in Class A and B airspaces;
- b) between IFR flights in Class C, D and E airspaces;
- c) between IFR flights and VFR flights in Class C airspace;
- d) between IFR flights and special VFR flights; and
- e) between special VFR flights, when so prescribed by the appropriate ATS authority;

except, for the cases under b) above in airspace Classes D and E, during the hours of daylight when flights have been cleared to climb or descend subject to maintaining own separation and remaining in visual meteorological conditions.

Note 1.— See Section 13 regarding the granting of clearances in the circumstances referred to in the exception clause above.

Note 2.— The provisions governing holding are set forth in Part IV, Section 11.

1.2 No clearance shall be given to execute any manoeuvre that would reduce the spacing between two aircraft to less than the separation minimum applicable in the circumstances.

1.3 Larger separations than the specified minima should be applied whenever wake turbulence or exceptional circumstances such as unlawful interference call for extra precautions. This should be done with due regard to all relevant factors so as to avoid impeding the flow of air traffic by the application of excessive separations.

Note 1.— Unlawful interference with an aircraft constitutes a case of exceptional circumstances which might require

the application of separations larger than the specified minima, between the aircraft being subjected to unlawful interference and other aircraft.

Note 2.— Wake turbulence categorization of aircraft and longitudinal separation minima are contained in Part V, Section 16 and in Part VI, Section 7.

Note 3.— Detailed characteristics of wake vortices and their effect on aircraft are contained in the Air Traffic Services Planning Manual (Doc 9426), Part II, Section 5.

1.4 Where the type of separation or minimum used to separate two aircraft cannot be maintained, action shall be taken to ensure that another type of separation or another minimum exists or is established prior to the time when the previously used separation would be insufficient.

VERTICAL SEPARATION

2. Vertical separation application

2.1 Vertical separation is obtained by requiring aircraft using prescribed altimeter setting procedures to operate at different levels expressed in terms of flight levels or altitudes in accordance with the provisions in Part II, 12.1.

3. Vertical separation minimum

3.1 The vertical separation minimum (VSM) shall be:

- a) within designated airspace, subject to regional air navigation agreement: a nominal 300 m (1 000 ft) below FL 410 or a higher level where so prescribed for use under specified conditions, and a nominal 600 m (2 000 ft) at or above this level; and
- b) within other airspace: a nominal 300 m (1 000 ft) below FL 290 and a nominal 600 m (2 000 ft) at or above this level.

Note.— Guidance material relating to vertical separation is contained in the Manual on Implementation of a 300 m (1 000 ft) Vertical Separation Minimum Between FL 290 and FL 410 Inclusive (Doc 9574).

4. Minimum cruising level

4.1 Except when specifically authorized by the appropriate authority, cruising levels below the minimum flight altitudes established by the State shall not be assigned.

4.2 Area control centres shall, when circumstances warrant it, determine the lowest usable flight level or levels for the whole or parts of the control area for which they are responsible, and use it when assigning flight levels and pass it to pilots on request.

Note 1.— Unless otherwise prescribed by the State concerned, the lowest usable flight level is that flight level which corresponds to, or is immediately above, the established minimum flight altitude.

Note 2.— The portion of a control area for which a particular lowest usable flight level applies is determined in accordance with air traffic services requirements.

Note 3.— See Part II, Note 2 to Section 1.

5. Assignment of cruising levels

5.1 Except when traffic conditions and co-ordination procedures permit authorization of cruise climb, an area control centre shall normally authorize only one cruising level for an aircraft beyond its control area, i.e. that cruising level at which the aircraft will enter the next control area whether contiguous or not. Aircraft will be advised to request en route any subsequent cruising level changes desired.

5.1.1 Aircraft authorized to employ cruise climb techniques shall be cleared to operate between two levels or above a level.

5.2 If it is necessary to adjust the cruising level of an aircraft operating along an established ATS route extending partly within and partly outside controlled airspace and where the respective series of cruising levels are not identical, such adjustment shall, whenever possible, be effected within controlled airspace and, if suitably located, over a radio navigation aid.

Rules of the Air and Air Traffic Services (PANS-RAC)

5.3 When an aircraft has been cleared into a centre's control area at a cruising level which is below the established minimum cruising level for a subsequent portion of the route, action should be initiated by that area control centre to issue a revised clearance to the aircraft even though the pilot has not requested the necessary cruising level change.

5.4 When necessary, an aircraft may be cleared to change cruising level at a specified time, place or rate.

5.5 In so far as practicable, cruising levels of aircraft flying to the same destination shall be assigned in a manner that will be correct for an approach sequence at destination.

5.6 An aircraft at a cruising level shall normally have priority over other aircraft desiring that cruising level. When two or more aircraft are at the same cruising level, the preceding aircraft shall normally have priority.

5.7 An aircraft may be assigned a level previously occupied by another aircraft after the latter has reported vacating it. If, however, severe turbulence is known to exist, or the aircraft concerned is effecting a cruise climb, such assignment shall be withheld until the aircraft vacating the level has reported at another level separated by the required minimum.

5.8 The cruising levels, or, in the case of cruise climb, the range of levels, to be assigned to controlled flights shall be selected from those allocated to IFR flights in:

- a) the tables of cruising levels in Appendix 3 of Annex 2; or
- b) a modified table of cruising levels, when so prescribed in accordance with Appendix 3 of Annex 2 for flights above flight level 410;

except that the correlation of levels to track as prescribed therein shall not apply whenever otherwise indicated in air traffic control clearances or specified by the appropriate ATS authority in Aeronautical Information Publications.

6. Vertical separation during ascent or descent

6.1 Pilots in direct communication with each other may, with their concurrence, be cleared to maintain a specified vertical separation between their aircraft during ascent or descent.

HORIZONTAL SEPARATION

Note 1.— Nothing in the provisions detailed in Sections 7 and 8 hereunder precludes a State from establishing:

- a) *other minima for use in circumstances not prescribed; or*
- b) *additional conditions to those prescribed for the use of a given minimum;*

provided that the level of safety inherent in the provisions detailed in Sections 7 and 8 hereunder is at all times assured.

Note 2.— Provisions governing radar separation are set forth in Part VI, 7.3.

Note 3.— Details on track spacing between parallel routes are provided in Annex 11, Attachments A and B.

Note 4.— Attention is drawn to the following guidance material:

- a) Air Traffic Services Planning Manual (Doc 9426);
- b) Manual on Airspace Planning Methodology for the Determination of Separation Minima (Doc 9689); and
- c) Manual on Required Navigation Performance (RNP) (Doc 9613).

7. Lateral separation**7.1 Lateral separation application**

7.1.1 Lateral separation shall be applied so that the distance between those portions of the intended routes for which the aircraft are to be laterally separated is never less than an established distance to account for navigational inaccuracies plus a specified buffer. This buffer shall be determined by the appropriate authority and included in the lateral separation minima as an integral part thereof.

Note.— In the minima specified in 7.2 an appropriate buffer has already been included.

7.1.2 Lateral separation of aircraft at the same level is obtained by requiring operation on different routes or in different geographical locations as determined by visual observation, by the use of navigation aids or by the use of area navigation equipment.

7.1.3 When information is received indicating navigation equipment failure or deterioration below the navigation performance requirements, ATC shall then, as required, apply alternative separation minima.

7.2 Lateral separation criteria and minima

7.2.1 Means by which lateral separation may be applied include the following:

7.2.1.1 *Using the same or different geographic locations.* By position reports which positively indicate the aircraft are over different geographic locations as determined visually or by reference to a navigation aid (see Figure III-1).

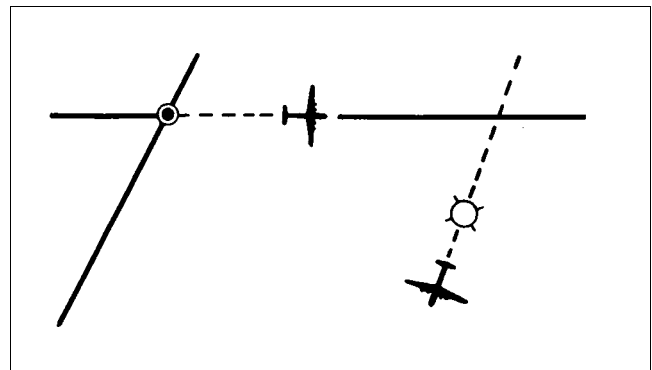

Figure III-1 (see 7.2.1.1)

7.2.1.2 *Using the same navigation aid or method.* By requiring aircraft to fly on specified tracks which are separated by a minimum amount appropriate to the navigation aid or method employed as follows:

- a) VOR: at least 15 degrees and at a distance of 28 km (15 NM) or more from the facility (see Figure III-2);
- b) NDB: at least 30 degrees and at a distance of 28 km (15 NM) or more from the facility (see Figure III-3);
- c) dead reckoning (DR): aircraft established on tracks diverging by at least 45 degrees and at a distance of 28 km (15 NM) or more from the point of intersection of the tracks, this point being determined either visually or by reference to a navigation aid and both aircraft are established outbound from the intersection (see Figure III-4); or

- d) RNAV operations: aircraft established on tracks which diverge by at least 15 degrees. Lateral separation exists when the protected airspace associated with the track of one aircraft does not overlap with the protected airspace associated with the track of the other aircraft. This is determined by applying the angular difference between two tracks and the appropriate protected airspace value. The derived value is expressed as a distance from the intersection of the two tracks at which lateral separation exists.

7.2.1.2.1 When aircraft are operating on tracks which are separated by considerably more than the foregoing minimum figures, States may reduce the distance at which lateral separation is achieved.

7.2.1.3 *Using different navigation aids or methods.* Lateral separation between aircraft using different navigation aids, or when one aircraft is using RNAV equipment, shall be established by ensuring that the derived protected airspaces for the navigation aid(s) or RNP do not overlap.

7.2.1.4 *RNAV operations (where RNP is specified) on parallel tracks or ATS routes.* Within designated airspace or on designated routes, where RNP is specified, lateral separation between RNAV-equipped aircraft may be obtained by requiring aircraft to be established on the centre lines of parallel tracks or ATS routes spaced at a distance which ensures that the protected airspace of the tracks or ATS routes does not overlap.

Note.— The spacing between parallel tracks or between parallel ATS route centre lines for which an RNP type is required will be dependent upon the relevant RNP type specified. Guidance material related to the spacing between tracks or ATS routes based on RNP type is contained in Annex 11, Attachment B.

7.2.1.5 *Transitioning into airspace where a greater lateral separation minimum applies.* By requiring aircraft to fly on specified tracks:

- a) which are separated by an appropriate minimum; and then
- b) diverge by at least 15 degrees until the applicable lateral separation minimum is established; and
- c) it is possible to ensure, by means approved by the appropriate ATS authority, that aircraft have the navigation capability necessary to ensure accurate track guidance.

8. Longitudinal separation

8.1 Longitudinal separation application

8.1.1 Longitudinal separation shall be applied so that the spacing between the estimated positions of the aircraft being separated is never less than a prescribed minimum. Longitudinal separation between aircraft following the same or diverging tracks may be maintained by application of the Mach number technique, when so prescribed on the basis of regional air navigation agreement.

Note.— Attention is drawn to the guidance material contained in the Air Traffic Services Planning Manual (Doc 9426) regarding the application of the Mach number technique to separation of subsonic aircraft.

8.1.2 Longitudinal separation shall be established by requiring aircraft to depart at a specified time, to lose time to arrive over a geographical location at a specified time, or to hold over a geographical location until a specified time.

8.1.3 Longitudinal separation between supersonic aircraft during the transonic acceleration and supersonic phases of flight should normally be established by appropriate timing of the start of transonic acceleration rather than by the imposition of speed restrictions in supersonic flight.

8.1.4 For the purpose of application of longitudinal separation, the terms *same track*, *reciprocal tracks* and *crossing tracks* shall have the following meanings:

- a) Same track (see Figure III-5 below):

same direction tracks and intersecting tracks or portions thereof, the angular difference of which is less than 45 degrees or more than 315 degrees, and whose protection areas overlap.

- b) Reciprocal tracks (see Figure III-6 below):

opposite tracks and intersecting tracks or portions thereof, the angular difference of which is more than 135 degrees but less than 225 degrees, and whose protection areas overlap.

- c) Crossing tracks (see Figure III-7 below):

intersecting tracks or portions thereof other than those specified in a) and b) above.

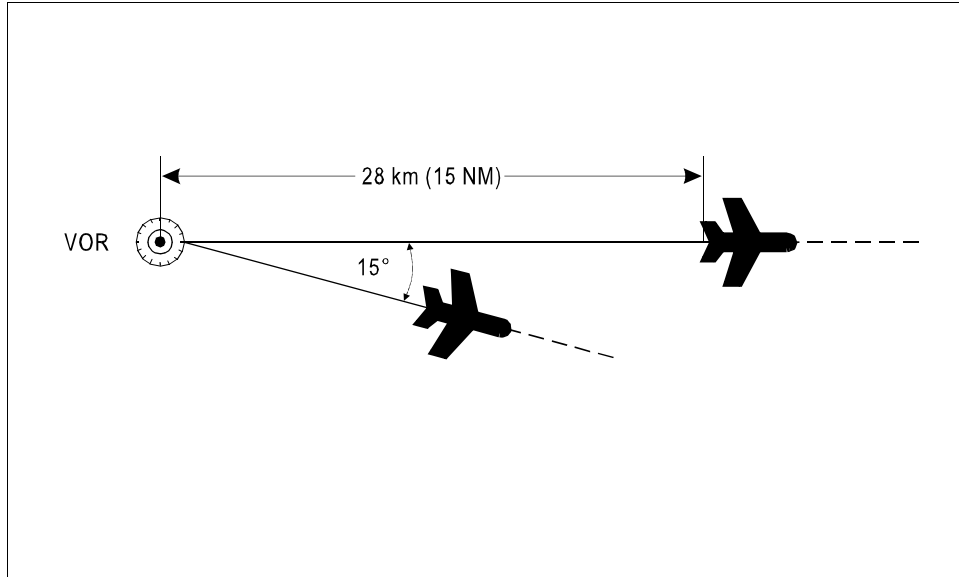

Figure III-2 (see 7.2.1.2 a))

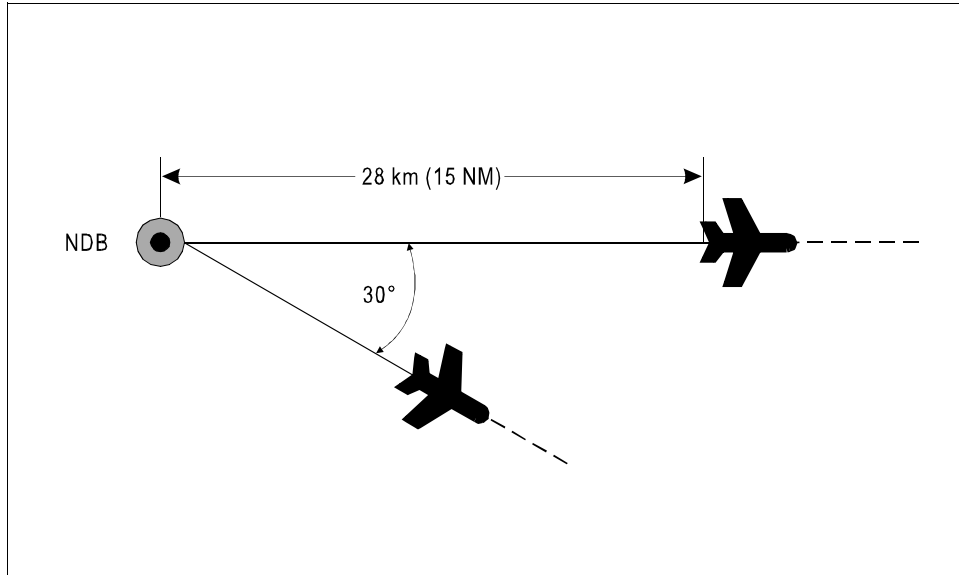

Figure III-3 (see 7.2.1.2 b))

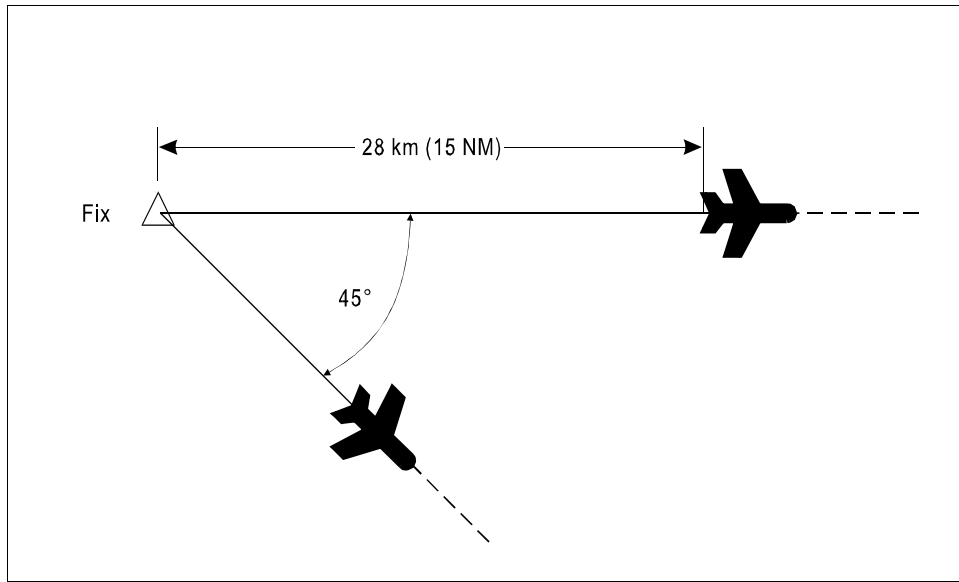

Figure III-4 (see 7.2.1.2 c))

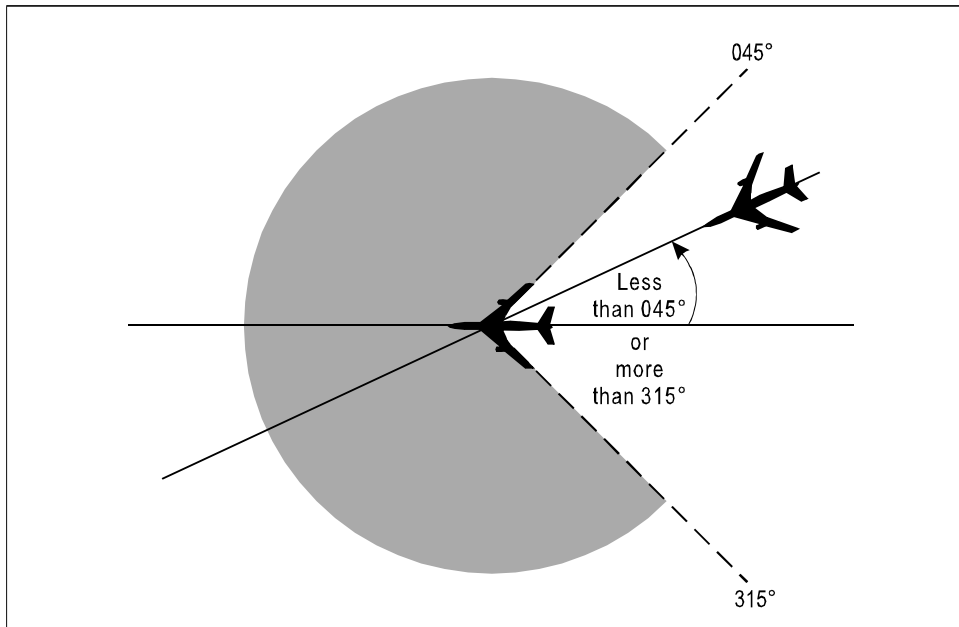

Figure III-5 (see 8.1.4 a))

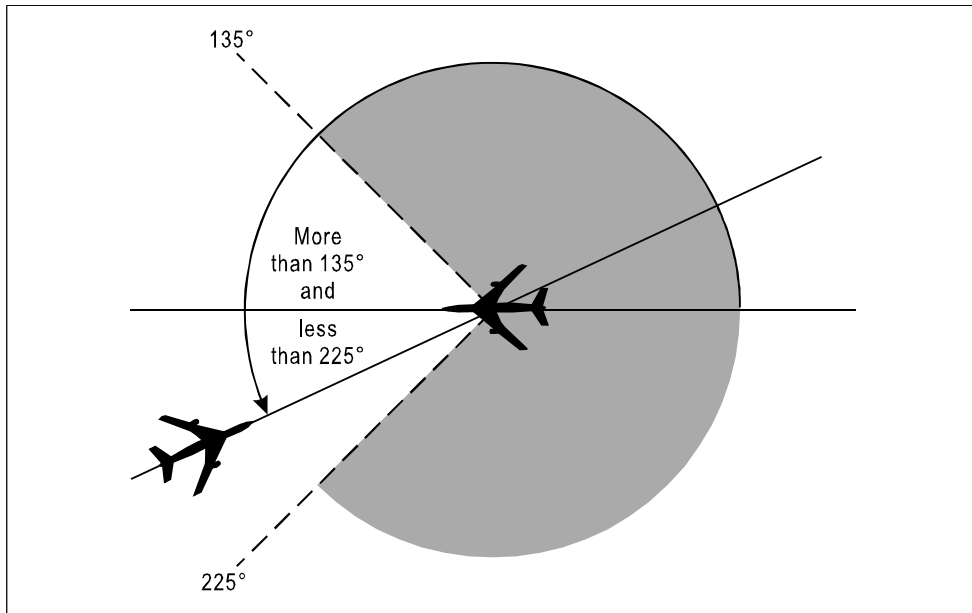

Figure III-6 (see 8.1.4 b))

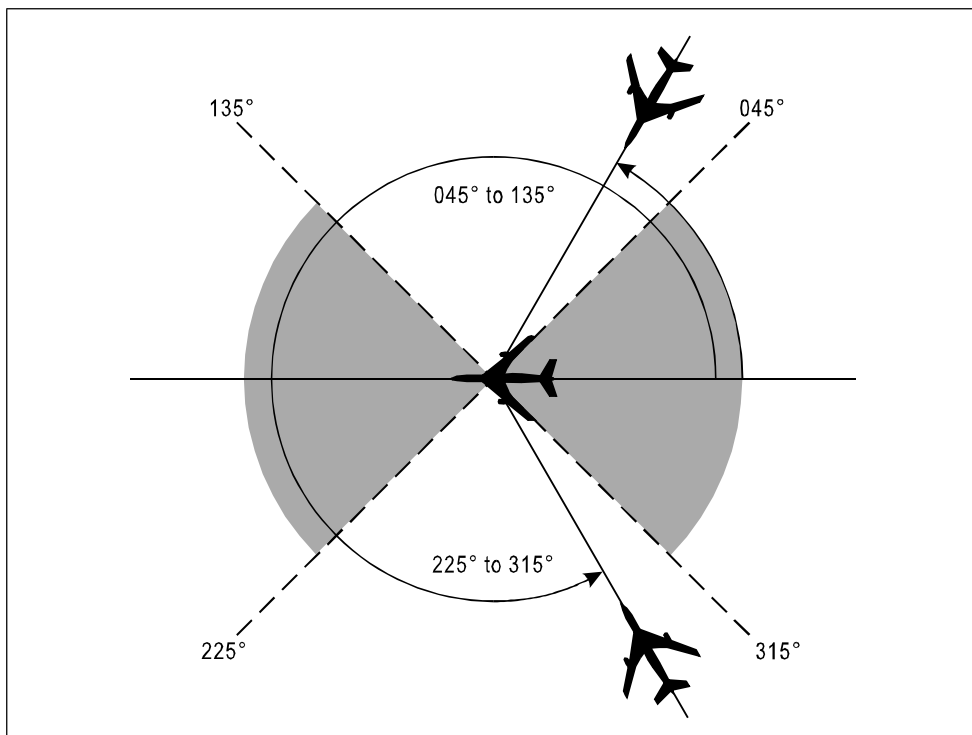

Figure III-7 (see 8.1.4 c))

8.2 Longitudinal separation minima based on time

8.2.1 *Aircraft at the same cruising level*

8.2.1.1 *Aircraft flying on the same track:*

- a) 15 minutes (see Figure III-8); or
- b) 10 minutes, if navigation aids permit frequent determination of position and speed (see Figure III-9); or
- c) 5 minutes in the following cases, provided that in each case the preceding aircraft is maintaining a true airspeed of 37 km/h (20 kt) or more faster than the succeeding aircraft (see Figure III-10):
 - i) between aircraft that have departed from the same aerodrome;
 - ii) between en-route aircraft that have reported over the same exact reporting point;
 - iii) between departing and en-route aircraft after the en-route aircraft has reported over a fix that is so located in relation to the departure point as to ensure that five-minute separation can be established at the point the departing aircraft will join the air route; or
- d) 3 minutes in the cases listed under c) provided that in each case the preceding aircraft is maintaining a true airspeed of 74 km/h (40 kt) or more faster than the succeeding aircraft (see Figure III-11).

8.2.1.2 *Aircraft flying on crossing tracks:*

- a) 15 minutes (see Figure III-12); or
- b) 10 minutes if navigation aids permit frequent determination of position and speed (see Figure III-13).

8.2.2 *Aircraft climbing or descending*

8.2.2.1 *Traffic on the same track.* When an aircraft will pass through the level of another aircraft on the same track, the following minimum longitudinal separation shall be provided:

- a) 15 minutes while vertical separation does not exist (see Figures III-14A and III-14B); or

Rules of the Air and Air Traffic Services (PANS-RAC)

- b) 10 minutes while vertical separation does not exist, provided that such separation is authorized only where navigation aids permit frequent determination of position and speed (see Figures III-15A and III-15B); or
- c) 5 minutes while vertical separation does not exist, provided that the level change is commenced within 10 minutes of the time the second aircraft has reported over an exact reporting point (see Figures III-16A and III-16B).

Note.— To facilitate application of the procedure where a considerable change of level is involved, a descending aircraft may be cleared to some convenient level above the lower aircraft, or a climbing aircraft to some convenient level below the higher aircraft, to permit a further check on the separation that will obtain while vertical separation does not exist.

8.2.2.2 *Traffic on crossing tracks:*

- a) 15 minutes while vertical separation does not exist (see Figures III-17A and III-17B); or
- b) 10 minutes while vertical separation does not exist if navigation aids permit frequent determination of position and speed (see Figures III-18A and III-18B).

8.2.3 *Traffic on reciprocal tracks.* Where lateral separation is not provided, vertical separation shall be provided for at least ten minutes prior to and after the time the aircraft are estimated to pass, or are estimated to have passed (see Figure III-19). Provided that it has been determined that the aircraft have passed each other, this minimum need not apply.

8.3 Longitudinal separation minima based on distance using DME

8.3.1 Separation shall be established by maintaining not less than specified distance(s) between aircraft positions as reported by reference to DME in conjunction with other appropriate navigation aids. Direct controller-pilot communication shall be maintained while such separation is used.

8.3.1.1 *Aircraft at the same cruising level*

8.3.1.1.1 *Aircraft on the same track:*

- a) 37 km (20 NM), provided:
 - i) each aircraft utilizes “on-track” DME stations; and

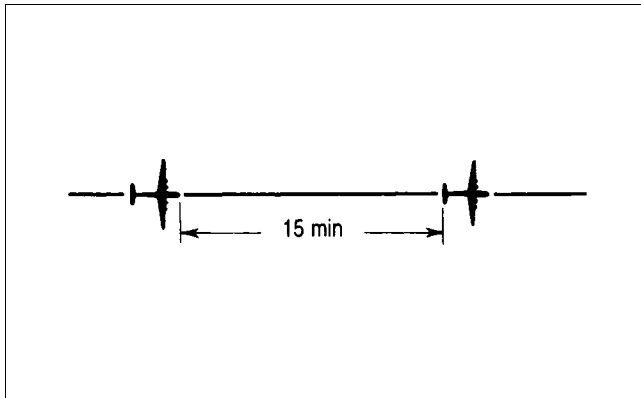

Figure III-8 (see 8.2.1.1 d))

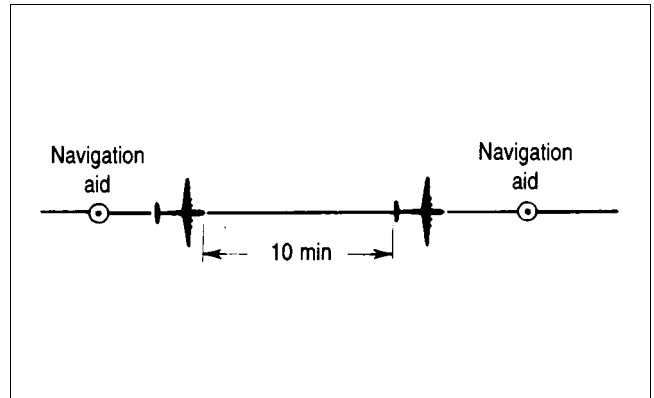

Figure III-9 (see 8.2.1.1 b))

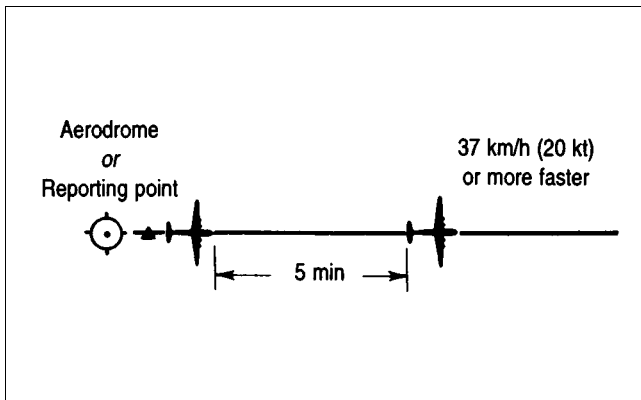

Figure III-10 (see 8.2.1.1 c))

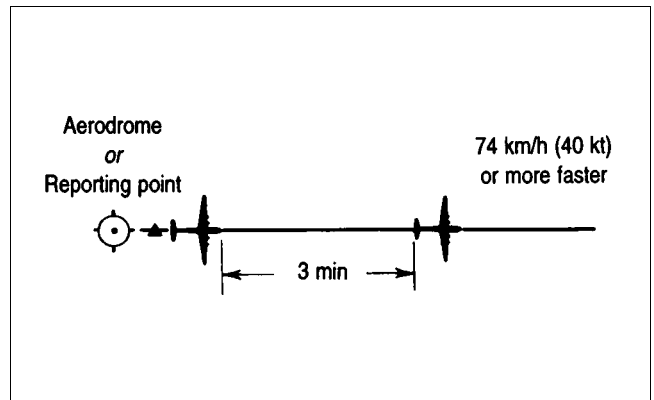

Figure III-11 (see 8.2.1.1 d))

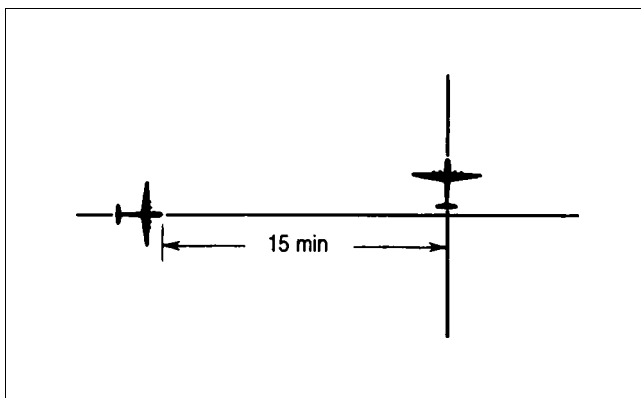

Figure III-12 (see 8.2.1.2 a))

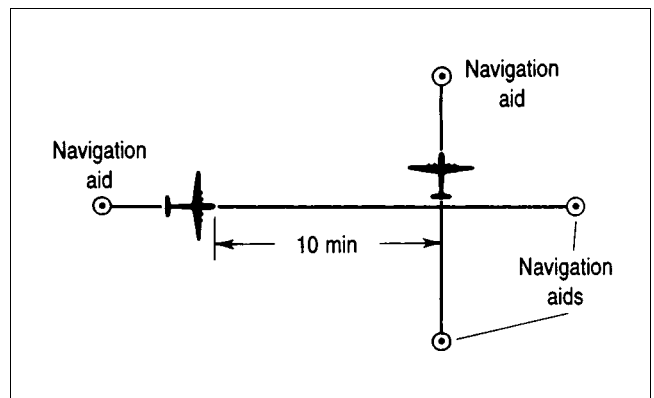

Figure III-13 (see 8.2.1.2 b))

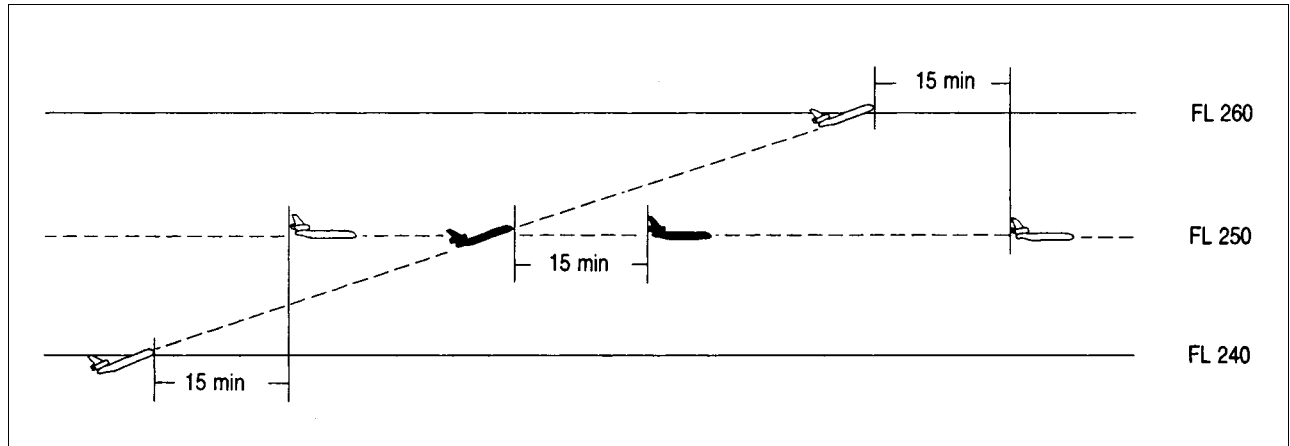

Figure III-14A (see 8.2.2.1 a))

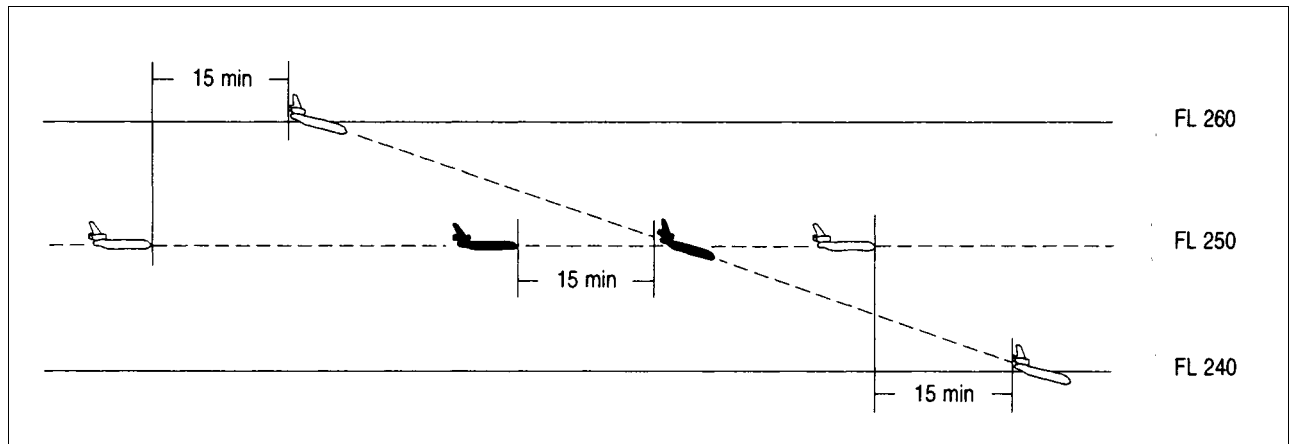

Figure III-14B (see 8.2.2.1 a))

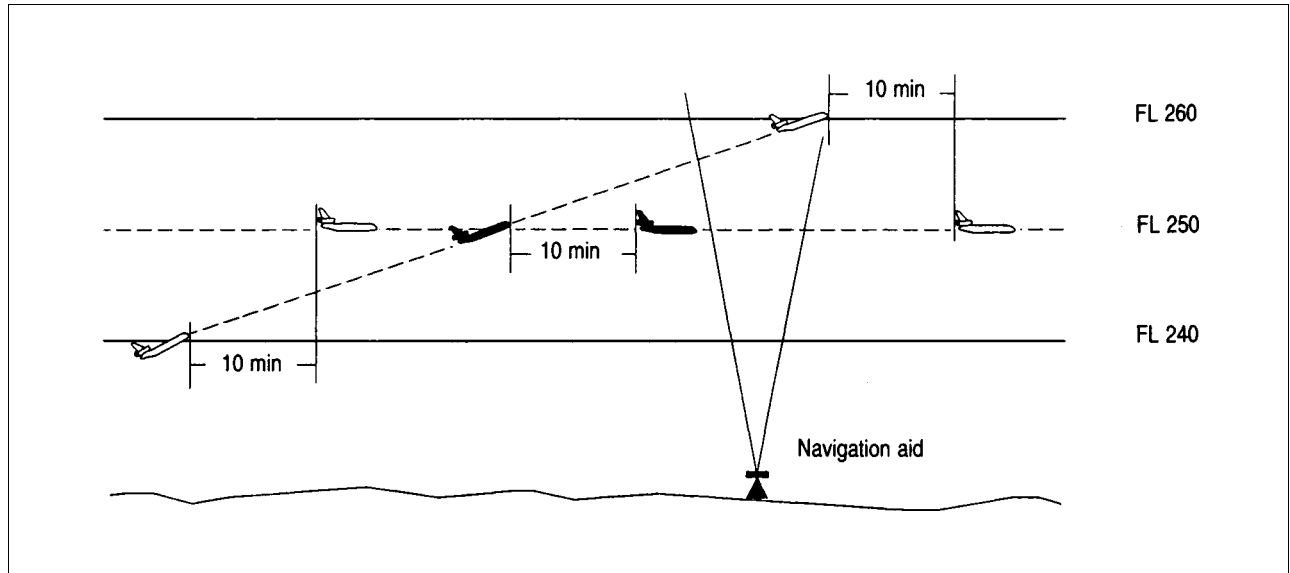

Figure III-15A (see 8.2.2.1 b))

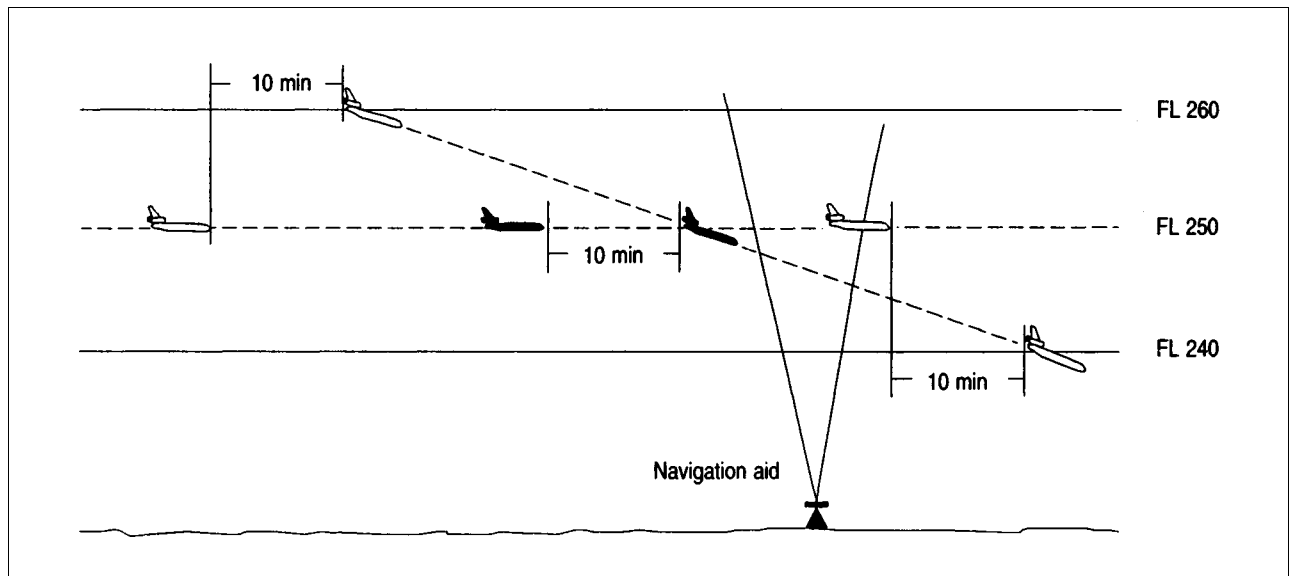

Figure III-15B (see 8.2.2.1 b))

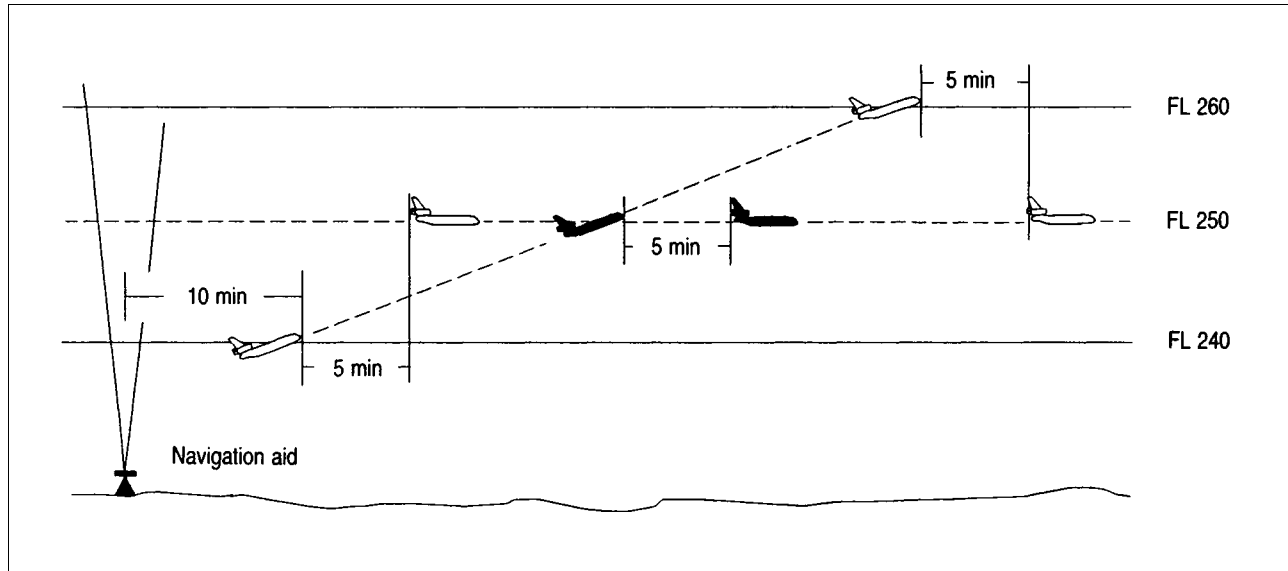

Figure III-16A (see 8.2.2.1 c))

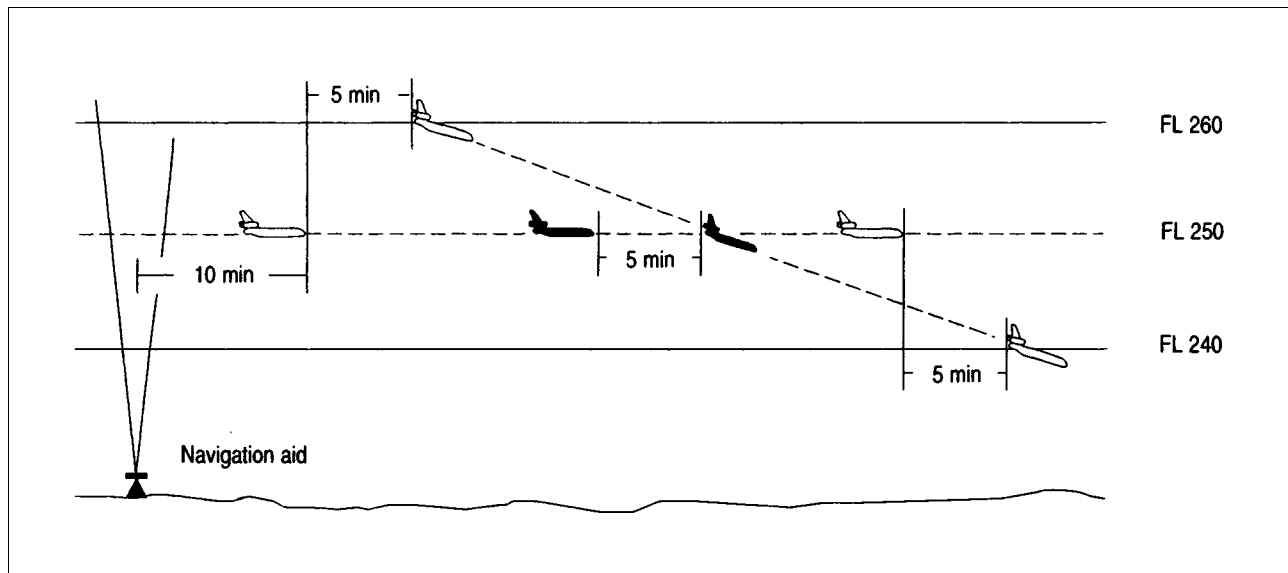

Figure III-16B (see 8.2.2.1 c))

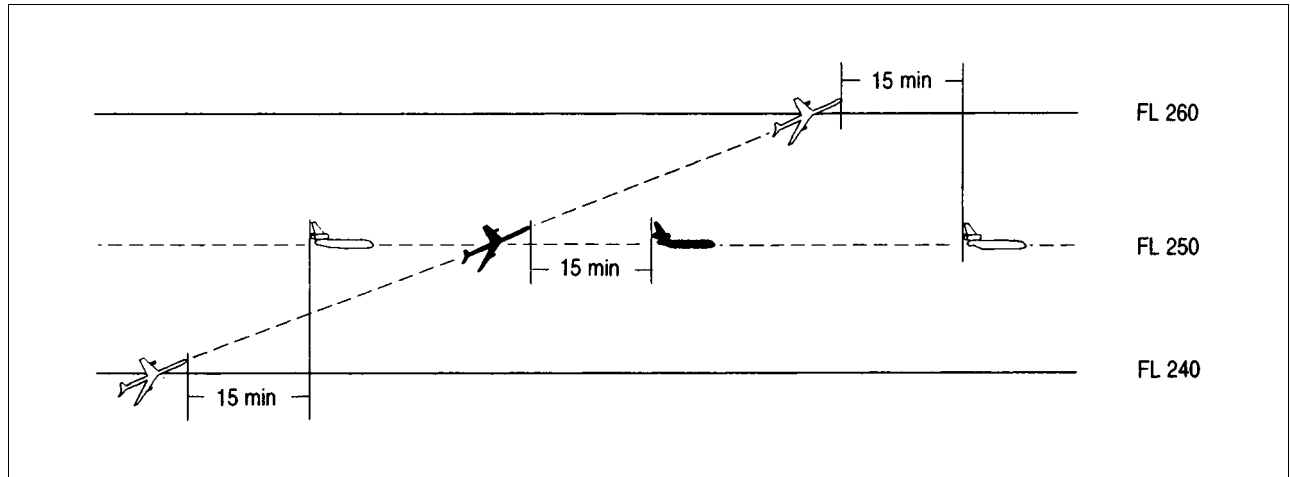

Figure III-17A (see 8.2.2.2 a))

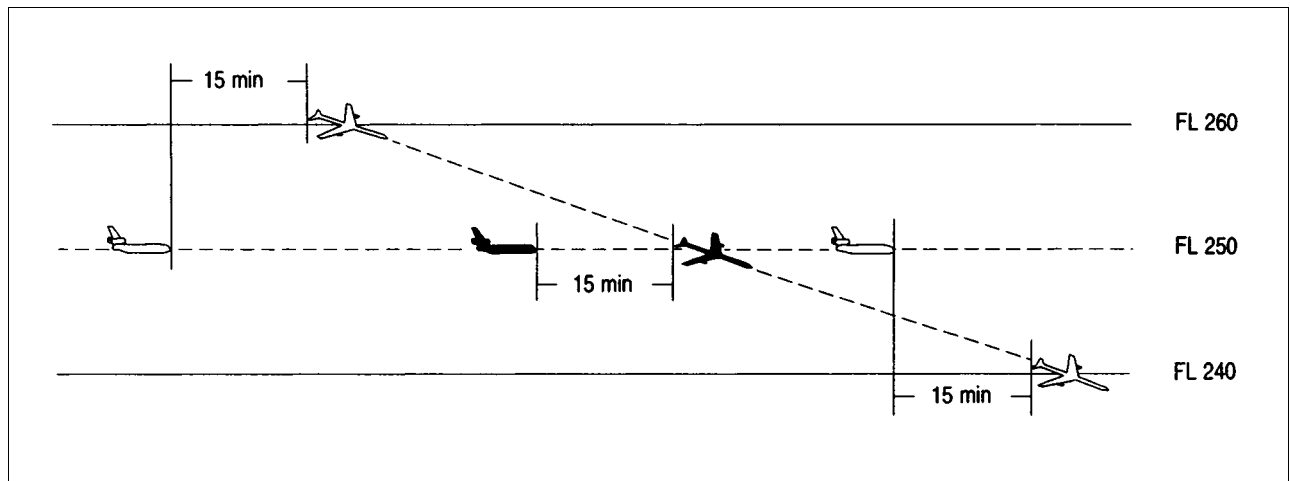

Figure III-17B (see 8.2.2.2 a))

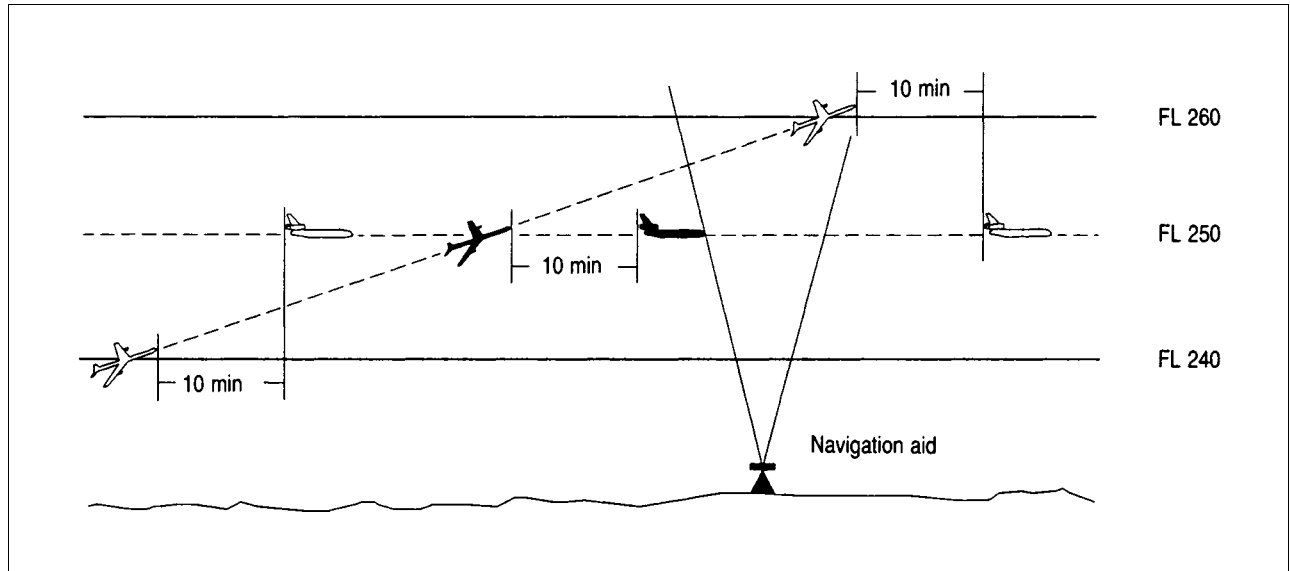

Figure III-18A (see 8.2.2.2 b))

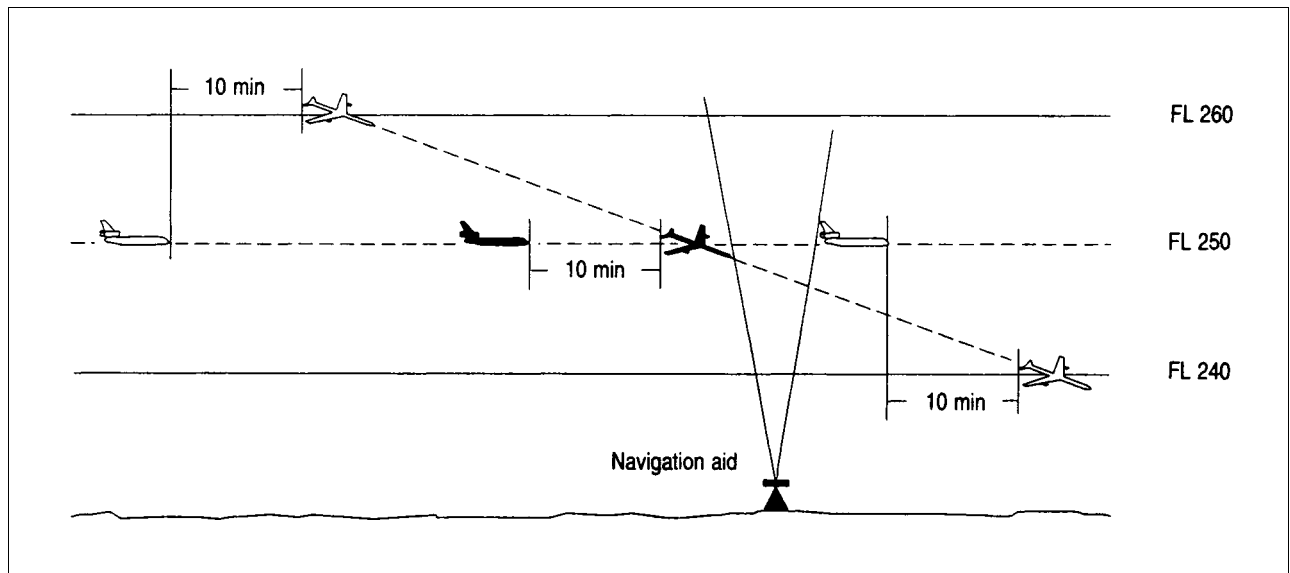

Figure III-18B (see 8.2.2.2 b))

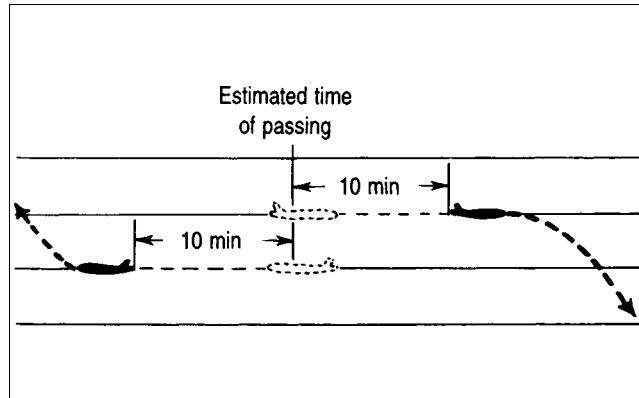

Figure III-19 (see 8.2.3)

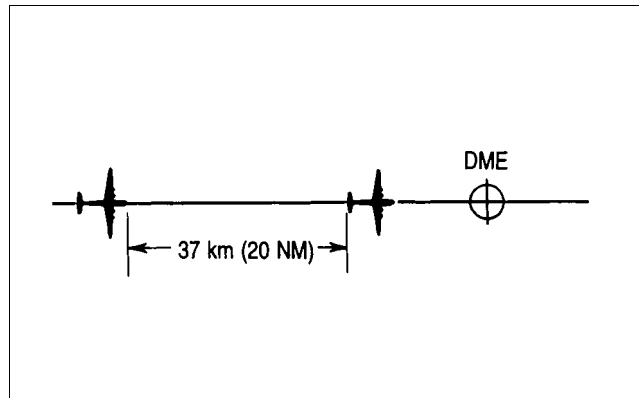

Figure III-20 (see 8.3.1.1.1 a))

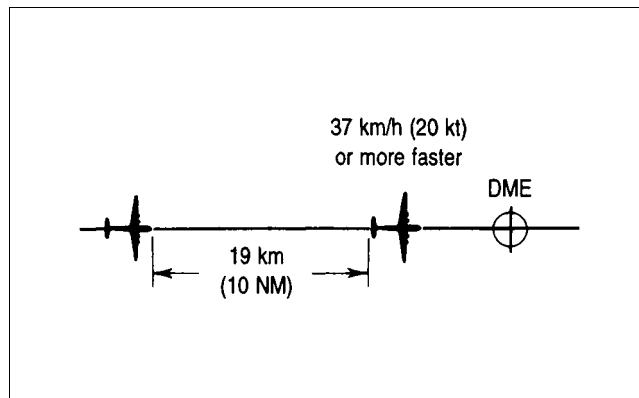

Figure III-21 (see 8.3.1.1.1 b))

- ii) separation is checked by obtaining simultaneous DME readings from the aircraft at frequent intervals to ensure that the minimum will not be infringed (see Figure III-20);

b) 19 km (10 NM) provided:

- i) the leading aircraft maintains a true airspeed of 37 km/h (20 kt) or more faster than the succeeding aircraft;
- ii) each aircraft utilizes “on-track” DME stations; and
- iii) separation is checked by obtaining simultaneous DME readings from the aircraft at such intervals as are necessary to ensure that the minimum is established and will not be infringed (see Figure III-21).

8.3.1.1.2 *Aircraft on crossing tracks.* The longitudinal separation prescribed in 8.3.1.1.1 shall also apply provided that each aircraft reports distance from the station located at the crossing point of the tracks and that the relative angle between the tracks is less than 90 degrees (see Figures III-22A and III-22B).

8.3.1.2 *Aircraft climbing or descending on the same track:* 19 km (10 NM) while vertical separation does not exist, provided:

- a) each aircraft utilizes “on-track” DME stations;
- b) one aircraft maintains a level while vertical separation does not exist; and
- c) separation is established by obtaining simultaneous DME readings from the aircraft (see Figures III-23A and III-23B).

Note.— To facilitate application of the procedure where a considerable change of level is involved, a descending aircraft may be cleared to some convenient level above the lower aircraft, or a climbing aircraft to some convenient level below the higher aircraft, to permit a further check on the separation that will obtain while vertical separation does not exist.

8.3.1.3 *Aircraft on reciprocal tracks.* Aircraft utilizing on-track DME may be cleared to climb or descend to or through the levels occupied by other aircraft utilizing on-track DME, provided that it has been positively established that the

aircraft have passed each other and are at least 10 NM apart, or such other value as prescribed by the appropriate ATS authority.

8.4 Longitudinal separation minima
with Mach number technique based on time

8.4.1 Turbojet aircraft shall adhere to the Mach number approved by ATC and shall request ATC approval before making any changes thereto. If it is essential to make an immediate temporary change in the Mach number (e.g. due to turbulence), ATC shall be notified as soon as possible that such a change has been made.

8.4.2 If it is not feasible, due to aircraft performance, to maintain the last assigned Mach number during en-route climbs and descents, pilots of aircraft concerned shall advise ATC at the time of the climb/descent request.

8.4.3 Provided that:

- a) the aircraft concerned have reported over the same reporting point and follow the same track or continuously diverging tracks until some other form of separation is provided; or
- b) if the aircraft have not reported over the same reporting point and it is possible to ensure, by radar or other means, that the appropriate time interval will exist at the common point from which they either follow the same track or continuously diverging tracks;

when Mach number technique is applied, minimum longitudinal separation between turbojet aircraft on the same track, whether in level, climbing or descending flight shall be:

- i) 10 minutes; or
- ii) between 9 and 5 minutes inclusive, provided:

the preceding aircraft is maintaining a Mach number greater than the following aircraft in accordance with the following table:

- 9 minutes, if the preceding aircraft is Mach 0.02 faster than the following aircraft;
- 8 minutes, if the preceding aircraft is Mach 0.03 faster than the following aircraft;

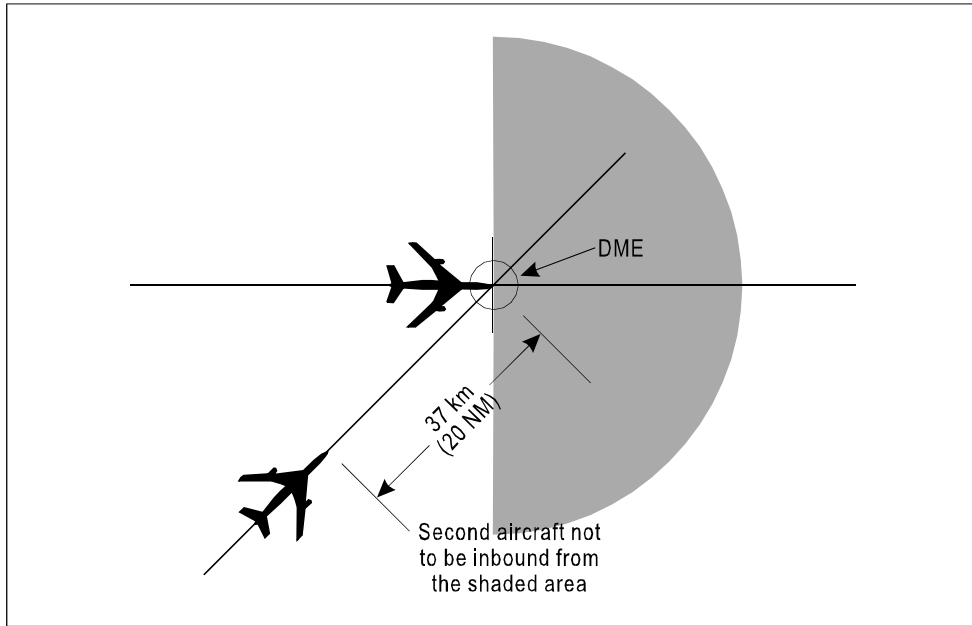

Figure III-22A (see 8.3.1.1.2)

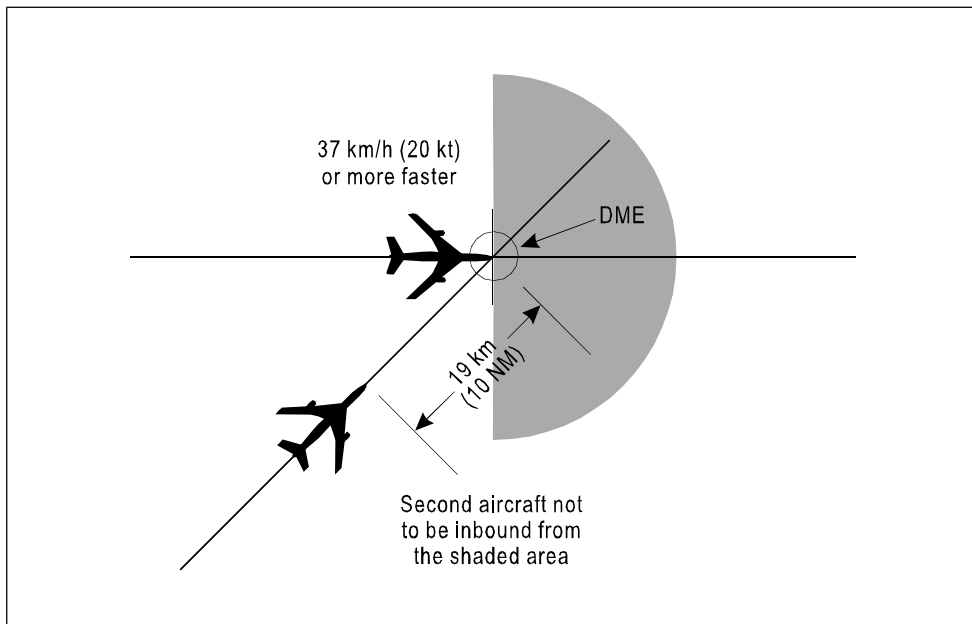

Figure III-22B (see 8.3.1.1.2)

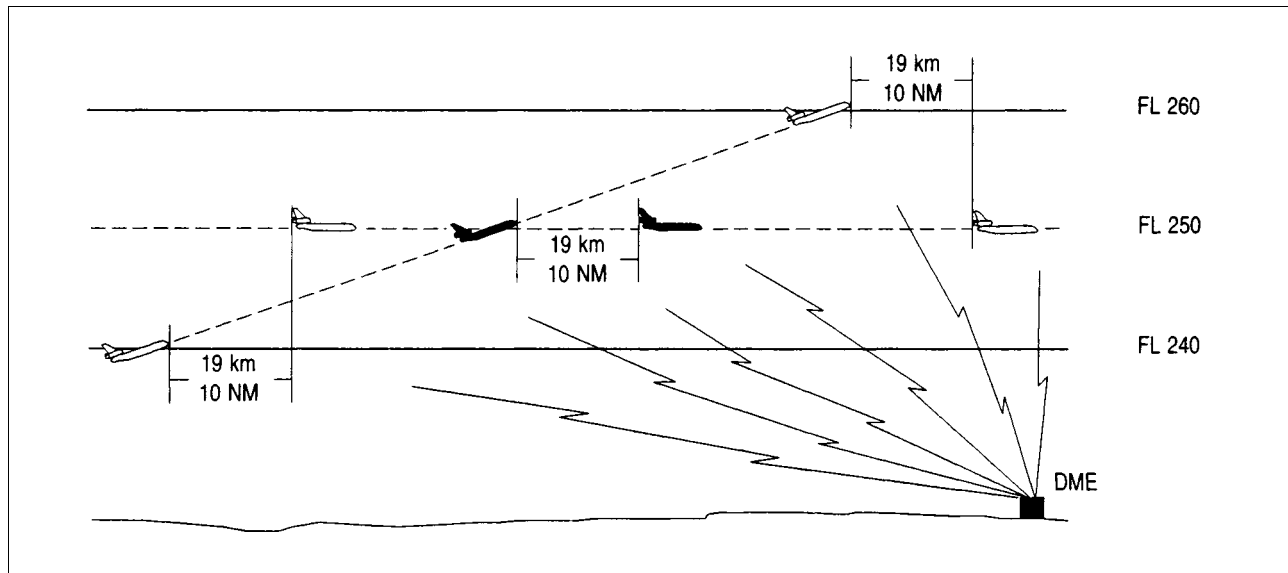

Figure III-23A (see 8.3.1.2 c)

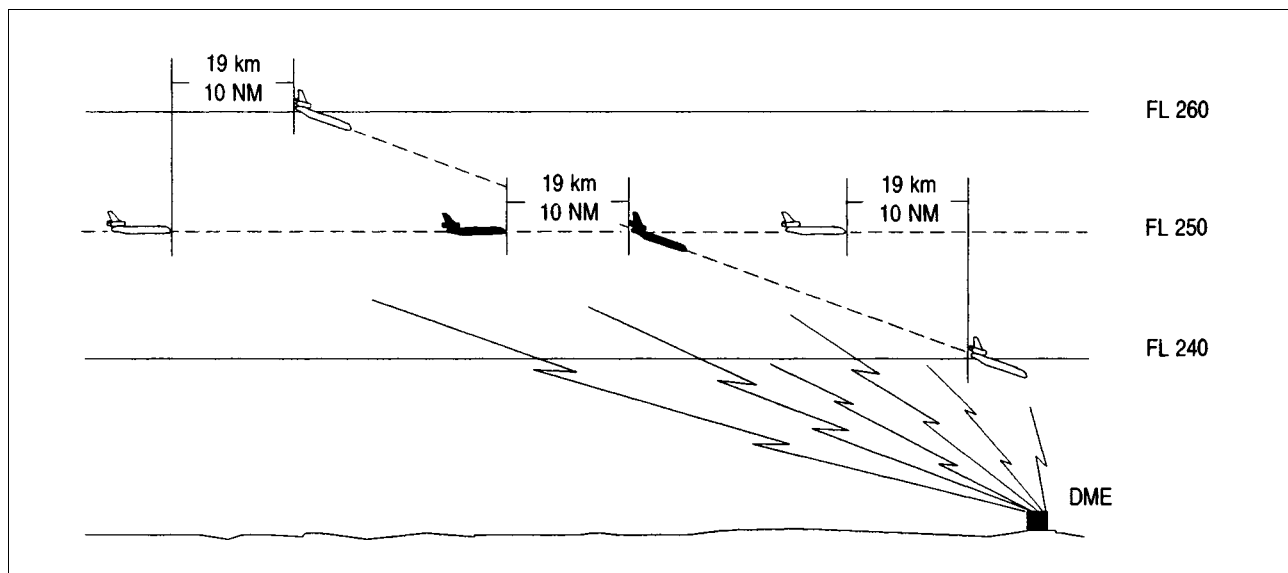

Figure III-23B (see 8.3.1.2 c)

- 7 minutes, if the preceding aircraft is Mach 0.04 faster than the following aircraft;
- 6 minutes, if the preceding aircraft is Mach 0.05 faster than the following aircraft;
- 5 minutes, if the preceding aircraft is Mach 0.06 faster than the following aircraft.

8.4.4 When the 10-minute longitudinal separation minimum with Mach number technique is applied, the preceding aircraft shall maintain a Mach number equal to or greater than that maintained by the following aircraft.

8.5 Longitudinal separation minima based on distance using RNAV

Note.— *Guidance material on RNAV operations is contained in the Manual on Required Navigation Performance (RNP) (Doc 9613).*

8.5.1 Separation shall be established by maintaining not less than the specified distance between aircraft positions as reported by reference to RNAV equipment. Direct controller-pilot communications should be maintained, while such separation is used. Where high frequency or general purpose extended range very high frequency air-ground communication channels are used for area control service and are worked by air-ground communicators, suitable arrangements shall be made to permit direct controller-pilot communications, or monitoring by the controller of all air-ground communications.

8.5.1.1 To assist pilots to readily provide the required RNAV distance information, such position reports should, wherever possible, be referenced to a common way-point ahead of both aircraft.

8.5.2 RNAV distance-based separation may be applied between RNAV-equipped aircraft when operating on designated RNAV routes or on ATS routes defined by VOR.

8.5.3 A 150 km (80 NM) RNAV distance-based separation minimum may be used on same-direction tracks in lieu of a 10-minute longitudinal separation minimum. When applying this separation minimum between aircraft on same-direction track, the Mach number technique (MNT) shall be applied, and the preceding aircraft shall maintain a Mach number equal to or greater than that maintained by the following aircraft.

8.5.4 Turbo-jet aircraft shall adhere to the Mach number approved by ATC and shall request ATC approval before

making any changes thereto. If it is essential to make an immediate temporary change in the Mach number (e.g. due to turbulence), ATC shall be notified as soon as possible that such a change has been made.

8.5.4.1 If it is not feasible, due to aircraft performance, to maintain the last assigned Mach number during en-route climbs and descents, pilots of aircraft concerned shall advise ATC at the time of the climb/descent request.

8.5.5 RNAV distance-based separation minima shall not be applied after ATC has received pilot advice indicating navigation equipment deterioration or failure.

8.5.6 Aircraft at the same cruising level

8.5.6.1 *Aircraft on the same track.* (See Figure III-24.) A 150 km (80 NM) RNAV distance-based separation minimum may be used provided:

- a) each aircraft reports its distance to or from the same “on-track” way-point; and
- b) separation is checked by obtaining simultaneous RNAV distance readings from the aircraft at frequent intervals to ensure that the minimum will not be infringed.

8.5.7 Aircraft climbing or descending on the same track

8.5.7.1 A 150 km (80 NM) RNAV distance-based separation minimum may be used while vertical separation does not exist, provided:

- a) each aircraft reports its distance to or from the same “on-track” way-point;
- b) one aircraft maintains a level while vertical separation does not exist; and
- c) separation is established by obtaining simultaneous RNAV distance readings from the aircraft (see Figures III-25A and III-25B).

Note.— *To facilitate application of the procedure where a considerable change of level is involved, a descending aircraft may be cleared to some convenient level above the lower aircraft, or a climbing aircraft to some convenient level below the higher aircraft, to permit a further check on the separation that will obtain while vertical separation does not exist.*

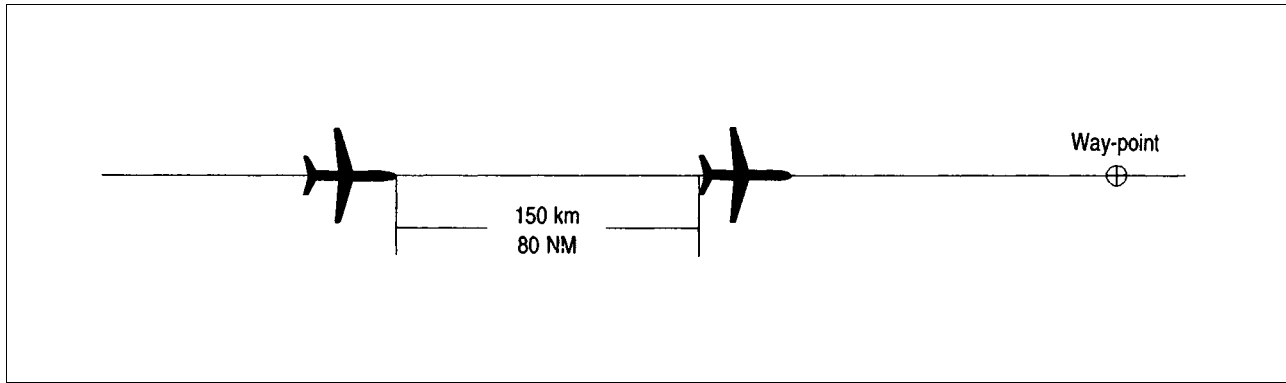

Figure III-24 (see 8.5.6.1)

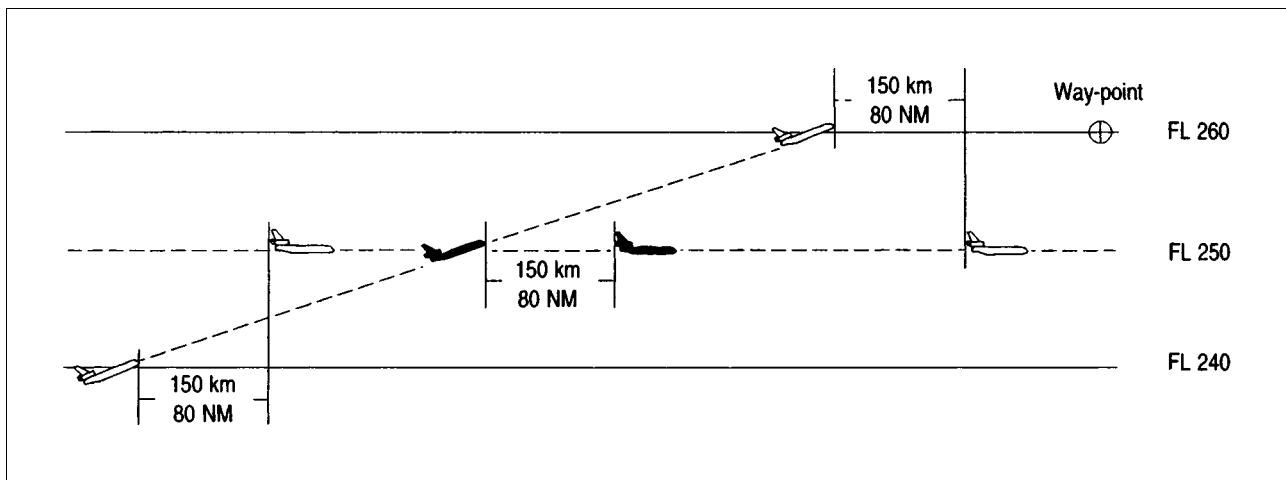

Figure III-25A (see 8.5.7.1 c)

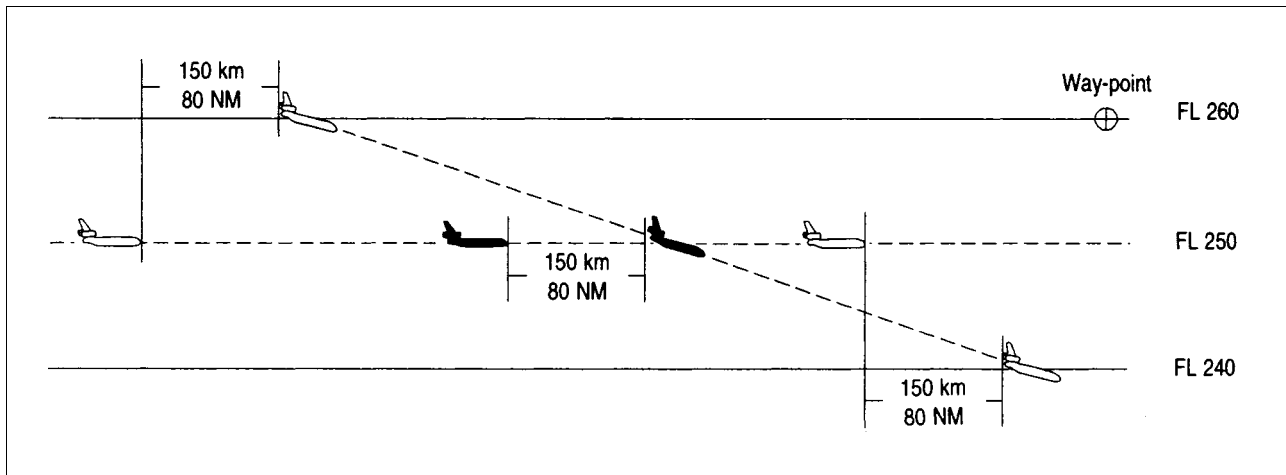

Figure III-25B (see 8.5.7.1 c)

8.5.8 Aircraft on reciprocal tracks

8.5.8.1 Aircraft utilizing RNAV may be cleared to climb or descend to or through the levels occupied by other aircraft utilizing RNAV provided that it has been positively established by simultaneous RNAV distance readings to or from the same “on-track” way-point that the aircraft have passed each other by at least 150 km (80 NM) (see Figure III-26).

8.6 Longitudinal separation minima based on distance using RNAV where RNP is specified

Note.— Guidance material is contained in Attachment B to Annex 11, the Manual on Required Navigation Performance (RNP) (Doc 9613), the Air Traffic Services Planning Manual (Doc 9426) and the Manual on Airspace Planning Methodology for the Determination of Separation Minima (Doc 9689).

8.6.1 Within designated airspace, or on designated routes, separation standards in accordance with the provisions of this section (8.6) may be used, subject to regional air navigation agreements.

8.6.2 Separation shall be established by maintaining not less than the specified distance between aircraft positions as reported by reference to the same “on track” way-point, whenever possible ahead of both aircraft, or by means of an automated position reporting system.

Note.— The term “on track” means that the aircraft is flying either toward or away from the station or way-point.

8.6.2.1 When information is received indicating navigation equipment failure or deterioration below the navigation performance requirements, ATC shall then, as required, apply alternative separation minima.

8.6.2.2 Direct controller-pilot communications shall be maintained while applying a distance-based separation minima. Direct controller-pilot communications shall be voice or controller-pilot data link communications (CPDLC). The communication criteria necessary for CPDLC to satisfy the requirement for direct controller-pilot communications shall be established by an appropriate safety assessment.

Note.— The communication criteria which are used as a basis for the derivation of the separation minima in this section are set out in Appendix 5 of the Manual on Airspace Planning Methodology for the Determination of Separation Minima (Doc 9689). Guidance material for CPDLC is contained in the Manual of Air Traffic Services Data Link Applications (Doc 9694).

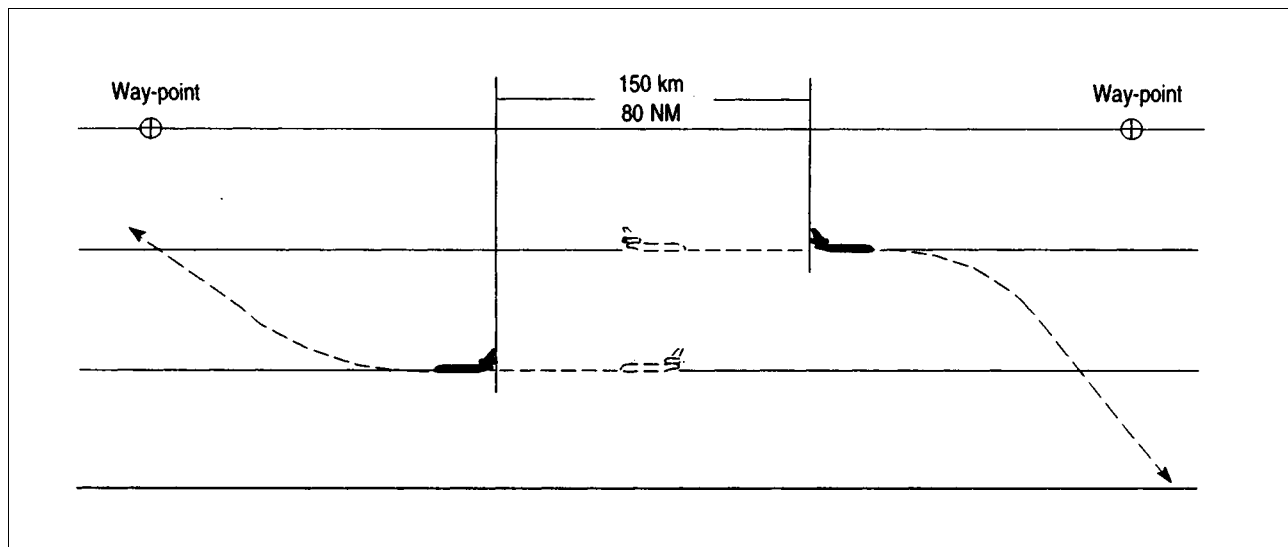

Figure III-26 (see 8.5.8.1)

8.6.2.2.1 Prior to and during the application of a distance-based separation minimum, the controller should determine the adequacy of the available communication link, considering the time element required to receive replies from two or more aircraft, and the overall workload/traffic volume associated with the application of such minima.

8.6.2.3 When aircraft are at, or are expected to reduce to, the minimum separation applicable, speed control techniques, including assigning Mach number, shall be applied to ensure that the minimum distance exists throughout the period of application of the minima.

8.6.2.4 Where a considerable change of level is involved using distance-based separation, a descending aircraft may be cleared to some convenient level above the lower aircraft, or a climbing aircraft to some convenient level below the higher aircraft (e.g. 4 000 ft or less) to permit a further check on the separation that will be maintained while vertical separation does not exist.

8.6.3 *Longitudinal distance-based separation minima in an RNP RNAV environment*

8.6.3.1 For aircraft cruising, climbing or descending on the same track, the following separation standards may be used:

| <i>Separation standard</i> | <i>RNP type</i> | <i>Communication requirement</i> | <i>Surveillance requirement</i> | <i>Distance verification requirements</i> |
|----------------------------|-----------------|--|---------------------------------|---|
| 80 NM | 20 | Direct controller-pilot communications (see 8.5.1) | Procedural position reports | At least every 60 minutes |
| 50 NM | 10 | Direct controller-pilot communications | Procedural position reports | At least every 30 minutes |

Note 1.— It should be noted that the separation standards depicted above are based on safety assessments performed specifically for a particular network of tracks or routes. As such, the assessments evaluated traffic characteristics which might be unique to the network being assessed.

Note 2.— The separation minima above were developed in accordance with a collision risk analysis which dictates conditions under which these minima can be applied.

Note 3.— Detailed information on the analysis used to determine these separation minima and on performing safety

assessments is contained in the Manual on Airspace Planning Methodology for the Determination of Separation Minima (Doc 9689).

8.6.3.1.1 During the application of the 50 NM separation minimum, when an aircraft fails to report its position, the controller shall take action within 3 minutes to establish communication. If communication has not been established within 8 minutes of the time the report should have been received, the controller shall take action to apply an alternative form of separation.

8.6.3.1.1.1 Where automated position reporting applies, a common time reference shall be used.

8.6.3.2 Aircraft may be cleared to climb or descend to or through the levels occupied by the other provided that it has been positively established that the aircraft have passed each other by the applicable separation standard.

REDUCTION IN SEPARATION MINIMA

9. The separation minima detailed in 7 and 8 may be reduced in the following circumstances.

9.1 As determined by the appropriate ATS authority, after prior consultation with the aircraft operators, as appropriate:

- a) when special electronic or other aids enable the pilot-in-command of an aircraft to determine accurately the aircraft's position and when adequate communication facilities exist for that position to be transmitted without delay to the appropriate air traffic control unit; or
- b) when, in association with rapid and reliable communication facilities, radar-derived information of an aircraft's position is available to the appropriate air traffic control unit; or
- c) when special electronic or other aids enable the air traffic controller to predict rapidly and accurately the flight paths of aircraft and adequate facilities exist to verify frequently the actual aircraft positions with the predicted positions; or
- d) when RNAV-equipped aircraft operate within the coverage of electronic aids that provide the necessary updates to maintain navigation accuracy.

Note.— Attention is drawn to the guidance material contained in the Air Traffic Services Planning Manual (Doc 9426) regarding conditions governing the reduction of separation minima.

9.2 In accordance with regional air navigation agreements, after prior consultation with the aircraft operators, when:

- a) special electronic, area navigation or other aids enable the aircraft to closely adhere to their current flight plans; and
- b) the air traffic situation is such that the conditions in 9.1 a) regarding communications between pilots and the appropriate ATC unit or units need not necessarily be met to the degree specified therein, in order to maintain an adequate level of safety.

AIR TRAFFIC CONTROL CLEARANCES

10. Issuance of air traffic control clearances

10.1 Departing aircraft

10.1.1 Area control centres shall forward a clearance to approach control offices or aerodrome control towers with the least possible delay after receipt of request made by these units, or prior to such request if practicable.

10.2 En-route aircraft

10.2.1 Air traffic control clearances must be issued early enough to ensure that they are transmitted to the aircraft in sufficient time for it to comply with them.

10.2.2 Aircraft on flight plans specifying that the initial portion of the flight will be uncontrolled, and that the subsequent portion of the flight will be subject to air traffic control by an area control centre after the control area of origin, shall be advised to contact the area control centre in whose area controlled flight will be commenced for clearance.

10.2.3 Aircraft on flight plans specifying that the first portion of the flight will be subject to air traffic control, and

that the subsequent portion will be uncontrolled, shall normally be cleared to the point at which the controlled flight terminates.

10.2.4 An area control centre may request an adjacent area control centre to clear aircraft to a specified point during a specified period.

10.2.5 After the initial clearance has been issued to an aircraft at the point of departure, it will be the responsibility of the appropriate area control centre to issue an amended clearance whenever necessary and to issue traffic information if required.

10.2.6 During the transonic and supersonic phases of a flight, amendments to the clearance should be kept to a minimum and must take due account of the operational limitations of the aircraft in these flight phases.

10.2.7 When so requested by the pilot, an aircraft shall be cleared for cruise climb whenever traffic conditions and co-ordination procedures permit. Such clearance shall be for cruise climb either above a specified level or between specified levels.

10.2.8 When so requested by the pilot, an aircraft should, in so far as practicable, be authorized to absorb a specified period of notified terminal delay by cruising at a reduced speed for the latter portion of its flight. The specified period may be the whole or part of the notified terminal delay.

10.2.9 Where an aircraft files, at the departure aerodrome, flight plans for the various stages of flight through intermediate stops, the initial clearance limit will be the first destination aerodrome and new clearances must be issued for subsequent portions of the flight.

10.2.9.1 The flight plan for the second stage, and that for each subsequent stage, of a flight through intermediate stops will become active for ATS and SAR purposes only when the appropriate ATS unit has received notification that the aircraft has departed from the relevant departure aerodrome, except as provided for in 10.2.9.2.

10.2.9.2 By prior arrangement between air traffic control units and the operators, aircraft operating on an established schedule may be cleared through intermediate stops provided, if the proposed route of flight is through more than one control area, scheduled aircraft may be cleared through intermediate stops within other control areas only after co-ordination between the area control centres concerned.

11. Contents of air traffic control clearances

11.1 Clearances shall contain positive and concise data and shall, as far as practicable, be phrased in a standard manner.

11.2 Clearances shall contain the items specified in Part IX, 4.2.5.2.1.

12. Description of air traffic control clearances

12.1 Clearance limit

12.1.1 A clearance limit shall be described by specifying the name of the appropriate reporting point, or aerodrome, or controlled airspace boundary.

Note.— See Annex 11, 3.7.3.1 and associated Note.

12.1.2 When prior co-ordination has been effected with units under whose control the aircraft will subsequently come, or if there is reasonable assurance that it can be effected a reasonable time prior to their assumption of control, the clearance limit shall be the destination aerodrome or, if not practicable, an appropriate intermediate point, and co-ordination shall be expedited so that a clearance to the destination aerodrome may be issued as soon as possible.

12.1.3 If an aircraft has been cleared to an intermediate point in an adjacent control area, the appropriate area control centre will then be responsible for issuing, as soon as practicable, an amended clearance to the destination aerodrome.

12.1.4 When the destination aerodrome is outside a control area, the area control centre responsible for the last control area through which an aircraft will pass shall issue appropriate clearance for flight to the limit of that control area.

12.2 Route of flight

12.2.1 The route of flight shall be detailed in each clearance when deemed necessary. The phrase “cleared via flight planned route” may be used to describe any route or portion thereof, provided the route or portion thereof is identical to that filed in the flight plan and sufficient routing details are given to definitely establish the aircraft on its route. The phrases “cleared via (designation) departure” or “cleared

via (designation) arrival” may be used when standard departure or arrival routes have been established by the appropriate ATS authority and published in Aeronautical Information Publications.

12.2.2 The phrase “cleared via flight planned route” shall not be used when granting a reclearance.

12.3 Levels

12.3.1 Instructions included in clearances relating to levels shall consist of the items specified in Part IX, 4.2.5.2.2.

13. Clearances to fly maintaining own separation while in visual meteorological conditions

Note 1.— As indicated in 1.1, the provision of vertical or horizontal separation by an air traffic control unit is not applicable in respect of any specified portion of a flight cleared subject to maintaining own separation and remaining in visual meteorological conditions. It is for the flight so cleared to ensure, for the duration of the clearance, that it is not operated in such proximity to other flights as to create a collision hazard.

Note 2.— It is axiomatic that a VFR flight must remain in visual meteorological conditions at all times. Accordingly, the issuance of a clearance to a VFR flight to fly subject to maintaining own separation and remaining in visual meteorological conditions has no other object than to signify that, for the duration of the clearance, the provision of separation by air traffic control is not entailed.

13.1 When so requested by an aircraft and provided it is agreed by the pilot of the other aircraft and so authorized by the appropriate ATS authority, an area control centre may clear a controlled flight operating in airspace Classes D and E in visual meteorological conditions during the hours of daylight to fly subject to maintaining own separation to one other aircraft and remaining in visual meteorological conditions. When a controlled flight is so cleared, the following shall apply:

- a) the clearance shall be for a specified portion of the flight at or below 3 050 m (10 000 ft), during climb or descent and subject to further restrictions as and when prescribed on the basis of regional air navigation agreements;
- b) if there is a possibility that flight under visual meteorological conditions may become impracticable,

an IFR flight shall be provided with alternative instructions to be complied with in the event that flight in VMC cannot be maintained for the term of the clearance;

- c) the pilot of an IFR flight, on observing that conditions are deteriorating and considering that operation in VMC will become impossible, shall inform ATC before entering IMC and shall proceed in accordance with the alternative instructions given.

Note.— See also 14.2.

14. Essential traffic information

14.1 Essential traffic is that controlled traffic to which the provision of separation by ATC is applicable, but which, in relation to a particular controlled flight, is not separated therefrom by the minima set forth in Sections 2 to 9 inclusive of Part III, Section 3 of Part IV and 6.6 of Part VI.

Note.— Pursuant to Section 1 of Part III, but subject to certain exceptions stated therein, ATC is required to provide separation between IFR flights in airspace Classes A to E, and between IFR and VFR flights in Classes B and C. ATC is not required to provide separation between VFR flights, except within airspace Class B. Therefore, IFR or VFR flights may constitute essential traffic to IFR traffic, and IFR flights may constitute essential traffic to VFR traffic. However, a VFR flight would not constitute essential traffic to other VFR flights except within Class B airspace.

14.2 Essential traffic information shall be given to controlled flights concerned whenever they constitute essential traffic to each other.

Note.— This information will inevitably relate to controlled flights cleared subject to maintaining own separation and remaining in visual meteorological conditions.

14.3 Essential traffic information shall include:

- a) direction of flight of aircraft concerned;
- b) type of aircraft concerned;
- c) cruising level of aircraft concerned and estimated time over the reporting point nearest to where the level will be crossed.

Note.— Nothing in Section 14 is intended to prevent ATC from imparting to aircraft under its control any other information at its disposal with a view to enhancing air safety in accordance with the objectives of ATS as defined in Chapter 2 of Annex 11.

15. Clearance of a requested change in flight plan

15.1 When issuing a clearance covering a requested change in flight plan (route or cruising level) the exact nature of the change shall be included in the clearance.

15.2 If a level change is involved and more than one level is contained in the flight plan, all such levels shall be included in the clearance.

15.3 When traffic conditions will not permit clearance of a requested change in a flight plan, the words “unable to clear” shall be used. When warranted by circumstances, an alternative flight plan should be offered.

15.4 When the alternative flight plan mentioned in 15.3 is offered, the complete clearance, as amended, or that part of the clearance containing the alternative shall be included.

EMERGENCY AND COMMUNICATION FAILURE

16. Emergency procedures

16.1 General

16.1.1 The various circumstances surrounding each emergency situation preclude the establishment of exact detailed procedures to be followed. The procedures outlined herein are intended as a general guide to air traffic services personnel. Air traffic control units shall maintain full and complete co-ordination, and personnel shall use their best judgement in handling emergency situations.

Note.— To indicate that it is in a state of emergency, an aircraft equipped with an SSR transponder might operate the equipment as follows:

- a) on Mode A, Code 7700; or
- b) on Mode A, Code 7500, to indicate specifically that it is being subjected to unlawful interference.

16.2 Priority

16.2.1 An aircraft known or believed to be in a state of emergency, including being subjected to unlawful interference, shall be given priority over other aircraft.

16.3 Unlawful interference

16.3.1 Air traffic services personnel shall be prepared to recognize any indication of the occurrence of unlawful interference with an aircraft.

16.3.2 Whenever unlawful interference with an aircraft is suspected, and where automatic distinct display of SSR Mode A Code 7500 and Code 7700 is not provided, the radar controller shall attempt to verify his suspicion by setting the SSR decoder to Mode A Code 7500 and thereafter to Code 7700.

Note.— An aircraft equipped with an SSR transponder is expected to operate the transponder on Mode A Code 7500 to indicate specifically that it is the subject of unlawful interference. The aircraft may operate the transponder on Mode A Code 7700, to indicate that it is threatened by grave and imminent danger, and requires immediate assistance.

16.3.3 Whenever unlawful interference with an aircraft is known or suspected, ATS units shall promptly attend to requests by or to anticipated needs of the aircraft, including requests for relevant information relating to air navigation facilities, procedures and services along the route of flight and at any aerodrome of intended landing, and shall take such action as is necessary to expedite the conduct of all phases of the flight.

16.3.3.1 ATS units shall also:

- a) transmit, and continue to transmit, information pertinent to the safe conduct of the flight, without expecting a reply from the aircraft;
- b) monitor and plot the progress of the flight with the means available, and co-ordinate transfer of control with adjacent ATS units without requiring transmissions or other responses from the aircraft, unless communication with the aircraft remains normal;
- c) inform and continue to keep informed, appropriate ATS units, including those in adjacent flight information regions, which may be concerned with the progress of the flight;

Note.— In applying this provision, account must be taken of all the factors which may affect the progress of the flight, including fuel endurance and the possibility of sudden changes in route and destination. The objective is to provide, as far in advance as is practicable in the circumstances, each ATS unit with appropriate information as to the expected or possible penetration of the aircraft into its area of responsibility.

d) notify:

- i) the operator or his designated representative;
- ii) the appropriate rescue co-ordination centre in accordance with appropriate alerting procedures;
- iii) the designated security authority;

Note.— It is assumed that the designated security authority and/or the operator will in turn notify other parties concerned in accordance with pre-established procedures.

e) relay appropriate messages, relating to the circumstances associated with the unlawful interference, between the aircraft and designated authorities.

16.4 Emergency descent

16.4.1 Upon receipt of advice that an aircraft is making an emergency descent through other traffic, all possible action shall be taken immediately to safeguard all aircraft concerned. When deemed necessary, air traffic control units shall immediately broadcast by means of the appropriate radio aids, or if not possible, request the appropriate communications stations immediately to broadcast an emergency message.

16.5 Action by the pilot-in-command

16.5.1 It is expected that aircraft receiving such a broadcast will clear the specified areas and stand by on the appropriate radio frequency for further clearances from the air traffic control unit.

16.6 Subsequent action by the air traffic control unit

16.6.1 Immediately after such an emergency broadcast has been made the area control centre, the approach control

office, or the aerodrome control tower concerned shall forward further clearances to all aircraft involved as to additional procedures to be followed during and subsequent to the emergency descent.

17. Air-ground communication failure

17.1 Action by air traffic control units when unable to maintain two-way communication with an aircraft operating in a control area or control zone shall be as outlined in the paragraphs which follow.

17.2 As soon as it is known that two-way communication has failed, action shall be taken to ascertain whether the aircraft is able to receive transmissions from the air traffic control unit by requesting it to execute a specified manoeuvre which can be observed by radar or to transmit, if possible, a specified signal in order to indicate acknowledgement.

17.3 If the aircraft fails to indicate that it is able to receive and acknowledge transmissions, separation shall be maintained between the aircraft having the communication failure and other aircraft, based on the assumption that the aircraft will:

- a) if in visual meteorological conditions:
 - i) continue to fly in visual meteorological conditions;
 - ii) land at the nearest suitable aerodrome; and
 - iii) report its arrival by the most expeditious means to the appropriate air traffic control unit; or
- b) if in instrument meteorological conditions or when conditions are such that it does not appear feasible to complete the flight in accordance with 17.3 a):
 - i) unless otherwise prescribed on the basis of regional air navigation agreement, maintain the last assigned speed and level, or minimum flight altitude if higher, for a period of 20 minutes following the aircraft's failure to report its position over a compulsory reporting point and thereafter adjust level and speed in accordance with the filed flight plan;
 - ii) proceed according to the current flight plan route to the appropriate designated navigation aid serving the destination aerodrome and, when

required to ensure compliance with iii) below, hold over this aid until commencement of descent;

- iii) commence descent from the navigation aid specified in ii) at, or as close as possible to, the expected approach time last received and acknowledged; or, if no expected approach time has been received and acknowledged, at, or as close as possible to, the estimated time of arrival resulting from the current flight plan;
- iv) complete a normal instrument approach procedure as specified for the designated navigation aid; and
- v) land, if possible, within thirty minutes after the estimated time of arrival specified in b) or the last acknowledged expected approach time, whichever is later.

Note 1.— Provisions related to minimum levels are contained in Annex 2, 5.1.2.

Note 2.— As evidenced by the meteorological conditions prescribed therein, 17.3 a) relates to all controlled flights, whereas 17.3 b) relates only to IFR flights.

17.4 Action taken to ensure suitable separation shall cease to be based on the assumption stated in 17.3 when:

- a) it is determined that the aircraft is following a procedure differing from that in 17.3; or
- b) through the use of electronic or other aids, air traffic control units determine that action differing from that required by 17.3 may be taken without impairing safety; or
- c) positive information is received that the aircraft has landed.

17.5 As soon as it is known that two-way communication has failed, appropriate information describing the action taken by the air traffic control unit, or instructions justified by any emergency situation, shall be transmitted blind for the attention of the aircraft concerned, on the frequencies available on which the aircraft is believed to be listening, including the voice frequencies of available radio navigation or approach aids. Information shall also be given concerning:

- a) weather conditions favourable to a cloud-breaking procedure in areas where congested traffic may be avoided; and
- b) weather conditions at suitable aerodromes.

17.6 Pertinent information shall be given to other aircraft in the vicinity of the presumed position of the aircraft experiencing the failure.

17.7 As soon as it is known that an aircraft which is operating in its area of responsibility is experiencing an apparent radiocommunication failure, an air traffic services unit shall forward information concerning the radiocommunication failure to all air traffic services units concerned along the route of flight. The area control centre in whose area the destination aerodrome is located shall take steps to obtain information on the alternate aerodrome(s) and other relevant information specified in the filed flight plan, if such information is not available.

17.8 If circumstances indicate that a controlled flight experiencing a communication failure might proceed to (one of) the alternate aerodrome(s) specified in the filed flight plan, the air traffic control unit(s) serving the alternate aerodrome(s) and any other air traffic control units that might be affected by a possible diversion shall be informed of the circumstances of the failure and requested to attempt to establish communication with the aircraft at a time when the aircraft could possibly be within communication range. This shall apply particularly when, by agreement with the operator or a designated representative, a clearance has been transmitted blind to the aircraft concerned to proceed to an alternate aerodrome, or when weather conditions at the aerodrome of intended landing are such that a diversion to an alternate is considered likely.

17.9 When an air traffic control unit receives information that an aircraft, after experiencing a communication failure has re-established communication or has landed, that unit shall inform the air traffic services unit in whose area the aircraft was operating at the time the failure occurred, and other air traffic services units concerned along the route of flight, giving necessary information for the continuation of control if the aircraft is continuing in flight.

17.10 If the aircraft has not reported within thirty minutes after:

- a) the estimated time of arrival furnished by the pilot;
- b) the estimated time of arrival calculated by the area control centre; or
- c) the last acknowledged expected approach time,

whichever is latest, pertinent information concerning the aircraft shall be forwarded to aircraft operators, or their

Rules of the Air and Air Traffic Services (PANS-RAC)

designated representatives, and pilots-in-command of any aircraft concerned and normal control resumed if they so desire. It is the responsibility of the aircraft operators, or their designated representatives, and pilots-in-command of aircraft to determine whether they will resume normal operations or take other action.

OTHER IN-FLIGHT CONTINGENCIES

Note.— The texts of paragraphs 18 and 19 are reproduced from Annex 11, Chapter 2 and have the status of Standards.

18. Strayed or unidentified aircraft

Note 1.— The terms “strayed aircraft” and “unidentified aircraft” in this paragraph have the following meanings:

Strayed aircraft. An aircraft which has deviated significantly from its intended track or which reports that it is lost.

Unidentified aircraft. An aircraft which has been observed or reported to be operating in a given area but whose identity has not been established.

Note 2.— An aircraft may be considered, at the same time, as a “strayed aircraft” by one unit and as an “unidentified aircraft” by another unit.

18.1 As soon as an air traffic services unit becomes aware of a strayed aircraft, it shall take all necessary steps as outlined in 18.1.1 and 18.1.2 to assist the aircraft and to safeguard its flight.

Note.— Navigational assistance by an air traffic services unit is particularly important if the unit becomes aware of an aircraft straying, or about to stray, into an area where there is a risk of interception or other hazard to its safety.

18.1.1 If the aircraft's position is not known, the air traffic services unit shall:

- a) attempt to establish two-way communication with the aircraft, unless such communication already exists;
- b) use all available means to determine its position;
- c) inform other ATS units into whose area the aircraft may have strayed or may stray, taking into account all

the factors which may have affected the navigation of the aircraft in the circumstances;

- d) inform, in accordance with locally agreed procedures, appropriate military units and provide them with pertinent flight plan and other data concerning the strayed aircraft;
- e) request from the units referred to in c) and d) and from other aircraft in flight every assistance in establishing communication with the aircraft and determining its position.

Note.— The requirements in d) and e) apply also to ATS units informed in accordance with c).

18.1.2 When the aircraft's position is established, the air traffic services unit shall:

- a) advise the aircraft of its position and corrective action to be taken; and
- b) provide, as necessary, other ATS units and appropriate military units with relevant information concerning the strayed aircraft and any advice given to that aircraft.

18.2 As soon as an air traffic services unit becomes aware of an unidentified aircraft in its area, it shall endeavour to establish the identity of the aircraft whenever this is necessary for the provision of air traffic services or required by the appropriate military authorities in accordance with locally agreed procedures. To this end, the air traffic services unit shall take such of the following steps as are appropriate in the circumstances:

- a) attempt to establish two-way communication with the aircraft;
- b) inquire of other air traffic services units within the flight information region about the flight and request their assistance in establishing two-way communication with the aircraft;
- c) inquire of air traffic services units serving the adjacent flight information regions about the flight and request their assistance in establishing two-way communication with the aircraft;
- d) attempt to obtain information from other aircraft in the area.

18.2.1 The air traffic services unit shall, as necessary, inform the appropriate military unit as soon as the identity of the aircraft has been established.

Note.— Requirements for co-ordination between military authorities and air traffic services are specified in Annex 11, 2.16.

19. Interception of civil aircraft

19.1 As soon as an air traffic services unit learns that an aircraft is being intercepted in its area of responsibility, it shall take such of the following steps as are appropriate in the circumstances:

- a) attempt to establish two-way communication with the intercepted aircraft on any available frequency, including the emergency frequency 121.5 MHz, unless such communication already exists;
- b) inform the pilot of the intercepted aircraft of the interception;
- c) establish contact with the intercept control unit maintaining two-way communication with the intercepting aircraft and provide it with available information concerning the aircraft;
- d) relay messages between the intercepting aircraft or the intercept control unit and the intercepted aircraft, as necessary;
- e) in close co-ordination with the intercept control unit take all necessary steps to ensure the safety of the intercepted aircraft; and
- f) inform ATS units serving adjacent flight information regions if it appears that the aircraft has strayed from such adjacent flight information regions.

19.2 As soon as an air traffic services unit learns that an aircraft is being intercepted outside its area of responsibility, it shall take such of the following steps as are appropriate in the circumstances:

- a) inform the ATS unit serving the airspace in which the interception is taking place, providing this unit with available information that will assist in identifying the aircraft and requesting it to take action in accordance with 19.1;

- b) relay messages between the intercepted aircraft and the appropriate ATS unit, the intercept control unit or the intercepting aircraft.

**20. Descents by supersonic aircraft
due to solar cosmic radiation**

20.1 Air traffic control units should be prepared for the possibility that supersonic aircraft operating at levels above 15 000 m (49 000 ft) may, on rare occasions, experience a rise in solar cosmic radiation which requires them to descend to lower levels, possibly down to or below the levels being used by subsonic aircraft. When such a situation is known or

Rules of the Air and Air Traffic Services (PANS-RAC)

suspected, air traffic control units should take all possible action to safeguard all aircraft concerned, including any subsonic aircraft affected by the descent.

Note.— All supersonic aircraft in a particular portion of airspace will be affected at the same time and the event may be accompanied by a deterioration or loss of air-ground communications. It is expected that the aircraft will alert air traffic control units before the radiation reaches a critical level and will request a descent clearance when the critical level is reached. However, situations may occur in which the aircraft will need to descend without waiting for a clearance. In such cases, the aircraft are expected to advise air traffic control units, as soon as possible, of the emergency action taken.

PART IV. APPROACH CONTROL SERVICE

Note.— The following provisions are complementary to those in Part III which apply also to the provision of approach control service. See Part II, 2.2.

1. Reduction in separation minima

1.1 In addition to the circumstances mentioned in Part III, 9.1, the separation minima detailed in Parts III and IV may be reduced in the vicinity of aerodromes if

- a) adequate separation can be provided by the aerodrome controller when each aircraft is continuously visible to this controller; or
- b) each aircraft is continuously visible to pilots-in-command of the other aircraft concerned and the pilots thereof report that they can maintain their own separation, or
- c) in the case of one aircraft following another, the pilot-in-command of the succeeding aircraft reports that the other aircraft is in sight and separation can be maintained.

DEPARTING AIRCRAFT

2. General procedures for departing aircraft

2.1 When the control of traffic is based thereon, air traffic control clearances shall specify direction of take-off and turn after take-off, track to be made good before proceeding on desired heading, level to maintain before continuing climb to assigned cruising level, time, point and/or rate at which level change shall be made, and any other necessary manoeuvre consistent with safe operation of the aircraft.

Note.— Commensurate with an orderly flow of air traffic, air traffic control units should attempt to permit aircraft departing on long-distance flights to proceed on heading with as few turns or other manoeuvres as possible, and to climb to cruising level without restrictions.

2.2 Departing aircraft may be expedited by suggesting a take-off direction which is not into the wind. It is the responsibility of the pilot-in-command of an aircraft to decide between making such a take-off or waiting for normal take-off in a preferred direction.

2.3 If departures are delayed to avoid excessive holding at destination, delayed flights shall normally be cleared in an order based on their estimated time of departure, except that deviation from this order may be made to facilitate the maximum number of departures with the least average delay.

2.4 Air traffic control units should advise aircraft operators or their designated representatives when anticipated delays due to traffic conditions are likely to be substantial and in any event when they are expected to exceed 30 minutes.

3. Minimum separation between departing aircraft

Note.— The following provisions are complementary to the longitudinal separation minima specified in Part III.

3.1 One-minute separation if aircraft are to fly on tracks diverging by at least 45 degrees immediately after take-off so that lateral separation is provided (see Figure IV-1). This minimum may be reduced when aircraft are using parallel runways or when the procedure in 2.2 is adopted for operations on diverging runways which do not cross, provided instructions covering the procedure have been approved by the appropriate ATS authority and lateral separation is effected immediately after take-off.

Note 1.— Wake turbulence categorization of aircraft and longitudinal separation minima are contained in Part V, Section 16 and in Part VI, Section 7.

Note 2.— Detailed characteristics of wake vortices and their effect on aircraft are contained in the Air Traffic Services Planning Manual (Doc 9426), Part II, Section 5.

3.2 Two minutes between take-offs when the preceding aircraft is 74 km/h (40 kt) or more faster than the following aircraft and both aircraft propose to follow the same track (see Figure IV-2).

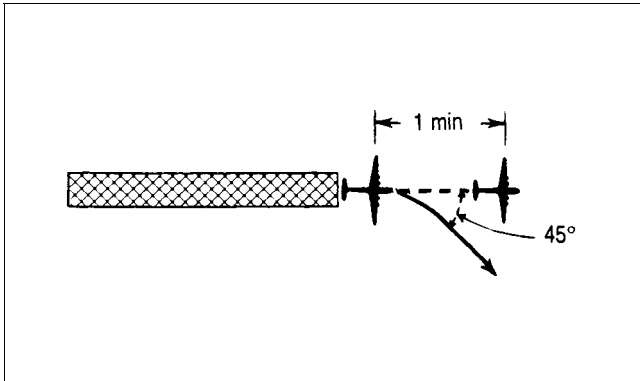

Figure IV-1 (see 3.1)

Note.— Calculations, based on TAS, of speed differentials of aircraft during climb may not be sufficiently accurate in all circumstances for determining if the procedure in 3.2 can be applied, in which case calculations based on IAS may be more suitable.

3.3 Five-minute separation while vertical separation does not exist if a departing aircraft will be flown through the level of a preceding departing aircraft and both aircraft propose to follow the same track (see Figure IV-3). Action must be taken to ensure that the five-minute separation will be maintained or increased while vertical separation does not exist.

4. Clearances for departing aircraft to climb maintaining own separation while in visual meteorological conditions

4.1 When requested by the aircraft and if so prescribed by the appropriate ATS authority a departing aircraft may be cleared to climb, subject to maintaining own separation and remaining in visual meteorological conditions until a specified time or to a specified location if reports indicate that this is possible.

Note.— See also Part III, Section 13.

5. Departing aircraft from parallel or near-parallel runways

*Note.— Guidance material is contained in the Manual on Simultaneous Operations on Parallel or Near-Parallel Instrument Runways (Doc 9643).**

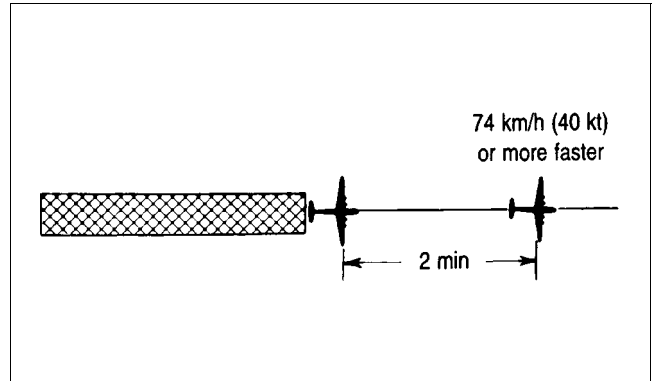

Figure IV-2 (see 3.2)

5.1 Parallel runways may be used for independent instrument departures as follows:

- both runways are used exclusively for departures (independent departures);
- one runway is used exclusively for departures while the other runway is used for a mixture of arrivals and departures (semi-mixed operation); and
- both runways are used for mixed arrivals and departures (mixed operation).

5.2 Independent parallel departures may be conducted from parallel runways provided:

- the runway centre lines are spaced by the distance specified in Annex 14, Volume I;
- the departure tracks diverge by at least 15 degrees immediately after take-off;
- suitable surveillance radar capable of identification of the aircraft within 2 km (1.0 NM) from the end of the runway is available; and
- ATS operational procedures ensure that the required track divergence is achieved.

6. Information for departing aircraft

Note.— See Part IX, 4.3 regarding flight information messages.

* In preparation.

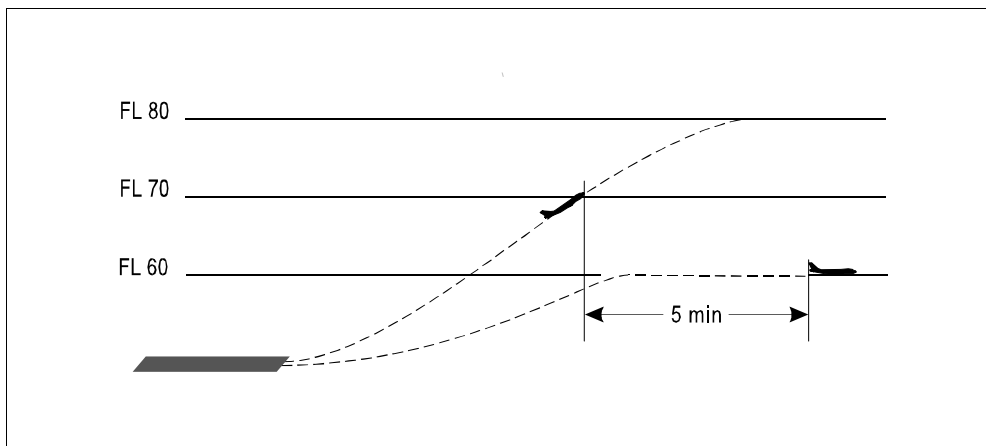

Figure IV-3 (see 8.3.3)

6.1 Information regarding significant changes in the meteorological conditions in the take-off or climb-out area, obtained by the unit providing approach control service after a departing aircraft has established communication with such unit, shall be transmitted to the aircraft without delay, except when it is known that the aircraft already has received the information.

Note.— Significant changes in this context include those relating to surface wind direction or speed, visibility, runway visual range, or air temperature (for turbine engine aircraft), and the occurrence of thunderstorm or cumulonimbus, moderate or severe turbulence, wind shear, hail, moderate or severe icing, severe squall line, freezing precipitation, severe mountain waves, sand storm, dust storm, blowing snow, tornado or waterspout.

6.2 Information regarding changes in the operational status of visual or non-visual aids essential for take-off and climb shall be transmitted without delay to a departing aircraft, except when it is known that the aircraft already has received the information.

6.3 Information regarding essential local traffic known to the controller shall be transmitted to departing aircraft without delay.

Note 1.— Essential local traffic in this context consists of any aircraft vehicle or personnel on or near the runway to be used or traffic in the take-off and climb-out area, which may constitute a collision hazard to the departing aircraft.

Note 2.— See also Part III, Section 14 and Part VI, 8.2.

ARRIVING AIRCRAFT

7. General procedures for arriving aircraft

7.1 When it becomes evident that delays in holding will be encountered by arriving aircraft, the operator or a designated representative shall be notified and kept currently informed of any changes in such expected delays, in order that diversionary action may be planned as far in advance as possible.

7.2 Arriving aircraft may be required to report when leaving or passing a reporting point, or when starting procedure turn or base turn, or to provide other information required by the controller to expedite departing aircraft.

7.3 An IFR flight shall not be cleared for an initial approach below the appropriate minimum altitude as specified by the State concerned nor to descend below that altitude unless:

- a) the pilot has reported passing an appropriate point defined by a radio aid; or
- b) the pilot reports that the aerodrome is and can be maintained in sight; or
- c) the aircraft is conducting a visual approach; or
- d) the aircraft's position has been positively determined by the use of radar.

8. Clearance to descend subject to maintaining own separation while in visual meteorological conditions

8.1 When requested by the aircraft and if so prescribed by the appropriate ATS authority an arriving aircraft may be cleared to descend subject to maintaining own separation and remaining in visual meteorological conditions if reports indicate that this is possible.

Note.— See also Part III, Section 13.

9. Visual approach

9.1 An IFR flight may be cleared to execute a visual approach provided that the pilot can maintain visual reference to the terrain and:

- a) the reported ceiling is at or above the approved initial approach level for the aircraft so cleared; or
- b) the pilot reports at the initial approach level or at any time during the instrument approach procedure that the meteorological conditions are such that with reasonable assurance a visual approach and landing can be completed.

9.2 Separation shall be provided between an aircraft cleared to execute a visual approach and other arriving and departing aircraft.

9.3 For successive visual approaches, radar or non-radar separation shall be maintained until the pilot of a succeeding aircraft reports having the preceding aircraft in sight. The aircraft shall be instructed to follow and maintain separation from the preceding aircraft. Transfer of communications should be effected at such a point or time that clearance to land or alternative instructions can be issued to the aircraft in a timely manner.

10. Instrument approach

10.1 If a pilot-in-command reports or if it is clearly apparent to the ATC unit that he or she is not familiar with an instrument approach procedure, the initial approach level, the point (in minutes from the appropriate reporting point) at which procedure turn will be started, the level at which the procedure turn shall be carried out and the final approach

Rules of the Air and Air Traffic Services (PANS-RAC)

track shall be specified, except that only the last-mentioned need be specified if the aircraft is to be cleared for a straight-in approach. The missed approach procedure shall be specified when deemed necessary.

10.2 If visual reference to terrain is established before completion of the approach procedure, the entire procedure must nevertheless be executed unless the aircraft requests and is cleared for a visual approach.

10.3 A particular approach procedure may be specified to expedite traffic. The omission of a specified approach procedure will indicate that any authorized approach may be used at the discretion of the pilot.

11. Holding

11.1 Holding and holding pattern entry shall be accomplished in accordance with procedures established by the appropriate ATS authority and published in Aeronautical Information Publications. If entry and holding procedures have not been published or if the procedures are not known to the pilot-in-command of an aircraft, the appropriate air traffic control unit shall describe the procedures to be followed.

11.2 Aircraft shall be held at a designated holding point. The required minimum vertical, lateral or longitudinal separation from other aircraft, according to the system in use at that holding point, shall be provided.

11.3 When aircraft are being held in flight, the appropriate vertical separation minima shall continue to be provided between holding aircraft and en-route aircraft while such en-route aircraft are within five minutes' flying time of the holding area, unless lateral separation exists (see Figure IV-4).

11.4 Levels at holding points shall be assigned in a manner that will facilitate clearing each aircraft to approach in its proper priority. Normally, the first aircraft to arrive over a holding point should be at the lowest level, with following aircraft at successively higher levels. However, aircraft particularly sensitive to high fuel consumption at low levels, such as supersonic aircraft, should be permitted to hold at higher levels than their order in the approach sequence indicates, without losing their order in the sequence, whenever the availability of discrete descent paths and/or radar makes it possible, subsequently, to clear the aircraft for descent through the levels occupied by other aircraft.

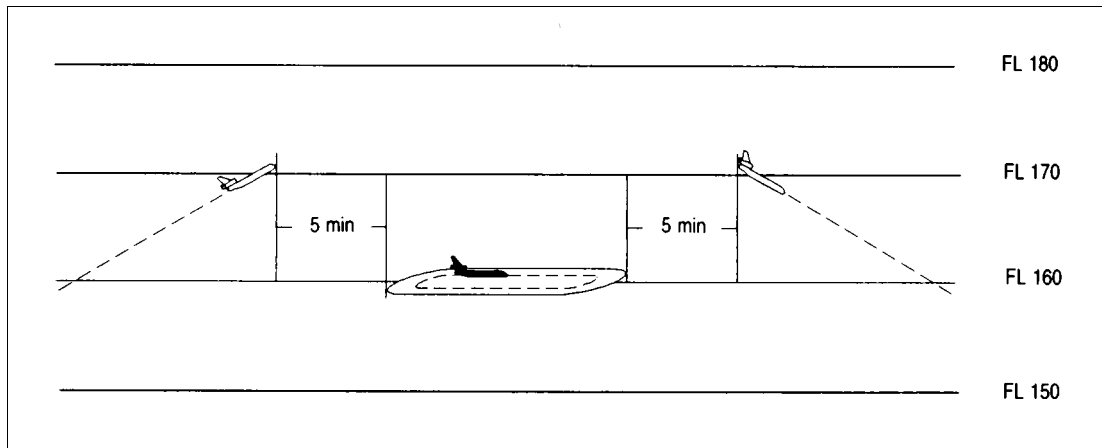

Figure IV-4 (see 11.3)

11.5 If a pilot-in-command of an aircraft advises of an inability to comply with the approach control holding or communication procedures, the alternative procedure(s) requested by the pilot-in-command should be approved if known traffic conditions permit.

12. Approach sequence

12.1 General approach procedures

The following procedures shall be applied whenever approaches are in progress:

12.1.1 The approach sequence shall be established in a manner which will facilitate arrival of the maximum number of aircraft with the least average delay. A special priority may be given to:

- a) an aircraft which anticipates being compelled to land because of factors affecting the safe operation of the aircraft (engine failure, shortage of fuel, etc.);
- b) hospital aircraft or aircraft carrying any sick or seriously injured person requiring urgent medical attention.

Note.— An aircraft which has actually encountered an emergency is handled as outlined in Part III, Section 16.

12.1.2 Succeeding aircraft shall be cleared for approach when the preceding aircraft:

- a) has reported that it is able to complete its approach without encountering instrument meteorological conditions; or
- b) is in communication with and sighted by the aerodrome control tower and reasonable assurance exists that a normal landing can be accomplished.

12.1.3 If the pilot of an aircraft in an approach sequence has indicated an intention to hold for weather improvement, or for other reasons, such action shall be approved. However, when other holding aircraft indicate intention to continue their approach-to-land and if alternative procedures involving, for instance, the use of radar are not available, the pilot desiring to hold will be cleared to an adjacent fix for holding awaiting weather change or re-routing. Alternatively, the aircraft should be given a clearance to place it at the top of the approach sequence so that other holding aircraft may be permitted to land. Co-ordination shall be effected with the area control centre, when required, to avoid conflict with the traffic under the jurisdiction of this centre. The aircraft operator, or a designated representative (if any), shall be advised of the action taken immediately after the clearance is issued, if practicable.

12.1.4 When establishing the approach sequence, an aircraft which has been authorized to absorb a specified period of notified terminal delay by cruising at a reduced speed en route, should, in so far as practicable, be credited with the time absorbed en route.

12.2 Timed approach procedures

12.2.1 Subject to approval by the appropriate ATS authority, the following procedure should be utilized as necessary to expedite the approaches of a number of arriving aircraft:

- a) a suitable point on the approach path, which shall be capable of being accurately determined by the pilot, shall be specified, to serve as a check point in timing successive approaches;
- b) aircraft shall be given a time at which to pass the specified point inbound, which time shall be determined with the aim of achieving the desired interval between successive landings on the runway while respecting the applicable separation minima at all times, including the period of runway occupancy.

Note 1.— Guidance material on factors to be taken into account when determining separation for timed approaches is contained in the Air Traffic Services Planning Manual (Doc 9426).

Note 2.— Wake turbulence categorization of aircraft and longitudinal separation minima are contained in Part V, Section 16.

Note 3.— Detailed characteristics of wake vortices and their effect on aircraft are contained in the Air Traffic Services Planning Manual (Doc 9426), Part II, Section 5.

12.2.2 The time at which aircraft should pass the specified point shall be determined by the unit providing approach control service and notified to the aircraft sufficiently in advance to permit the pilot to arrange the flight path accordingly.

12.2.2.1 Each aircraft in the approach sequence shall be cleared to pass the specified point inbound at the previously notified time, or any revision thereof, after the preceding aircraft has reported passing the point inbound.

13. Arriving aircraft to parallel or near-parallel runways

*Note.— Guidance material is contained in the Manual on Simultaneous Operations on Parallel or Near-Parallel Instrument Runways (Doc 9643).**

13.1 Parallel runways may be used for simultaneous instrument operations for:

- a) independent parallel approaches; or
- b) dependent parallel approaches; or
- c) segregated parallel operations.

13.2 Independent parallel approaches

13.2.1 Independent parallel approaches may be conducted to parallel runways provided that:

- a) the runway centre lines are spaced by the distance specified in Annex 14, Volume I; and
 - 1) where runway centre lines are spaced by less than 1 310 m but not less than 1 035 m, suitable secondary surveillance radar (SSR) equipment, with a minimum azimuth accuracy of 0.06 degrees (one sigma), an update period of 2.5 seconds or less and a high resolution display providing position prediction and deviation alert, is available; or
 - 2) where runway centre lines are spaced by less than 1 525 m but not less than 1 310 m, SSR equipment with specifications other than the foregoing may be applied when it is determined that the safety of aircraft operation would not be adversely affected; or
 - 3) where runway centre lines are spaced by 1 525 m or more, suitable surveillance radar with a minimum azimuth accuracy of 0.3 degrees (one sigma) and update period of 5 seconds or less is available;
- b) instrument landing system (ILS) and/or microwave landing system (MLS) approaches are being conducted on both runways;
- c) the aircraft are making straight-in approaches;
- d) the missed approach track for one approach diverges by at least 30 degrees from the missed approach track of the adjacent approach;

* In preparation.

- e) an obstacle survey and evaluation is completed, as appropriate, for the areas adjacent to the final approach segments;
- f) aircraft are advised of the runway identification and ILS localizer or MLS frequency;
- g) radar vectoring is used to intercept the ILS localizer course or the MLS final approach track;
- h) a no-transgression zone (NTZ) at least 610 m wide is established equidistant between extended runway centre lines and is depicted on the radar display;
- i) separate radar controllers monitor the approaches to each runway and ensure that when the 300 m (1 000 ft) vertical separation is reduced:
 - 1) aircraft do not penetrate the depicted NTZ; and
 - 2) the applicable minimum longitudinal separation between aircraft on the same ILS localizer course or MLS final approach track is maintained; and
- j) if no dedicated radio channels are available for the radar controllers to control the aircraft until landing:
 - 1) transfer of communication of aircraft to the respective aerodrome controller's frequency is effected before the higher of two aircraft on adjacent final approach tracks intercepts the ILS glide path or the specified MLS elevation angle; and
 - 2) the radar controllers monitoring the approaches to each runway are provided with the capability to override transmissions of aerodrome control on the respective radio channels for each arrival flow.

13.2.2 As early as practicable after an aircraft has established communication with approach control, the aircraft shall be advised that independent parallel approaches are in force. This information may be provided through the automatic terminal information service (ATIS) broadcasts. In addition, the aircraft shall be advised of the runway identification and the ILS localizer or MLS frequency to be used.

13.2.3 When vectoring to intercept the ILS localizer course or MLS final approach track, the final vector shall be such as to enable the aircraft to intercept the ILS localizer course or MLS final approach track at an angle not greater

than 30 degrees and to provide at least 2 km (1.0 NM) straight and level flight prior to ILS localizer course or MLS final approach track intercept. The vector shall also be such as to enable the aircraft to be established on the ILS localizer course or MLS final approach track in level flight for at least 3.7 km (2.0 NM) prior to intercepting the ILS glide path or specified MLS elevation angle.

13.2.4 A minimum of 300 m (1 000 ft) vertical or a minimum of 5.6 km (3.0 NM) radar separation shall be provided until aircraft are established:

- a) inbound on the ILS localizer course and/or MLS final approach track; and
- b) within the normal operating zone (NOZ).

A minimum of 5.6 km (3.0 NM) radar separation shall be provided between aircraft on the same ILS localizer course or MLS final approach track unless increased longitudinal separation is required due to wake turbulence.

Note 1.— See Part VI, 7.4.4.

Note 2.— An aircraft established on an ILS localizer course or MLS final approach track is separated from another aircraft established on an adjacent parallel ILS localizer course or MLS final approach track provided neither aircraft penetrates the depicted NTZ.

13.2.5 When assigning the final heading to intercept the ILS localizer course or MLS final approach track, the aircraft shall be advised of:

- a) its position relative to a fix on the ILS localizer course or MLS final approach track;
- b) the altitude to be maintained until established on the ILS localizer course or MLS final approach track to the ILS glide path or specified MLS elevation angle intercept point; and
- c) if required, clearance for the appropriate ILS or MLS approach.

13.2.6 All approaches regardless of weather conditions shall be radar-monitored. Control instructions and information necessary to ensure separation between aircraft and to ensure aircraft do not enter the NTZ shall be issued.

Note 1.— The primary responsibility for navigation on the ILS localizer course and/or MLS final approach track rests

with the pilot. Control instructions and information are therefore issued only to ensure separation between aircraft and to ensure that aircraft do not penetrate the NTZ. Pilots are not required to acknowledge those transmissions unless specifically requested to do so.

Note 2.— For the purpose of ensuring an aircraft does not penetrate the NTZ, the aircraft is considered to be the centre of its radar position symbol. The provisions regarding radar separation also apply.

13.2.7 When an aircraft is observed to overshoot the turn-on or to continue on a track which will penetrate the NTZ, the aircraft shall be instructed to return immediately to the correct track.

13.2.8 When an aircraft is observed penetrating the NTZ, the aircraft on the adjacent ILS localizer course or MLS final approach track shall be issued with appropriate heading and altitude instructions in order to avoid the deviating aircraft.

13.2.9 Radar monitoring shall not be terminated until:

- a) visual separation is applied; or
- b) the aircraft has landed, or in case of a missed approach, is at least 2 km (1.0 NM) beyond the departure end of the runway and adequate separation with any other traffic is established.

Note.— There is no requirement to advise the aircraft that radar monitoring is terminated.

13.3 Suspension of independent parallel approaches to closely-spaced parallel runways

13.3.1 Independent parallel approaches to parallel runways spaced by less than 1 525 m but not less than 1 035 m between their centre lines shall be suspended under certain weather conditions, as prescribed by the appropriate ATS authority, including windshear, turbulence, downdrafts, crosswind and severe weather such as thunderstorms, which might otherwise increase ILS localizer course and/or MLS final approach track deviations to the extent that an unacceptable level of deviation alerts would be generated.

*Note.— Guidance material relating to weather conditions is contained in the Manual on Simultaneous Operations on Parallel or Near-Parallel Instrument Runways (Doc 9643).**

Rules of the Air and Air Traffic Services (PANS-RAC)

13.4 Dependent parallel approaches

13.4.1 Dependent parallel approaches may be conducted to parallel runways provided:

- a) the runway centre lines are spaced by the distance specified in Annex 14, Volume I;
- b) the aircraft are making straight-in approaches;
- c) suitable surveillance radar with a minimum azimuth accuracy of 0.3 degrees (one sigma) and update period of 5 seconds or less is available;
- d) ILS and/or MLS approaches are being conducted on both runways;
- e) aircraft are advised that approaches are in use to both runways (this information may be provided through the ATIS);
- f) the missed approach track for one approach diverges by at least 30 degrees from the missed approach track of the adjacent approach; and
- g) approach control has an override capability to aerodrome control.

13.4.2 A minimum of 300 m (1 000 ft) vertical or a minimum of 5.6 km (3.0 NM) radar separation shall be provided between aircraft during turn-on to parallel ILS localizer courses and/or MLS final approach tracks.

13.4.3 The minimum radar separation to be provided between aircraft established on the ILS localizer course and/or MLS final approach track shall be:

- a) 5.6 km (3.0 NM) between aircraft on the same ILS localizer course or MLS final approach track unless increased longitudinal separation is required due to wake turbulence; and
- b) 3.7 km (2.0 NM) between successive aircraft on adjacent ILS localizer courses or MLS final approach tracks.

13.5 Segregated parallel operations

13.5.1 Segregated parallel operations may be conducted on parallel runways provided:

* In preparation.

- a) the runway centre lines are spaced by the distance specified in Annex 14, Volume I; and
- b) the nominal departure track diverges immediately after take-off by at least 30 degrees from the missed approach track of the adjacent approach (see Figure IV-5).

13.5.1.1 The minimum distance between parallel runway centre lines for segregated parallel operations may be decreased by 30 m for each 150 m that the arrival runway is staggered toward the arriving aircraft, to a minimum of 300 m (see Figure IV-6) and should be increased by 30 m for each 150 m that the arrival runway is staggered away from the arriving aircraft (see Figure IV-7).

13.5.2 The following types of approaches may be conducted in segregated parallel operations provided suitable surveillance radar and the appropriate ground facilities conform to the standard necessary for the specific type of approach:

- a) ILS and/or MLS precision;
- b) radar; and
- c) visual.

*Note.— Guidance material is contained in the Manual on Simultaneous Operations on Parallel or Near-Parallel Instrument Runways (Doc 9643).**

* In preparation.

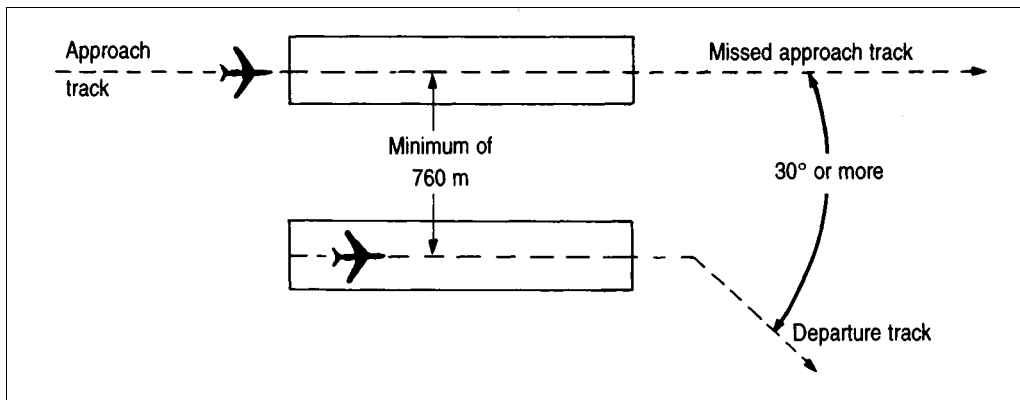

Figure IV-5 (see 13.5.1 b))

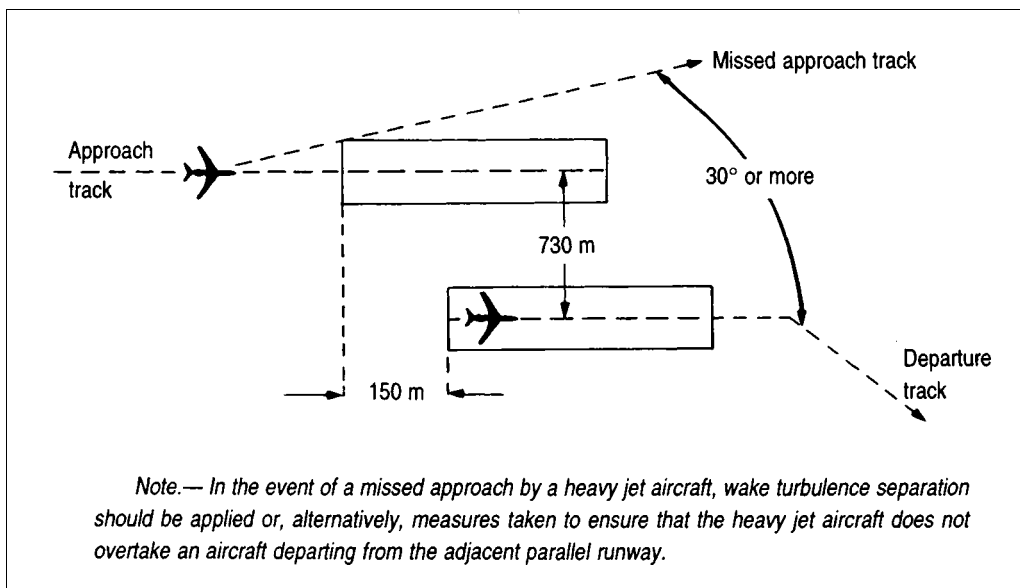

Figure IV-6 (see 13.5.1.1)

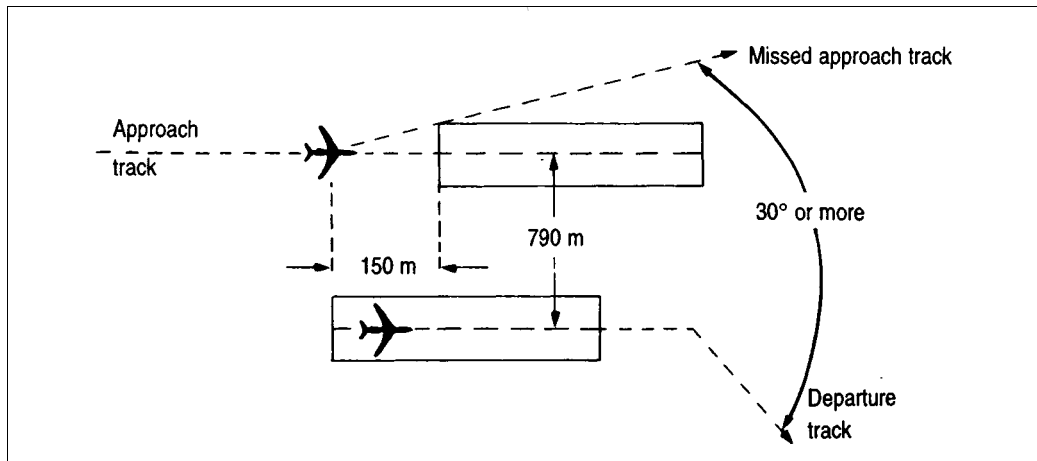

Figure IV-7 (see 13.5.1.1)

14. Expected approach time

14.1 An expected approach time shall be determined for an arriving aircraft that will be subjected to a delay, and shall be transmitted to the aircraft as soon as practicable and preferably not later than at the commencement of its initial descent from cruising level. In the case of aircraft particularly sensitive to high fuel consumption at low levels, an expected approach time should, whenever possible, be transmitted to the aircraft early enough before its intended descent time to enable the pilot to choose the method of absorbing the delay and to request a change in the flight plan if the choice is to reduce speed en route. A revised expected approach time shall be transmitted to the aircraft without delay whenever it differs from that previously transmitted by 5 minutes or more, or such lesser period of time as has been established by the appropriate ATS authority or agreed between the ATS units concerned.

14.2 An expected approach time shall be transmitted to the aircraft by the most expeditious means whenever it is anticipated that the aircraft will be required to hold for thirty minutes or more.

14.3 The holding point to which an expected approach time relates shall be identified together with the expected approach time whenever circumstances are such that this would not otherwise be evident to the pilot.

15. Information for arriving aircraft

Note.— See Part IX, 4.3 regarding flight information messages.

15.1 As early as practicable after an aircraft has established communication with the unit providing approach control service, the following elements of information, in the order listed, shall be transmitted to the aircraft, with the exception of such elements which it is known the aircraft has already received:

- a) runway-in-use;
- b) meteorological information, as follows:
 - 1) surface wind direction and speed, including significant variations;
 - 2) visibility and, when applicable, runway visual range (RVR);
 - 3) present weather;
 - 4) cloud below 1 500 m (5 000 ft) or below the highest minimum sector altitude, whichever is greater; cumulonimbus; if the sky is obscured, vertical visibility when available;
 - 5) air temperature;
 - 6) dew point temperature, inclusion determined on the basis of regional air navigation agreement;
 - 7) altimeter setting(s);
 - 8) any available information on significant meteorological phenomena in the approach area; and
 - 9) trend-type landing forecast, when available.

Note.— The meteorological information listed above is identical to that required in ATIS broadcasts for arriving aircraft as specified in Annex 11, 4.3.6 j) to r) and is to be extracted from meteorological reports disseminated locally at the aerodrome, in accordance with Part IX, 4.3.2.2 and 4.3.2.3.

- c) current runway surface conditions, in case of precipitants or other temporary hazards;
- d) changes in the operational status of visual and non-visual aids essential for approach and landing.

15.2 In applying the provisions in 13.1, it should be recognized that information published by NOTAM or disseminated by other means may not have been received by the aircraft prior to departure or during en-route flight.

15.3 At the commencement of final approach, the following information shall be transmitted to aircraft:

- a) significant changes in the mean surface wind direction and speed;

Note.— Significant changes are specified in Annex 3, Chapter 4. However, if the controller possesses wind information in the form of components, the significant changes are:

- Mean head-wind component: 19 km/h (10 kt)
- Mean tail-wind component: 4 km/h (2 kt)
- Mean cross-wind component: 9 km/h (5 kt)

- b) the latest information, if any, on wind shear and/or turbulence in the final approach area;
- c) the current visibility representative of the direction of approach and landing or, when provided, the current runway visual range value(s) and the trend, if practicable, supplemented by slant visual range value(s), if provided.

15.4 During final approach, the following information shall be transmitted without delay:

- a) the sudden occurrence of hazards (e.g. unauthorized traffic on the runway);
- b) significant variations in the current surface wind, expressed in terms of minimum and maximum values;
- c) significant changes in runway surface conditions;

- d) changes in the operational status of required visual or non-visual aids;
- e) changes in observed RVR value(s), in accordance with the reported scale in use, or changes in the visibility representative of the direction of approach and landing.

16. Separation of departing aircraft from arriving aircraft

Except as otherwise prescribed by the appropriate ATS authority, the following separation shall be applied when take-off clearance is based on the position of an arriving aircraft:

16.1 If an arriving aircraft is making a complete instrument approach, a departing aircraft may take off:

- a) in any direction until an arriving aircraft has started its procedure turn or base turn leading to final approach;
- b) in a direction which is different by at least 45 degrees from the reciprocal of the direction of approach after the arriving aircraft has started procedure turn or base turn leading to final approach, provided that the take-off will be made at least three minutes before the arriving aircraft is estimated to be over the beginning of the instrument runway (see Figure IV-8).

16.2 If an arriving aircraft is making a straight-in approach, a departing aircraft may take off:

- a) in any direction until five minutes before the arriving aircraft is estimated to be over the instrument runway;
- b) in a direction which is different by at least 45 degrees from the reciprocal of the direction of approach of the arriving aircraft:
 - i) until three minutes before the arriving aircraft is estimated to be over the beginning of the instrument runway (see Figure IV-8), or
 - ii) before the arriving aircraft crosses a designated fix on the approach track; the location of such fix to be determined by the appropriate ATS authority after consultation with the operators.

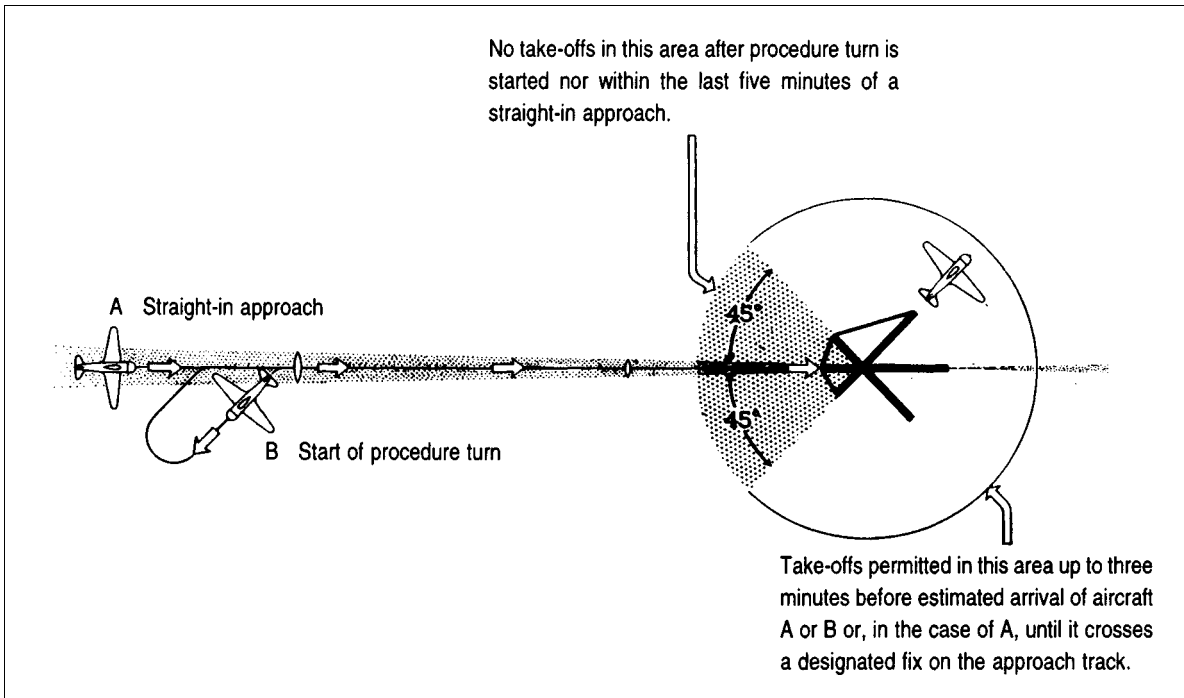

Figure IV-8 (see 16.1 and 16.2)

PART V. AERODROME CONTROL SERVICE

Note.— This Part also includes procedures for the operation of aeronautical ground lights (see Section 6).

FUNCTIONS OF AERODROME CONTROL TOWERS

1. General

Aerodrome control towers shall issue information and clearances to aircraft under their control to achieve a safe, orderly and expeditious flow of air traffic on and in the vicinity of an aerodrome with the object of preventing collision(s) between:

- a) aircraft flying in the aerodrome traffic circuits around an aerodrome;
- b) aircraft operating on the manoeuvring area;
- c) aircraft landing and taking off;
- d) aircraft and vehicles operating on the manoeuvring area;
- e) aircraft on the manoeuvring area and obstructions on that area.

2. Alerting service provided by aerodrome control towers

2.1 Aerodrome control towers are also responsible for alerting the safety services and shall immediately report any failure or irregularity of operation in any apparatus, light or other device established at an aerodrome for the guidance of aerodrome traffic and pilots-in-command of aircraft.

2.2 Aircraft which fail to report after having been handed over to an aerodrome control tower, or, having once reported, cease radio contact and in either case fail to land five minutes after the expected landing time, shall be reported to the area control centre or flight information centre.

3. Suspension of visual flight rules operations by aerodrome control towers

3.1 Any or all visual flight rules operations on and in the vicinity of an aerodrome may be suspended by any of the following units, persons or authorities whenever safety requires such action:

- a) the area control centre within whose control area the aerodrome is located;
- b) the aerodrome controller on duty;
- c) the appropriate ATS authority.

3.2 All such suspensions of visual flight rules operations shall be accomplished through or notified to the aerodrome control tower.

3.3 The following procedures shall be observed by the aerodrome control tower whenever visual flight rules operations are suspended:

- a) hold all departures other than those which file an instrument flight rules flight plan and obtain approval thereof from the area control centre;
- b) recall all local flights operating under visual flight rules or obtain approval for special VFR operations;
- c) notify the area control centre of the action taken;
- d) notify all operators, or their designated representatives, of the reason for taking such action if necessary or requested.

TRAFFIC AND TAXI CIRCUITS

4. Critical positions of aircraft in the aerodrome traffic and taxi circuits

4.1 Aerodrome controllers shall maintain a continuous watch on all visible flight operations on and in the vicinity of an aerodrome, including aircraft, vehicles and personnel on

the manoeuvring area, and shall control such traffic in accordance with the procedures set forth herein and all applicable traffic rules. If there are other aerodromes within a control zone, traffic at all aerodromes within such a zone shall be co-ordinated so that traffic circuits do not conflict.

4.2 The following positions of aircraft in the traffic and taxi circuits are the positions where the aircraft normally receive aerodrome control tower clearances, whether these are given by light signals or radio. The aircraft should be watched closely as they approach these positions so that proper clearances may be issued without delay. Where practicable, all clearances should be issued without waiting for the aircraft to initiate the call.

Position 1. Aircraft initiates call to taxi for departing flight. Runway-in-use information and taxi clearances given.

Position 2. If there is conflicting traffic, the departing aircraft will be held at this point. Motors of the aircraft will normally be run up here.

Position 3. Take-off clearance is issued here, if not practicable at position 2.

Position 4. Clearance to land is issued here.

Position 5. Clearance to taxi to hangar line or parking area is issued here.

Position 6. Parking information issued here if necessary.

Note.— See Figures V-1 and V-2.

4.3 A frequency change should not be issued to single-pilot helicopters during emergency situations, air-taxiing, or low-level flight. Whenever possible, control instructions from the next ATS unit should be relayed as necessary until the pilot is able to change frequency.

Note.— Most light helicopters are flown by one pilot and require the constant use of both hands and feet to maintain control during low-altitude/low-level flight. Although flight control friction devices assist the pilot, changing frequency near the ground could result in inadvertent ground contact and consequent loss of control.

5. Selection of runway-in-use

5.1 The term “runway-in-use” shall be used to indicate the runway that at a particular time is considered by a unit

Rules of the Air and Air Traffic Services (PANS-RAC)

providing aerodrome control service to be the most suitable for use by the types of aircraft expected to land or take off at the aerodrome.

5.2 Normally, an aircraft will land and take off into wind unless safety, the runway configuration, or air traffic conditions determine that a different direction is preferable. In selecting the runway-in-use, however, the unit providing aerodrome control service shall take into consideration, besides surface wind speed and direction, other relevant factors such as the aerodrome traffic circuits, the length of runways, and the approach and landing aids available.

5.3 If the runway-in-use is not considered suitable for the operation involved the pilot-in-command may request permission to use another runway.

AERONAUTICAL GROUND LIGHTS

6. Operation

Note.— The procedures in this Section apply to all aerodromes, whether or not aerodrome control service is provided. In addition the procedures in 6.1.1 apply to all aeronautical ground lights, whether or not they are on or in the vicinity of an aerodrome.

6.1 General

6.1.1 All aeronautical ground lights shall be operated, except as provided in 6.1.2 and 6.2:

- a) continuously during the hours of darkness or during the time the centre of the sun's disc is more than 6 degrees below the horizon, whichever requires the longer period of operation, unless otherwise provided hereafter or otherwise required for the control of air traffic;
- b) at any other time when their use, based on weather conditions, is considered desirable for the safety of air traffic.

6.1.2 Lights on and in the vicinity of aerodromes that are not intended for en-route navigation purposes may be turned off, subject to further provisions hereafter, if no likelihood of either regular or emergency operation exists, provided that they can be again brought into operation at least one hour before the expected arrival of an aircraft.

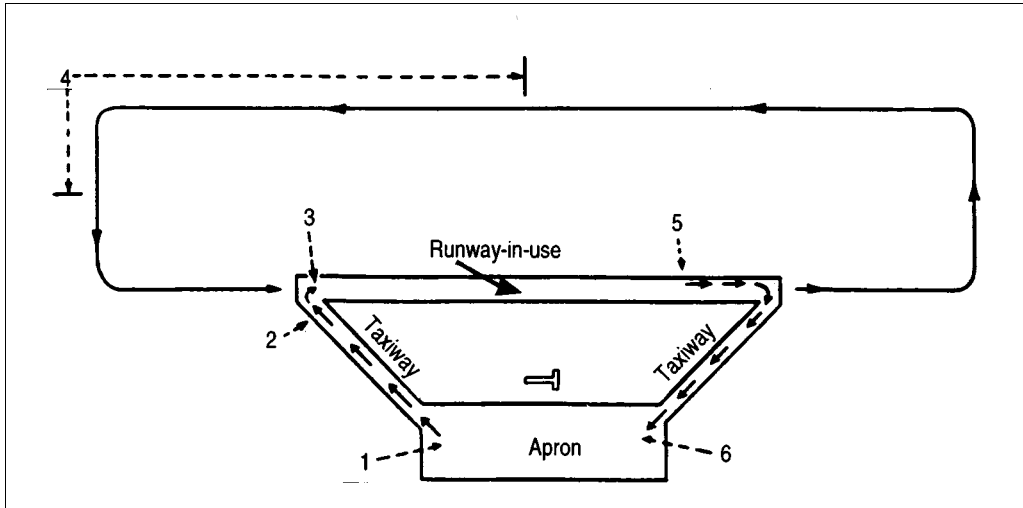

Fig. V-1. Critical positions of aircraft from an aerodrome control tower viewpoint (see 4.2)

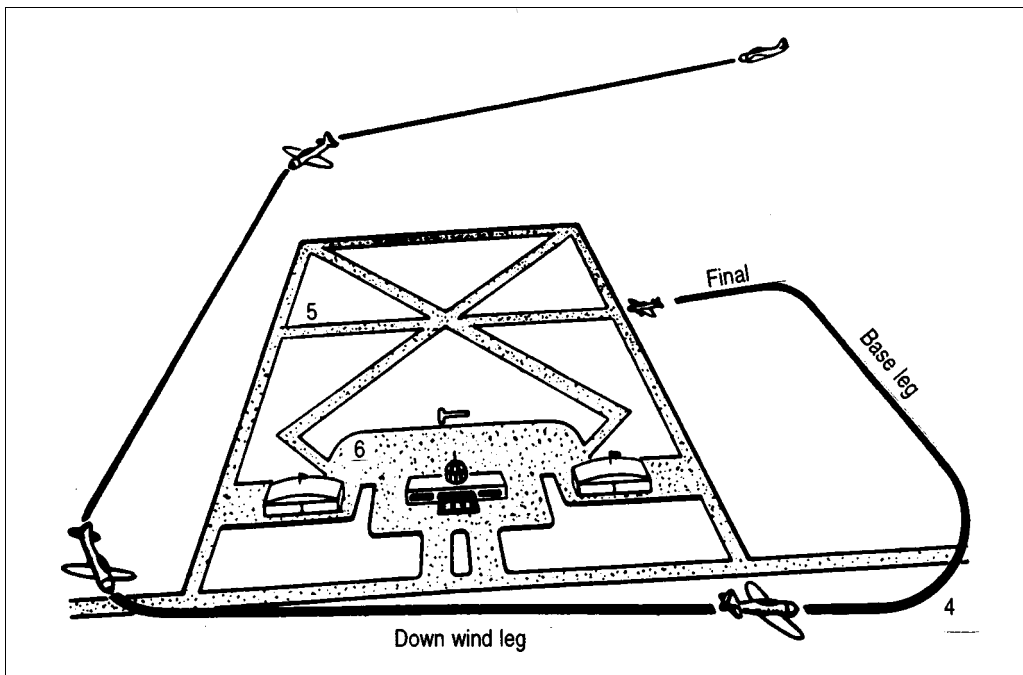

Fig. V-2. Typical elements of traffic circuit (see 4.2)

6.1.3 At aerodromes equipped with lights of variable intensity a table of intensity settings, based on conditions of visibility and ambient light, should be provided for the guidance of air traffic controllers in effecting adjustment of these lights to suit the prevailing conditions. When so requested by an aircraft, further adjustment of the intensity may be made whenever possible.

6.2 Approach lighting

Note.— Approach lighting includes such lights as simple approach lighting systems, precision approach lighting systems, visual approach slope indicator systems, circling guidance lights, approach light beacons and runway alignment indicators.

6.2.1 In addition to 6.1.1 approach lighting shall also be operated:

- a) by day when requested by an approaching aircraft;
- b) when the associated runway lighting is operated.

6.2.2 The lights of a visual approach slope indicator system shall be operated during the hours of daylight as well as of darkness and irrespective of the visibility conditions when the associated runway is being used.

6.3 Runway lighting

Note.— Runway lighting includes such lights as edge, threshold, centre line, end, touchdown zone and wing bar lights.

6.3.1 Runway lighting shall not be operated if that runway is not in use for landing, take-off or taxiing purposes.

6.3.2 If runway lighting is not operated continuously, lighting following a take-off shall be provided as specified below:

- a) at aerodromes where air traffic control service is provided and where lights are centrally controlled, the lights of one runway shall remain lighted after take-off as long as is considered necessary for the return of the aircraft due to an emergency occurring during or immediately after take-off;
- b) at aerodromes without air traffic control service or without centrally controlled lights, the lights of one

Rules of the Air and Air Traffic Services (PANS-RAC)

runway shall remain lighted until such time as would normally be required to reactivate the lights in the likelihood of the departing aircraft returning for an emergency landing, and in any case not less than fifteen minutes after take-off.

Note.— Where obstacle lighting is operated simultaneously with runway lighting as provided in 6.7.1, particular care should be taken to ensure that it is not turned off until no longer required by the aircraft.

6.4 Stopway lighting

6.4.1 Stopway lights shall be operated whenever the associated runway lights are operated.

6.5 Taxiway lighting

Note.— Taxiway lighting includes such lights as edge lights, centre line lights, stop bars and clearance bars.

6.5.1 Taxiway lighting shall be turned on in such order that a continuous indication of the taxi path is presented to taxiing aircraft. Taxiway lighting or any portion thereof may be turned off when no longer needed by the taxiing aircraft.

6.6 Stop bars

6.6.1 Stop bars shall be switched on to indicate that all traffic shall stop, and switched off to indicate that traffic may proceed.

6.7 Obstacle lighting

Note.— Obstacle lighting includes such lights as obstacle and unserviceability lights and hazard beacons.

6.7.1 Obstacle lighting associated with the approach to or departure from a runway or channel, where the obstacle does not project through the inner horizontal surface, as described in Annex 14, Volume I, Chapter 6, may be turned off and on simultaneously with the runway or channel lights.

6.7.2 Unserviceability lights may not be turned off as permitted under 6.1.2 while the aerodrome is open.

6.8 Monitoring of visual aids

6.8.1 Aerodrome controllers shall make use of automatic monitoring facilities, when provided, to ascertain whether the lighting is in good order and functioning according to selection.

6.8.2 In the absence of an automatic monitoring system or to supplement such a system, the aerodrome controller shall visually observe such lighting as can be seen from the aerodrome control tower and use information from other sources such as visual inspections or reports from aircraft to maintain awareness of the operational status of the visual aids.

6.8.3 On receipt of information indicating a lighting fault, the aerodrome controller shall take such action as is warranted to safeguard any affected aircraft or vehicles, and initiate action to have the fault rectified.

INFORMATION TO AIRCRAFT BY AERODROME CONTROL TOWERS

7. Information related to the operation of aircraft

Note.— See Part IX, 4.3 regarding flight information messages.

7.1 When so requested by the pilot prior to engine start, an expected take-off time should be given, unless engine start time procedures are employed.

7.2 Prior to taxiing for take-off, aircraft shall be advised of the following elements of information, in the order listed, with the exception of such elements which it is known the aircraft has already received:

- a) the runway to be used;
- b) the current surface wind direction and speed, including significant variations;
- c) the QNH altimeter setting and, either on a regular basis in accordance with local arrangements or if so requested by the aircraft, the QFE altimeter setting;
- d) the air temperature for the runway to be used, in the case of turbine-engined aircraft;

- e) the current visibility representative of the direction of take-off and initial climb, if less than 10 km, or, when provided, the current RVR value(s) for the runway to be used;

- f) the correct time.

7.3 Prior to take-off aircraft shall be advised of:

- a) any significant changes in the surface wind direction and speed, the air temperature, and the visibility or RVR value(s) given in accordance with 7.2;
- b) significant meteorological conditions in the take-off and climb-out area, except when it is known that the information has already been received by the aircraft.

Note.— Significant meteorological conditions in this context include the occurrence or expected occurrence of cumulonimbus or thunderstorm, moderate or severe turbulence, wind shear, hail, moderate or severe icing, severe squall line, freezing precipitation, severe mountain waves, sand storm, dust storm, blowing snow, tornado or waterspout in the take-off and climb-out area.

7.4 Prior to entering the traffic circuit an aircraft shall be provided with the following elements of information, in the order listed, with the exception of such elements which it is known the aircraft has already received:

- a) the runway to be used;
- b) the mean surface wind direction and speed and significant variations therefrom;
- c) the QNH altimeter setting and, either on a regular basis in accordance with local arrangements or, if so requested by the aircraft, the QFE altimeter setting.

7.5 When operating under visual meteorological conditions, it is the responsibility of the pilot-in-command of an aircraft to avoid collision with other aircraft. However, due to the restricted space on and around manoeuvring areas, it is often essential that traffic information be issued to aid the pilot-in-command of an aircraft to avoid collision.

7.6 Essential local traffic shall be considered to consist of any aircraft, vehicle or personnel on or near the manoeuvring area or traffic operating in the vicinity of the aerodrome, which may constitute a hazard to the aircraft concerned.

7.7 Information on essential local traffic shall be issued either directly or through the unit providing approach control service when, in the judgment of the aerodrome controller, such information is necessary in the interests of safety, or when requested by aircraft.

7.8 Essential local traffic shall be so described as to facilitate recognition.

7.9 Aerodrome controllers shall, whenever practicable, advise aircraft of the expected occurrence of hazards caused by turbulent wake.

Note.— Occurrence of turbulent wake hazards cannot be accurately predicted and aerodrome controllers cannot assume responsibility for the issuance of advice on such hazards at all times, nor for its accuracy. Information on hazards due to wake vortices is contained in the Air Traffic Services Planning Manual (Doc 9426), Part II, Section 5.

7.10 In issuing clearances or instructions, air traffic controllers should take into account the hazards caused by jet blast and propeller slipstream to taxiing aircraft, to aircraft taking off or landing, particularly when intersecting runways are being used, and to vehicles and personnel operating on the aerodrome.

Note.— Jet blast and propeller slipstream can produce localized wind velocities of sufficient strength to cause damage to other aircraft, vehicles and personnel operating within the affected area.

8. Information on aerodrome conditions

Note.— See Part IX, 4.3.4 regarding messages containing information on aerodrome conditions.

8.1 Essential information on aerodrome conditions is information necessary to safety in the operation of aircraft, which pertains to the movement area or any facilities usually associated therewith. For example, construction work on a taxi strip not connected to the runway-in-use would not be essential information to any aircraft except one that might be taxied in the vicinity of the construction work. As another example, if all traffic must be confined to runways, that fact should be considered as essential aerodrome information to any aircraft not familiar with the aerodrome.

8.2 Essential information on aerodrome conditions shall include information relating to the following:

Rules of the Air and Air Traffic Services (PANS-RAC)

- a) construction or maintenance work on, or immediately adjacent to the movement area;
- b) rough or broken surfaces on a runway, a taxiway or an apron, whether marked or not;
- c) snow, slush or ice on a runway, a taxiway or an apron;
- d) water on a runway, a taxiway or an apron;
- e) snow banks or drifts adjacent to a runway, a taxiway or an apron;
- f) other temporary hazards, including parked aircraft and birds on the ground or in the air;
- g) failure or irregular operation of part or all of the aerodrome lighting system;
- h) any other pertinent information.

Note.— See Figure V-3.

8.3 Essential information on aerodrome conditions shall be given to every aircraft, except when it is known that the aircraft already has received all or part of the information from other sources. The information shall be given in sufficient time for the aircraft to make proper use of it, and the hazards shall be identified as distinctly as possible.

Note.— “Other sources” include NOTAM, ATIS broadcasts, and the display of suitable signals.

CONTROL OF AERODROME TRAFFIC

9. Order of priority for arriving and departing aircraft

9.1 An aircraft landing or in the final stages of an approach to land shall normally have priority over an aircraft intending to depart.

9.2 Departures shall normally be cleared in the order in which they are ready for take-off, except that deviations may be made from this order of priority to facilitate the maximum number of departures with the least average delay.

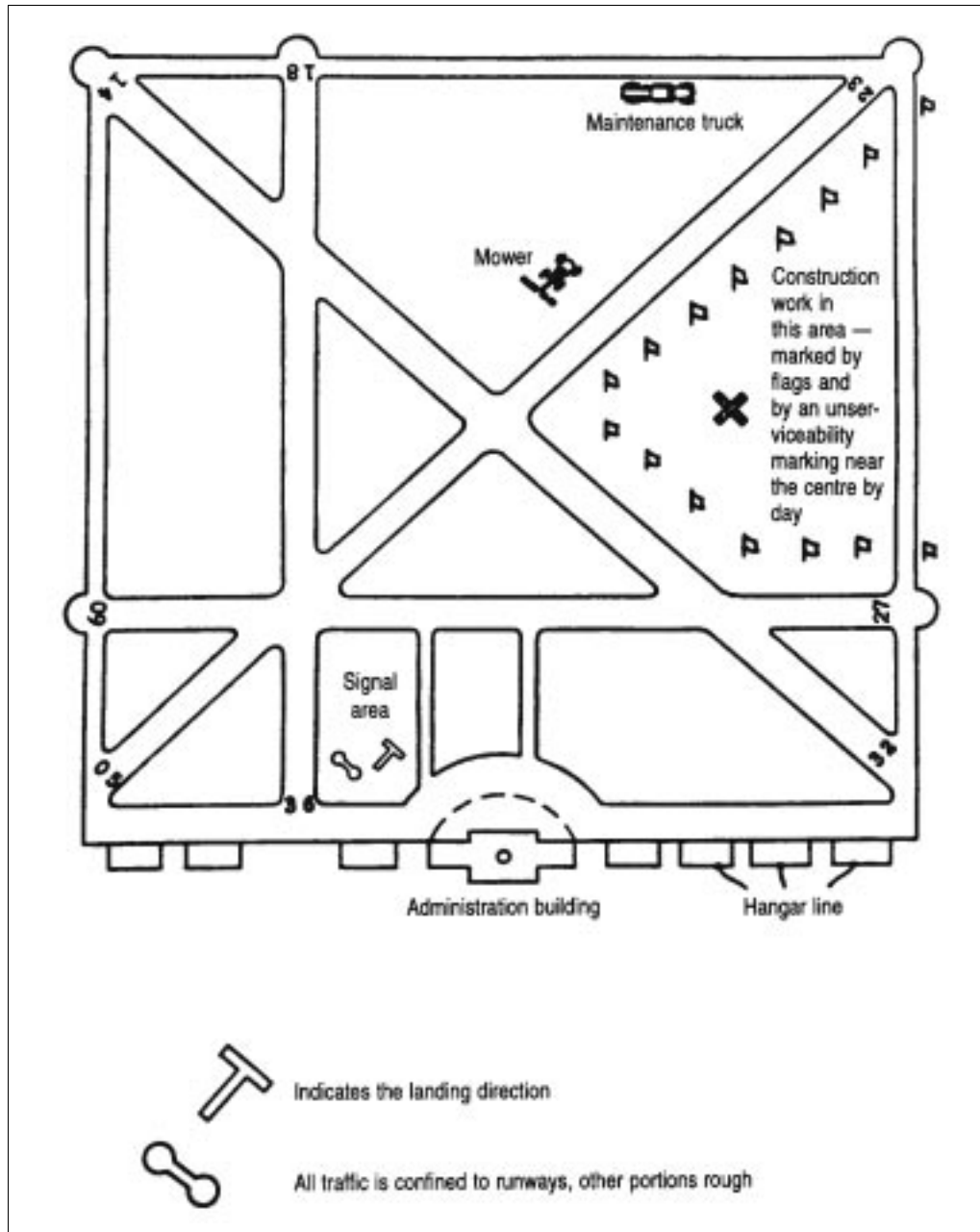

Figure V-3. Typical aerodrome showing various aerodrome conditions (see 8.2)

10. Control of taxiing aircraft

10.1 When taxiing, a pilot's vision is limited. It is important therefore for aerodrome control units to issue concise instructions and adequate information to the pilot to assist him to determine the correct taxi routes and to avoid collision with other aircraft or objects.

10.2 For the purpose of expediting air traffic, aircraft may be permitted to taxi on the runway-in-use, provided no delay or risk to other aircraft will result.

10.3 Except as provided in 10.3.1 or as prescribed by the appropriate ATS authority, aircraft shall not be held closer to the runway-in-use than at a runway-holding position.

Note.— Runway-holding position locations in relation to runways are specified in Annex 14, Volume I, Chapter 5.

10.3.1 Aircraft shall not be permitted to hold on the approach end of the runway-in-use whenever another aircraft is effecting a landing, until the landing aircraft has passed the point of intended holding.

Note.— See Figure V-4.

10.4 An aircraft known or believed to be the subject of unlawful interference or which for other reasons needs isolation from normal aerodrome activities shall be cleared to the designated isolated parking position. Where such an isolated parking position has not been designated, or if the designated position is not available, the aircraft shall be cleared to a position within the area or areas selected by prior agreement with the aerodrome authority. The taxi clearance shall specify the taxi route to be followed to the parking

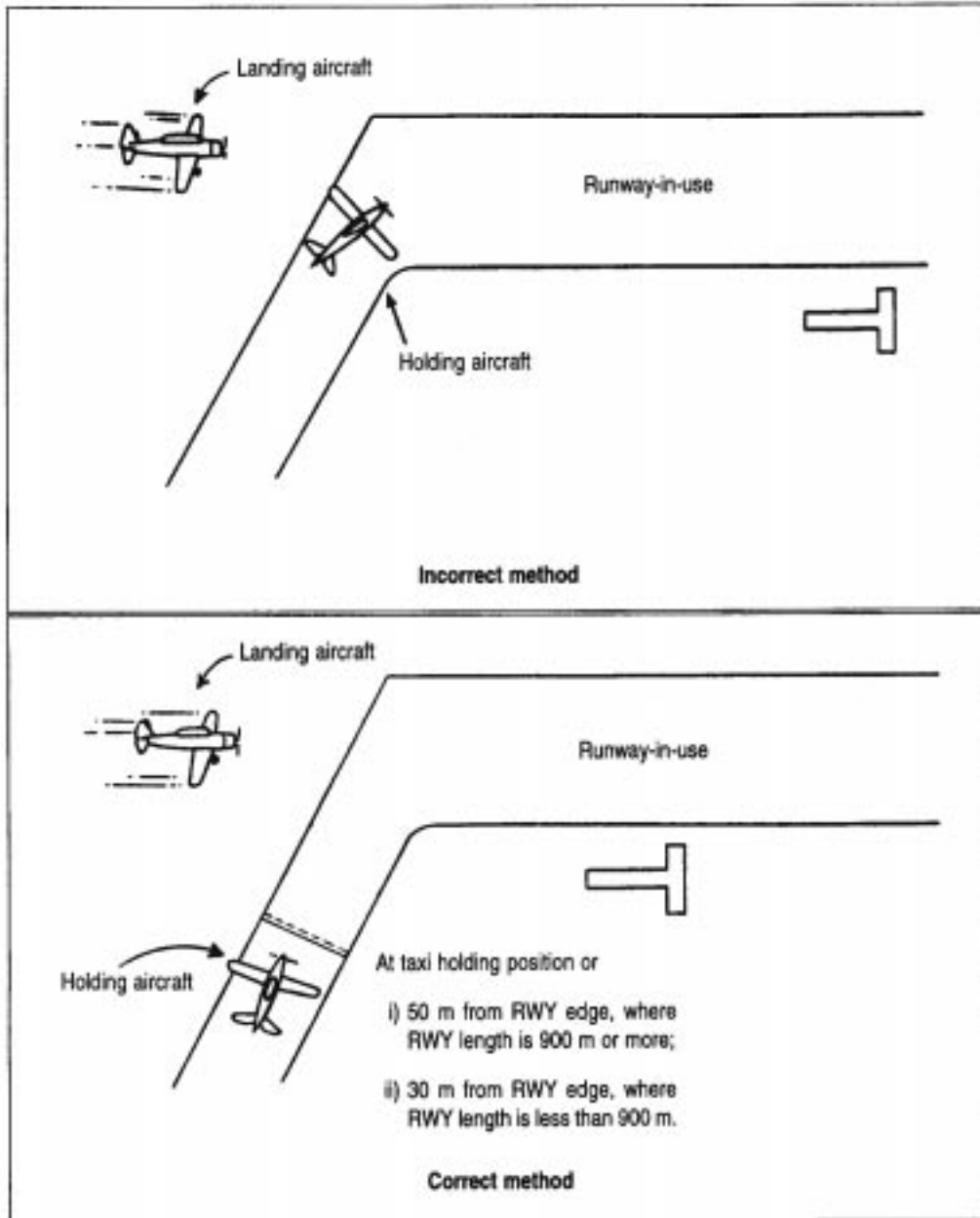

Figure V-4. Method of holding aircraft (see Section 10)

position. This route shall be selected with a view to minimizing any security risks to the public, other aircraft and installations at the aerodrome.

Note.— See Annex 14, Volume I, Chapter 3.

10.5 When necessary for a wheeled helicopter or VTOL to taxi on the surface, the following provisions are applicable.

Note.— Ground taxiing uses less fuel than air-taxiing and minimizes air turbulence. However, under certain conditions, such as rough, soft, or uneven terrain, it may become necessary to air-taxi for safety considerations. Helicopters with articulating rotors (usually designs with three or more main rotor blades) are subject to “ground resonance” and may, on rare occasions, suddenly lift off the ground to avoid severe damage or destruction.

10.5.1 When requested or necessary for a helicopter to proceed at a slow speed above the surface, normally below 37 km/h (20 kt) and in ground effect, air-taxiing may be authorized.

Note.— Air-taxiing consumes fuel at a high burn rate, and helicopter downwash turbulence (produced in ground effect) increases significantly with larger and heavier helicopters.

10.5.2 Instructions which require small aircraft or helicopters to taxi in close proximity to taxiing helicopters should be avoided and consideration should be given to the effect of turbulence from taxiing helicopters on arriving and departing light aircraft.

11. Control of other than aircraft traffic on the manoeuvring area

11.1 The movement of pedestrians or vehicles on the manoeuvring area shall be subject to authorization by the aerodrome control tower. Persons, including drivers of all vehicles, shall be required to obtain authorization from the aerodrome control tower before entry to the manoeuvring area. Notwithstanding such an authorization, entry to a runway or runway strip or change in the operation authorized shall be subject to a further specific authorization by the aerodrome control tower.

11.2 At controlled aerodromes all vehicles employed on the manoeuvring area shall be capable of maintaining two-way radiocommunication with the aerodrome control tower, except when the vehicle is only occasionally used on the manoeuvring area and is:

- a) accompanied by a vehicle with the required communications capability, or
- b) employed in accordance with a pre-arranged plan established with the aerodrome control tower.

11.2.1 When communications by a system of visual signals is deemed to be adequate, or in the case of radiocommunication failure, the signals given hereunder shall have the meaning indicated therein.

| <i>Light signal from aerodrome control</i> | <i>Meaning</i> |
|--|---|
| Green flashes | Permission to cross landing area or to move onto taxiway |
| Steady red | Stop |
| Red flashes | Move off the landing area or taxiway and watch out for aircraft |
| White flashes | Vacate manoeuvring area in accordance with local instructions |

11.2.2 In emergency conditions or if the signals in 11.2.1 are not observed the signal given hereunder shall be used for runways or taxiways equipped with a lighting system and shall have the meaning indicated therein.

| <i>Light signal</i> | <i>Meaning</i> |
|-----------------------------------|--|
| Flashing runway or taxiway lights | Vacate the runway and observe the tower for light signal |

11.2.3 When employed in accordance with a plan pre-arranged with the aerodrome control tower, constructional and maintenance personnel should not normally be required to be capable of maintaining two-way radiocommunication with the aerodrome control tower.

11.3 When an aircraft is landing or taking off, vehicles shall not be permitted to hold closer to the runway-in-use than:

- a) at a taxiway/runway intersection — at a runway-holding position; and
- b) at a location other than a taxiway/runway intersection — at a distance equal to the separation distance of the runway-holding position.

11.4 The aerodrome control tower shall, prior to a period of application of low visibility procedures, establish a record of vehicles and persons currently on the manoeuvring area and maintain this record during the period of application of these procedures to assist in assuring the safety of operations on that area.

12. Separation of aircraft and of aircraft and vehicles on the manoeuvring area

12.1 When there is a requirement for traffic to operate on the manoeuvring area in visibilities which require the aerodrome control to apply separation between aircraft, and between aircraft and vehicles, other than those specified in 10.3 and 11.3, the following shall apply:

12.1.1 At the intersection of taxiways, an aircraft or vehicle on a taxiway shall not be permitted to hold closer to the other taxiway than the holding position limit defined by a clearance bar, stop bar or taxiway intersection marking according to the specifications in Annex 14, Volume I, Chapter 5.

12.1.2 The longitudinal separation on taxiways shall be as specified for each particular aerodrome by the appropriate ATS authority. This separation shall take into account the characteristics of the aids available for surveillance and control of ground traffic, the complexity of the aerodrome layout and the characteristics of the aircraft using the aerodrome.

Note.— Movement of aircraft in these low visibility conditions postulates facility provision appropriate to the operation. The Manual of Surface Movement Guidance and Control Systems (SMGCS) (Doc 9476) provides guidance on surface movement guidance and control components and procedures.

13. Control of traffic in the traffic circuit

13.1 Aircraft in the traffic circuit shall be controlled to provide the separation minima outlined in 14.1, 15.1 and 16 except that:

- a) aircraft in formation are exempted from the separation minima with respect to separation from other aircraft of the same flight;

Rules of the Air and Air Traffic Services (PANS-RAC)

- b) aircraft operating in different areas or lanes on aerodromes equipped with runways or mat facilities suitable for simultaneous landings or take-offs are exempted from the separation minima;
- c) separation minima shall not apply to aircraft operating under military necessity in accordance with Part II, Section 6.

13.2 Sufficient separation shall be effected between aircraft in flight in the traffic circuit to allow the spacing of arriving and departing aircraft as outlined in 14.1, 15.1 and 16.

13.3 The clearance to enter the traffic circuit is issued to an aircraft whenever it is desired that the aircraft approach the landing area in accordance with current traffic circuits and traffic conditions are such that a clearance authorizing the actual landing is not feasible. In connexion with the clearance to enter the traffic circuit, information is given concerning the landing direction or runway-in-use so that the pilot-in-command of an aircraft may intelligently plan his entry into the traffic circuit.

13.4 If an aircraft enters an aerodrome traffic circuit without proper authorization, it shall be permitted to land if its actions indicate that it so desires. If circumstances warrant, a controller may ask aircraft with which he is in contact to give way so as to remove as soon as possible the hazard introduced by such unauthorized operation. In no case shall permission to land be withheld indefinitely.

13.5 In cases of emergency it may be necessary, in the interests of safety, for an aircraft to enter a traffic circuit and effect a landing without proper authorization. Controllers should recognize the possibilities of emergency action and render all assistance possible.

13.6 Special authorization for use of the manoeuvring area may be given to:

- a) an aircraft which anticipates being compelled to land because of factors affecting the safe operation of the aircraft (engine failure, shortage of fuel, etc.);
- b) hospital aircraft or aircraft carrying any sick or seriously injured persons requiring urgent medical attention.

14. Control of departing aircraft

14.1 Except as provided in 14.1.1 and 16, a departing aircraft will not normally be permitted to commence take-off

until the preceding departing aircraft has crossed the end of the runway-in-use or has started a turn or until all preceding landing aircraft are clear of the runway-in-use.

Note 1.— See Figure V-5.

Note 2.— Wake turbulence categorization of aircraft and longitudinal separation minima are contained in Section 16 and in Part VI, Section 7.

14.1.1 Lower minima than those in 14.1 may be prescribed by the appropriate ATS authority, after consultation with the operators, and taking into account such factors as:

- a) runway length;
- b) aerodrome layout; and
- c) types of aircraft involved.

Such lower minima shall not apply:

- i) between a departing aircraft and a preceding landing aircraft;

- ii) between sunset and sunrise, or such other period between sunset and sunrise as may be prescribed;
- iii) when braking action may be adversely affected by runway contaminants (e.g. slush, water, etc.);
- iv) in weather conditions preventing the pilot from making an early assessment of traffic conditions on the runway.

Note.— See the Air Traffic Services Planning Manual (Doc 9426) for details of such lower minima developed by one State.

14.2 Take-off clearance may be issued to an aircraft when there is reasonable assurance that the separation in 14.1, or prescribed in accordance with 14.1.1, will exist when the aircraft commences take-off.

14.3 When an air traffic control clearance from an area control centre is required prior to take-off, the take-off clearance shall not be issued until the area control centre clearance has been transmitted to and acknowledged by the aircraft concerned. The area control centre shall forward a

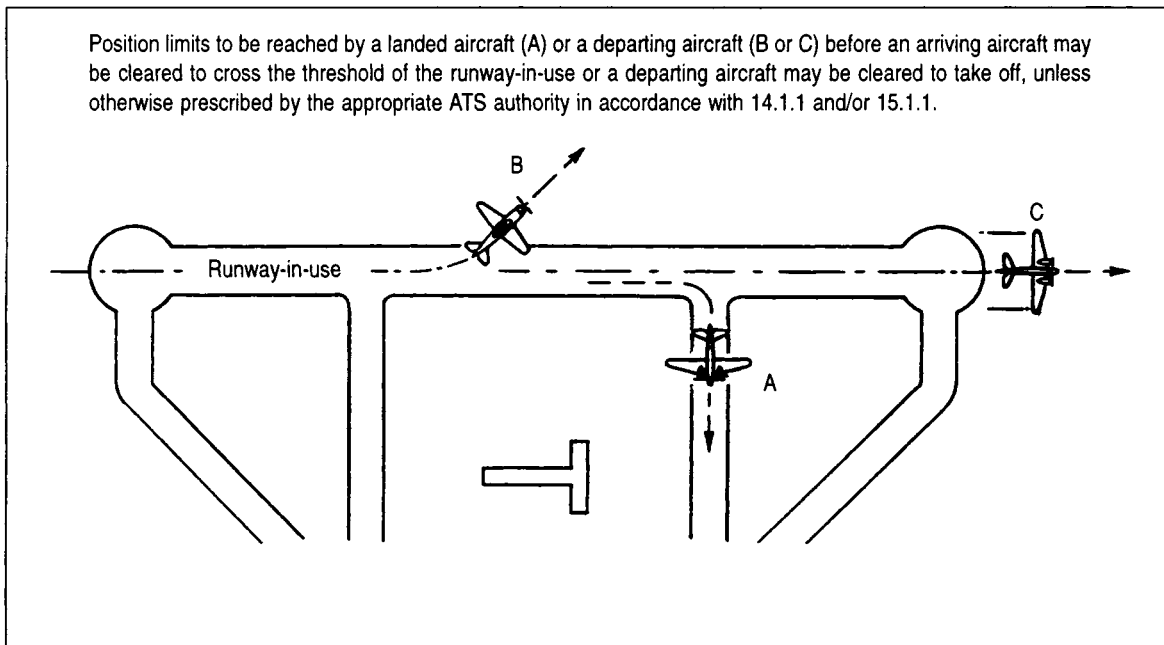

Figure V-5. Separation between landings and take-offs (see 14.1 and 15.1)

clearance to the aerodrome control tower with the least possible delay after receipt of a request made by the tower, or prior to such request if practicable.

14.4 Subject to 14.3, the take-off clearance shall be issued when the aircraft is ready for take-off and at or approaching the runway-in-use, and the traffic situation permits.

14.5 In the interest of expediting traffic a clearance for immediate take-off may be issued to an aircraft before it enters the runway. On acceptance of such clearance the aircraft shall taxi out to the runway and take off in one continuous movement.

15. Control of arriving aircraft

15.1 Except as provided in 15.1.1 and 16, a landing aircraft will not normally be permitted to cross the beginning of the runway on its final approach until the preceding departing aircraft has crossed the end of the runway-in-use, or has started a turn, or until all preceding landing aircraft are clear of the runway-in-use.

Note 1.— See Figure V-5.

Note 2.— Wake turbulence categorization of aircraft and longitudinal separation minima are contained in Section 16 and in Part VI, Section 7.

15.1.1 Lower minima than those in 15.1 may be prescribed by the appropriate ATS authority, after consultation with operators, and taking into consideration such factors as:

- a) runway length;
- b) aerodrome lay-out; and
- c) types of aircraft involved.

Such lower minima shall not apply:

- i) between sunset and sunrise, or such other period between sunset and sunrise as may be prescribed;
- ii) when braking action may be adversely affected by runway contaminants (e.g. slush, water, etc.);
- iii) in weather conditions preventing the pilot from making an early assessment of traffic conditions on the runway.

Rules of the Air and Air Traffic Services (PANS-RAC)

Note.— See the Air Traffic Services Planning Manual (Doc 9426) for details of such lower minima developed by one State.

15.2 An aircraft may be cleared to land when there is reasonable assurance that the separation in 15.1, or prescribed in accordance with 15.1.1, will exist when the aircraft crosses the runway threshold, provided that a clearance to land shall not be issued until a preceding landing aircraft has crossed the runway threshold.

16. Wake turbulence categorization of aircraft and increased longitudinal separation minima

Note.— The term “wake turbulence” is used in this context to describe the effect of the rotating air masses generated behind the wing tips of large jet aircraft, in preference to the term “wake vortex” which describes the nature of the air masses. Detailed characteristics of wake vortices and their effect on aircraft are contained in the Air Traffic Services Planning Manual (Doc 9426), Part II, Section 5.

16.1 Wake turbulence categorization of aircraft

16.1.1 Wake turbulence separation minima shall be based on a grouping of aircraft types into three categories according to the maximum certificated take-off mass as follows:

- a) HEAVY (H) — all aircraft types of 136 000 kg or more;
- b) MEDIUM (M) — aircraft types less than 136 000 kg but more than 7 000 kg; and
- c) LIGHT (L) — aircraft types of 7 000 kg or less.

16.1.2 Helicopters should be kept well clear of light aircraft when hovering or while air taxiing.

Note.— Helicopters produce vortices when in flight and there is some evidence that, per kilogramme of gross mass, their vortices are more intense than those of fixed-wing aircraft.

16.2 Wake turbulence
separation minima

Note.— The provisions governing wake turbulence radar separation minima are set forth in Part VI, Section 7.

16.2.1 The following non-radar separation minima shall be applied:

16.2.2 *Arriving aircraft*

16.2.2.1 For timed approaches, the following minima shall be applied to aircraft landing behind a HEAVY or a MEDIUM aircraft:

- a) MEDIUM aircraft behind HEAVY aircraft — 2 minutes;
- b) LIGHT aircraft behind a HEAVY or MEDIUM aircraft — 3 minutes.

16.2.3 *Departing aircraft*

16.2.3.1 Except as set forth in 16.2.3.2 a minimum of 2 minutes shall be applied between a LIGHT or MEDIUM aircraft taking off behind a HEAVY aircraft or a LIGHT aircraft taking off behind a MEDIUM aircraft when the aircraft are using:

- a) the same runway;
- b) parallel runways separated by less than 760 m;
- c) crossing runways if the projected flight path of the second aircraft will cross the projected flight path of the first aircraft at the same altitude or less than 300 m (1 000 ft) below;
- d) parallel runways separated by 760 m or more, if the projected flight path of the second aircraft will cross the projected flight path of the first aircraft at the same altitude or less than 300 m (1 000 ft) below.

Note.— See Figure V-6 and Figure V-7.

16.2.3.2 A separation minimum of 3 minutes shall be applied between a LIGHT or MEDIUM aircraft when taking off behind a HEAVY aircraft or a LIGHT aircraft when taking off behind a MEDIUM aircraft from:

- a) an intermediate part of the same runway; or
- b) an intermediate part of a parallel runway separated by less than 760 m.

Note.— See Figure V-8.

16.2.4 *Displaced landing threshold*

16.2.4.1 A separation minimum of 2 minutes shall be applied between a LIGHT or MEDIUM aircraft and a HEAVY aircraft and between a LIGHT aircraft and a MEDIUM aircraft when operating on a runway with a displaced landing threshold when:

- a) a departing LIGHT or MEDIUM aircraft follows a HEAVY aircraft arrival and a departing LIGHT aircraft follows a MEDIUM aircraft arrival; or
- b) an arriving LIGHT or MEDIUM aircraft follows a HEAVY aircraft departure and an arriving LIGHT aircraft follows a MEDIUM aircraft departure if the projected flight paths are expected to cross.

16.2.5 *Opposite direction*

16.2.5.1 A separation minimum of 2 minutes shall be applied between a LIGHT or MEDIUM aircraft and a HEAVY aircraft and between a LIGHT aircraft and a MEDIUM aircraft when the heavier aircraft is making a low or missed approach and the lighter aircraft is:

- a) utilizing an opposite-direction runway for take-off; or

Note.— See Figure V-9.

- b) landing on the same runway in the opposite direction, or on a parallel opposite-direction runway separated by less than 760 m.

Note.— See Figure V-10.

17. Authorization of special VFR flights

17.1 When traffic conditions permit, special VFR flights may be authorized subject to the approval of the unit providing approach control service and the provisions of 17.2 hereafter.

**WAKE TURBULENCE SEPARATION MINIMA FOR
CROSSING AND FOLLOWING AIRCRAFT**

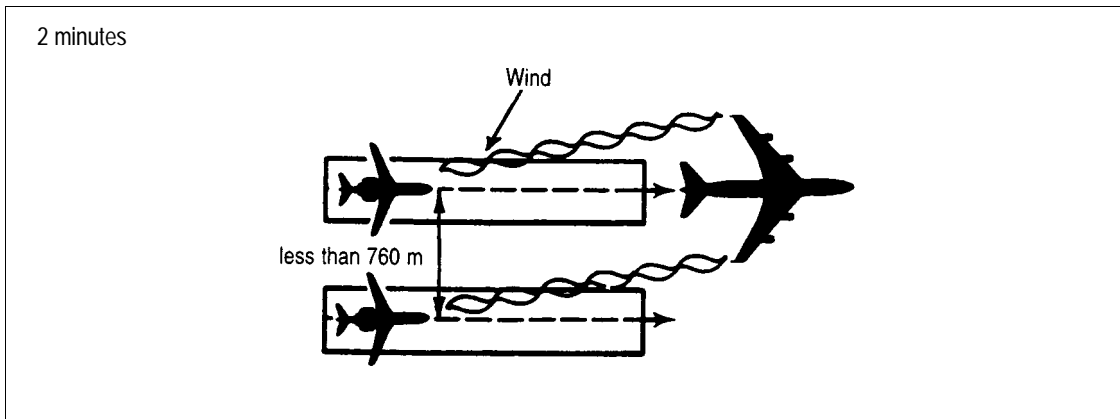

Figure V-6 (see 16.2.3.1 b))

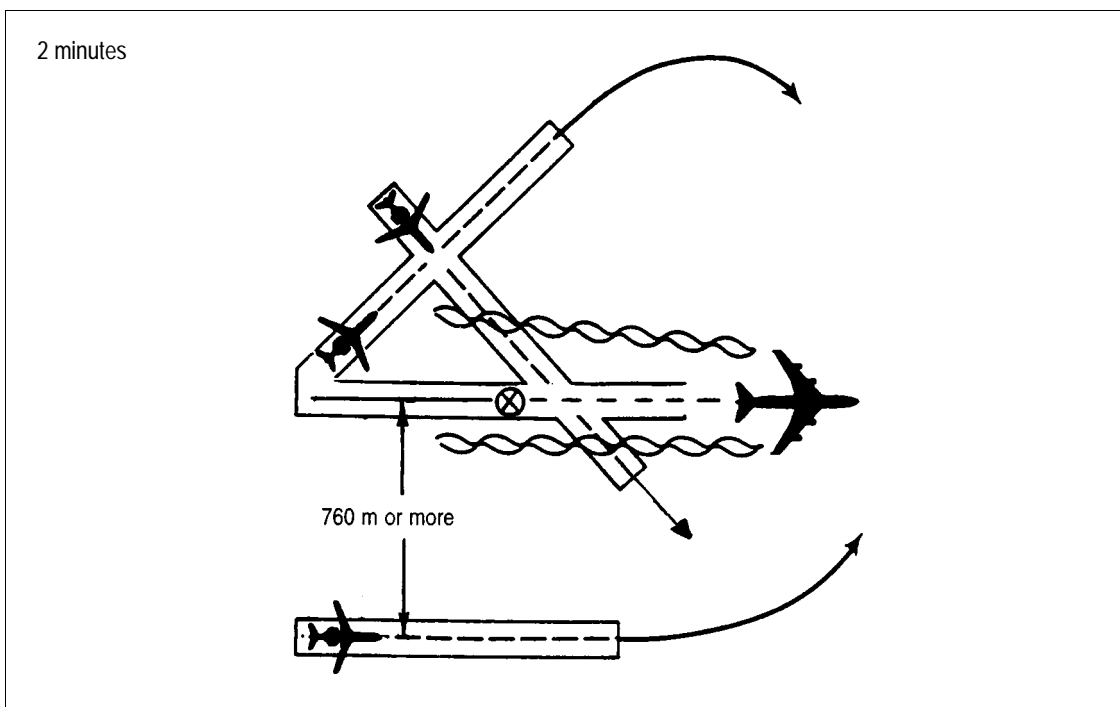

Figure V-7 (see 16.2.3.1 c) and d))

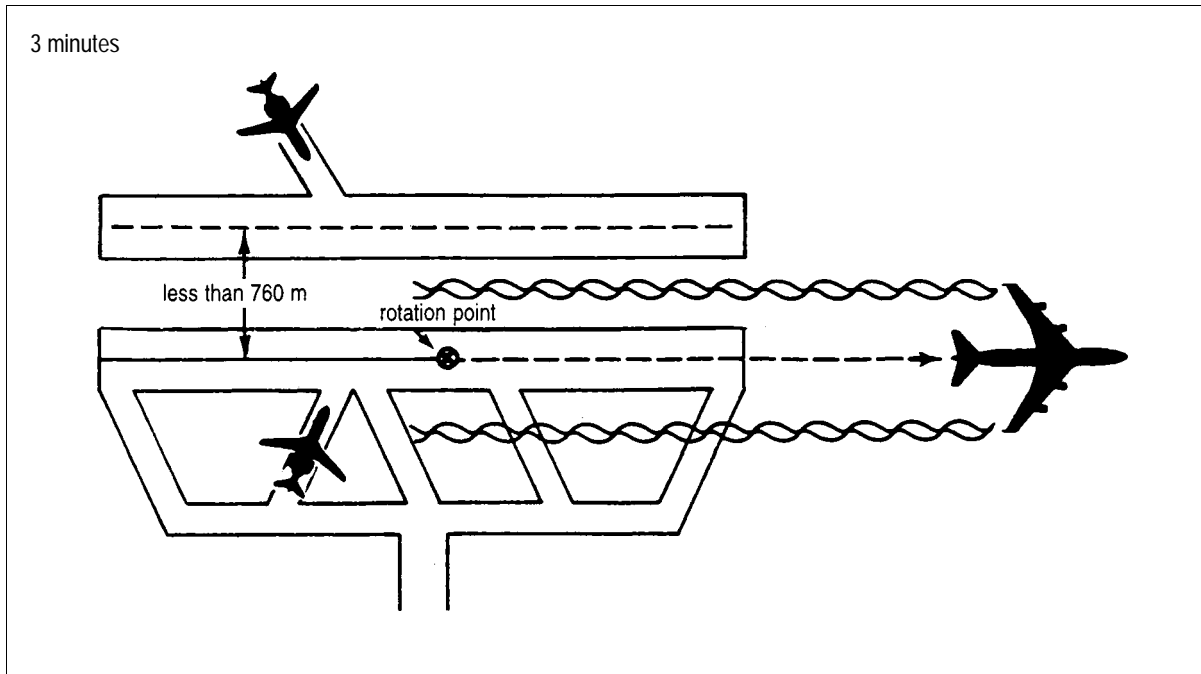

Figure V-8 (see 16.2.3.2 a) and b))

FOR OPPOSITE-DIRECTION AIRCRAFT

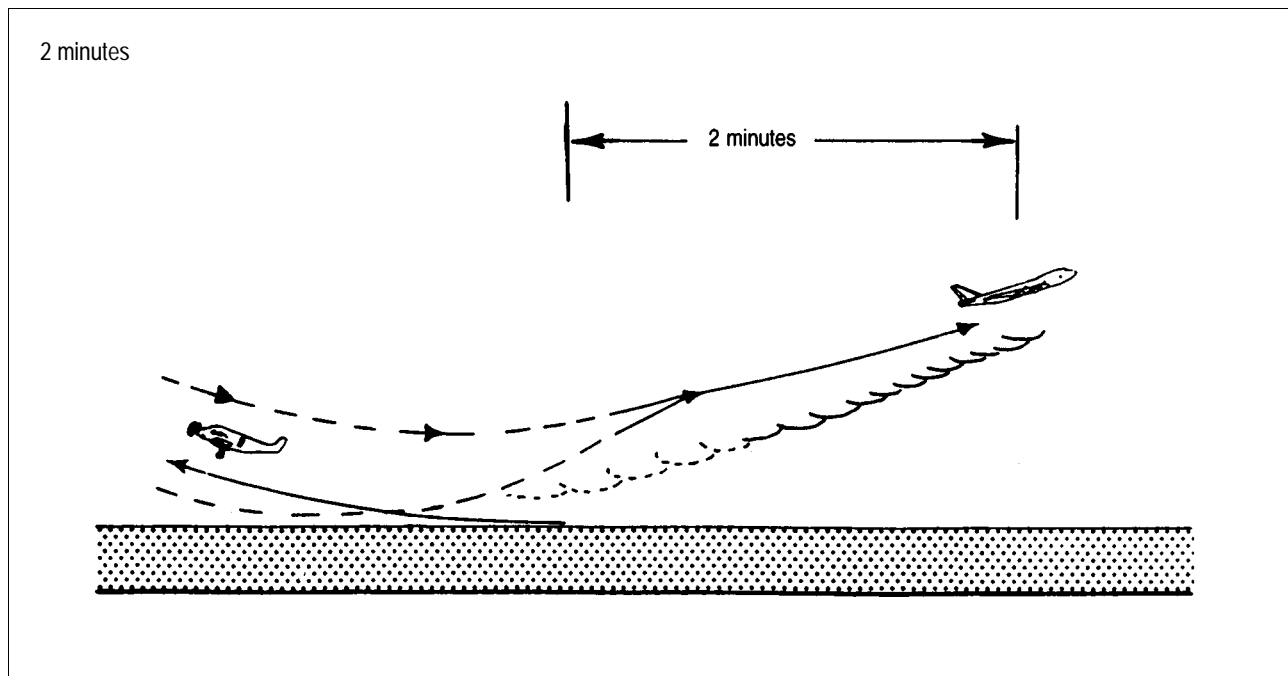

Figure V-9 (see 16.2.5.1 a))

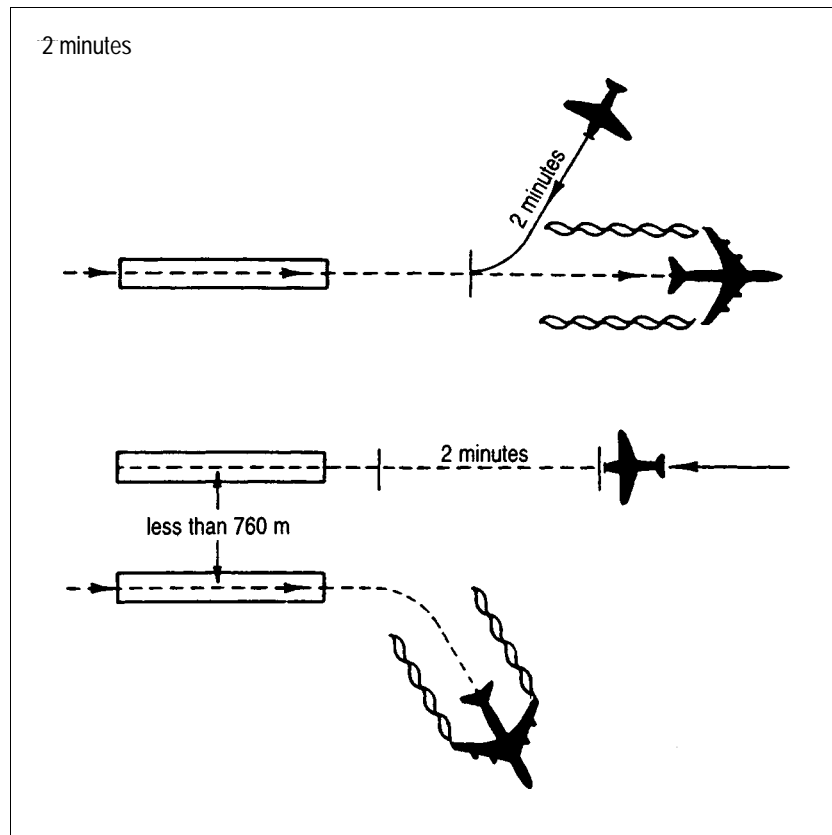

Figure V-10 (see 16.2.5.1 b))

17.1.1 Requests for such authorization shall be handled individually.

17.1.2 Separation shall be effected between all IFR flights and special VFR flights in accordance with separation minima in Parts III and IV and, when so prescribed by the appropriate ATS authority, between all special VFR flights in accordance with separation minima prescribed by that authority.

17.2 When the ground visibility is not less than 1 500 m, special VFR flights may be authorized to enter a control zone for the purpose of landing, to take off and depart from a control zone, to cross a control zone, or to operate locally within a control zone.

Note.— Requirements for two-way communications between controlled flights and the appropriate air traffic control unit are contained in Annex 2, 3.6.5.

PART VI. RADAR SERVICES

1. Radar systems capabilities

1.1 Radar systems used in the provision of air traffic services shall have a very high level of reliability, availability and integrity. The possibility of system failures or significant system degradations which may cause complete or partial interruptions of service shall be very remote. Back-up facilities shall be provided.

Note 1.— A radar system will normally consist of a number of integrated elements, including radar sensor(s), radar data transmission lines, radar data processing system, radar displays.

Note 2.— Guidance material and information pertaining to use of radar and to system reliability and availability is contained in Annex 10, Volume I and the Air Traffic Services Planning Manual (Doc 9426).

1.2 Multi-radar systems, i.e. systems utilizing more than one radar sensor, should have the capability to receive, process and display, in an integrated manner, data from all the connected sensors.

1.3 Radar systems should be capable of integration with other automated systems used in the provision of ATS, and should provide for an appropriate level of automation with the objectives of improving the accuracy and timeliness of data displayed to the controller and reducing controller workload and the need for verbal co-ordination between adjacent control positions and ATC units.

1.4 Radar systems should provide for the display of safety-related alerts and warnings, including conflict alert, minimum safe altitude warning, conflict prediction and unintentionally duplicated SSR codes.

1.5 States should, to the extent possible, facilitate the sharing of radar information in order to extend and improve radar coverage in adjacent control areas.

1.6 States should, on the basis of regional air navigation agreements, provide for the automated exchange of co-ordination data relevant to aircraft being provided with radar services, and establish automated co-ordination procedures.

1.7 Primary surveillance radar (PSR) and secondary surveillance radar (SSR) may be used either alone or in combination in the provision of air traffic services, including in the provision of separation between aircraft, provided:

- a) reliable coverage exists in the area; and
- b) the probability of detection, the accuracy and the integrity of the radar system(s) are satisfactory.

1.8 PSR systems should be used in circumstances where SSR alone would not meet the air traffic services requirements.

1.9 SSR systems, especially those with monopulse technique or Mode S capability, may be used alone, including in the provision of separation between aircraft, provided:

- a) the carriage of SSR transponders is mandatory within the area; and
- b) aircraft identification is established and maintained by use of assigned discrete SSR codes.

Note.— Monopulse technique is a radar technique in which azimuth information of an SSR transponder aircraft is derivable from each pulse detection by comparison of signals received simultaneously in two or more antenna beams. Monopulse SSR sensors provide for an improved azimuth resolution and less fruit and garbling compared to conventional SSR sensors.

1.10 The use of radar in air traffic services shall be limited to specified areas of radar coverage and shall be subject to such other limitations as have been specified by the appropriate ATS authority. Adequate information on the operating methods used shall be published in aeronautical information publications, as well as operating practices and/or equipment limitations having direct effects on the operation of the air traffic services.

Note.— States will provide information on the area or areas where PSR and SSR are in use as well as radar services and procedures in accordance with Annex 15, 4.1.1 and Appendix 1.

1.11 Where PSR and SSR are required to be used in combination, SSR alone may be used in the event of PSR failure to provide separation between identified transponder-equipped aircraft, provided the accuracy of the SSR position indications has been verified by monitor equipment or other means.

2. Presentation of radar information

2.1 Radar-derived information available for display to the controller shall, as a minimum, include radar position indications, radar map information and, when available, information from SSR Mode A, Mode C and Mode S.

2.2 The radar system shall provide for a continuously updated presentation of radar-derived information, including radar position indications.

2.3 Radar position indications may be displayed as:

- a) radar position symbols (RPS), including:
 - i) PSR symbols;
 - ii) SSR symbols; and
 - iii) combined PSR/SSR symbols;

b) PSR blips;

c) SSR responses.

2.4 When applicable, distinct symbols should be used for presentation of:

- a) unintentionally duplicated SSR codes;
- b) predicted positions for a non-updated track; and
- c) plot and track data.

2.5 Reserved SSR codes, including 7500, 7600 and 7700, operation of IDENT, safety-related alerts and warnings as well as information related to automated co-ordination shall be presented in a clear and distinct manner, providing for ease of recognition.

2.6 Radar labels should be used to provide, in alphanumeric form, SSR-derived as well as other information which may be available.

Rules of the Air and Air Traffic Services (PANS-RAC)

2.7 Radar label information shall as a minimum include the SSR code transmitted by an aircraft or, when code/call sign conversion is effected, aircraft identification, and SSR Mode C-derived level information. All label information shall be presented in a clear and concise manner.

2.8 Radar labels shall be associated with their radar position indications in a manner precluding erroneous identification by or confusion on the part of the controller.

3. Communications

3.1 The level of reliability and availability of communications systems shall be such that the possibility of system failures or significant degradations is very remote. Adequate backup facilities shall be provided.

Note.— Guidance material and information pertaining to system reliability and availability are contained in Annex 10, Volume I and the Air Traffic Services Planning Manual (Doc 9426).

3.2 Direct pilot-controller communications shall be established prior to the provision of radar services, unless special circumstances such as emergencies dictate otherwise.

4. Provision of radar services

4.1 Where suitable radar systems and communication systems are available, radar-derived information, including safety-related alerts and warnings such as conflict alert and minimum safe altitude warning, should be used to the extent possible in the provision of air traffic control service in order to improve capacity and efficiency as well as to enhance safety.

4.2 The number of aircraft simultaneously provided with radar services shall not exceed that which can safely be handled under the prevailing circumstances, taking into account:

- a) the structural complexity of the control area or sector concerned;
- b) the radar functions to be performed within the control area or sector concerned;
- c) assessments of controller workloads and sector capacity;

- d) the degree of technical reliability and availability of the main radar and communication systems;
- e) the possibility of a radar equipment failure or other emergency that would eventually require reverting to back-up facilities and/or non-radar separation; and
- f) the degree of technical reliability and availability of the back-up radar and communication systems.

4.3 Where traffic density varies significantly on a daily or periodic basis, facilities and procedures should be implemented to vary the number of operational radar positions and/or sectors in order to meet the prevailing and anticipated traffic demand.

5. Use of SSR transponders

5.1 To ensure the safe and efficient use of SSR, pilots and controllers shall strictly adhere to published operating procedures. Standard radiotelephony phraseology shall be used and the correct setting of transponder codes shall be ensured at all times.

5.2 SSR Code management

5.2.1 Codes 7700, 7600 and 7500 shall be reserved internationally for use by pilots encountering a state of emergency, radiocommunication failure or unlawful interference respectively.

5.2.2 SSR Codes are to be allocated and assigned in accordance with the following principles.

5.2.2.1 Codes should be allocated to States or areas in accordance with regional air navigation agreements, taking into account overlapping radar coverage over adjacent airspaces.

5.2.2.2 The appropriate ATS authority shall establish a plan and procedures for the allocation of codes to ATS units.

5.2.2.3 The plan and procedures should be compatible with those practised in adjacent States.

5.2.2.4 The allocation of a code should preclude the use of this code for any other function within the area of coverage of the same SSR for a prescribed time period.

5.2.2.5 To reduce pilot and controller workload and the need for controller/pilot communications, the number of code changes required of the pilot should be kept to the minimum.

5.2.2.6 Codes shall be assigned to aircraft in accordance with the plan and procedures laid down by the appropriate ATS authority.

5.2.2.7 Where there is a need for individual aircraft identification, each aircraft shall be assigned a discrete code which should, whenever possible, be retained throughout the flight.

5.2.3 SSR Codes shall be reserved, as necessary, for exclusive use by medical aircraft operating in areas of international armed conflict. SSR Codes shall be allocated by ICAO through its Regional Offices in co-ordination with States concerned, and should be assigned to aircraft for use within the area of conflict.

Note.— The term “medical aircraft” refers to aircraft protected under the Geneva Conventions of 1949 and under the Protocol Additional to the Geneva Conventions of 12 August 1949, and relating to the protection of victims of international armed conflicts (Protocol I).

5.3 Operation of SSR transponders

Note.— SSR transponder operating procedures are contained in Procedures for Air Navigation Services — Aircraft Operations (PANS-OPS, Doc 8168), Volume I, Part VIII.

5.3.1 When, after a pilot has been directed to operate the aircraft's transponder on an assigned code, or to effect a code change, it is observed that the code shown on the radar display is different from that assigned to the aircraft, the pilot shall be requested to reselect the assigned code.

5.3.2 Whenever it is observed that the code of an aircraft as shown on the radar display, or aircraft identification where code/call sign conversion is effected, is different from that assigned to the aircraft and the application of the procedure described in 5.3.1 above has not resolved this discrepancy or is not warranted by circumstances (e.g. unlawful interference), the pilot shall be requested to confirm the correct code has been selected.

5.3.3 If the discrepancy still persists, the pilot may be requested to stop the operation of the aircraft's transponder.

The next control position and any other affected unit using SSR in the provision of ATS shall be informed accordingly.

5.3.4 Aircraft equipped with Mode S having an aircraft identification feature shall transmit the aircraft identification as specified in Item 7 of the ICAO flight plan or, when no flight plan has been filed, the aircraft registration.

Note.— All Mode S-equipped aircraft engaged in international civil aviation are required to have an aircraft identification feature (Annex 10, Volume IV, Chapter 2, 2.1.5.2 refers).

5.3.5 Whenever it is observed on the radar display that the aircraft identification transmitted by a Mode S-equipped aircraft is different from that expected from the aircraft, the pilot shall be requested to reselect aircraft identification.

5.3.6 If, following confirmation by the pilot that the correct aircraft identification has been set on the Mode S identification feature, the discrepancy continues to exist, the following actions shall be taken by the controller:

- a) inform the pilot of the persistent discrepancy;
- b) where possible, rectify the radar label showing the aircraft identification on the radar display; and
- c) notify the erroneous identification transmitted by the aircraft to the next control position and any other interested unit using Mode S for identification purposes.

5.4 Level information based on the use of Mode C

5.4.1 Verification of accuracy of Mode C-derived level information

5.4.1.1 The tolerance value used to determine that Mode C-derived level information displayed to the controller is accurate shall be ± 90 m (± 300 ft).

5.4.1.2 Verification of the accuracy of Mode C-derived level information displayed to the controller shall be effected at least once by each suitably equipped ATC unit on initial contact with the aircraft concerned or, if this is not feasible, as soon as possible thereafter. The verification shall be effected by simultaneous comparison with altimeter-derived level information received from the same aircraft by radio-telephony. The pilot of the aircraft whose Mode C-derived level information is within the approved tolerance value need not be advised of such verification.

Rules of the Air and Air Traffic Services (PANS-RAC)

5.4.1.3 If the displayed level information is not within the approved tolerance value or when a discrepancy in excess of the approved tolerance value is detected subsequent to verification, the pilot shall be advised accordingly and requested to check the pressure setting and confirm the aircraft's level.

5.4.1.4 If, following confirmation of the correct pressure setting the discrepancy continues to exist, the following action should be taken according to circumstances:

- a) request the pilot to stop Mode C transmission, provided this does not interrupt the operation of the transponder on Mode A and notify the next control positions or ATC unit concerned with the aircraft of the action taken; or
- b) inform the pilot of the discrepancy and request that Mode C operation continue in order to prevent loss of position and identity information on the aircraft and notify the next control position or ATC unit concerned with the aircraft of the action taken.

5.4.2 Determination of level occupancy

5.4.2.1 The criterion which shall be used to determine that a specific level is occupied by an aircraft shall be ± 90 m (± 300 ft), except that appropriate ATS authorities may specify a smaller criterion but not less than ± 60 m (± 200 ft) if this is found to be more practical.

Note.— For a brief explanation of the considerations underlying this value see the Air Traffic Services Planning Manual (Doc 9426).

5.4.2.2 *Aircraft maintaining a level.* An aircraft is considered to be maintaining its assigned level as long as the SSR Mode C-derived level information indicates that it is within ± 90 m (± 300 ft) of the assigned level.

5.4.2.3 *Aircraft vacating a level.* An aircraft cleared to leave a level is considered to have commenced its manoeuvre and vacated the previously occupied level when the SSR Mode C-derived level information indicates a change of more than 90 m (300 ft) in the anticipated direction from its previously assigned level.

5.4.2.4 *Aircraft passing a level in climb or descent.* An aircraft in climb or descent is considered to have crossed a level when the SSR Mode C-derived level information indicates that it has passed this level in the required direction by more than 90 m (300 ft).

5.4.2.5 *Aircraft reaching a level.* An aircraft is considered to have reached the level to which it has been cleared when three consecutive renewals of Mode C-derived level information have indicated that it is within 90 m (300 ft) of its assigned level.

Note.— In automated ATS systems, the cycles of renewals of Mode C data may not be evident to controllers. It may, therefore, be necessary to specify in instructions to controllers the number of display repetition cycles, or a time interval, corresponding to three consecutive renewals of Mode C data.

5.4.2.6 Intervention by a controller shall only be required if differences in level information between that displayed to the controller and that used for control purposes are in excess of the values stated above.

6. General radar procedures

6.1 Performance checks

6.1.1 The radar controller shall adjust the radar display(s) and carry out adequate checks on the accuracy thereof, in accordance with the technical instructions prescribed by the appropriate authority for the radar equipment concerned.

6.1.2 The radar controller shall be satisfied that the available functional capabilities of the radar system as well as the information presented on the radar display(s) is adequate for the functions to be performed.

6.1.3 The radar controller shall report, in accordance with local procedures, any fault in the equipment, or any incident requiring investigation, or any circumstances which make it difficult or impractical to provide radar services.

6.2 Identification of aircraft

6.2.1 Establishment of radar identification

6.2.1.1 Before providing radar service to an aircraft, radar identification shall be established and the pilot informed. Thereafter, radar identification shall be maintained until termination of the radar service.

6.2.1.2 If radar identification is subsequently lost, the pilot shall be informed accordingly and, when applicable, appropriate instructions issued.

6.2.1.3 Radar identification shall be established by at least one of the following methods.

6.2.2 SSR identification procedures

6.2.2.1 Where SSR is used, aircraft may be identified by one or more of the following procedures:

- a) recognition of the aircraft identification in a radar label;

Note.— The use of this procedure requires that the code/call sign correlation is achieved successfully, taking into account the Note following b) below.

- b) recognition of an assigned discrete code, the setting of which has been verified, in a radar label;

Note.— The use of this procedure requires a system of code assignment which ensures that each aircraft in a given portion of airspace is assigned a discrete code (see 5.2.2.7).

- c) direct recognition of the aircraft identification of a Mode S-equipped aircraft in a radar label;

Note.— Aircraft identification feature available in Mode S transponders provides the means to identify directly individual aircraft on radar displays and thus offers the potential to eliminate ultimately the recourse to Mode A discrete codes for individual identification. This elimination will only be achieved in a progressive manner depending on the state of deployment of suitable ground and airborne installations.

- d) by transfer of radar identification (see 6.3);
- e) observation of compliance with an instruction to set a specific code;
- f) observation of compliance with an instruction to squawk IDENT;

Note 1.— In automated radar systems, the “IDENT” feature may be presented in different ways, e.g. as a flashing of all or part of the radar position and associated data block.

Note 2.— Garbling of transponder replies may produce “IDENT”-type of indications. Nearly simultaneous “IDENT” transmissions within the same area may give rise to errors in identification.

6.2.2.2 When a discrete code has been assigned to an aircraft, a check shall be made at the earliest opportunity to ensure that the code set by the pilot is identical to that assigned for the flight. Only after this check has been made shall the discrete code be used as a basis for identification.

6.2.3 PSR identification procedures

6.2.3.1 Where SSR is not used or available, radar identification shall be established by at least one of the following methods:

- a) by correlating a particular radar position indication with an aircraft reporting its position over, or as bearing and distance from, a point displayed on the radar map, and by ascertaining that the track of the particular radar position is consistent with the aircraft path or reported heading;

Note 1.— Caution must be exercised when employing this method since a position reported in relation to a point may not coincide precisely with the radar position indication of the aircraft on the radar map. The appropriate ATS authority may, therefore, prescribe additional conditions for the application of this method, e.g.:

- i) a level or levels above which this method may not be applied in respect of specified navigation aids; or*
- ii) a distance from the radar site beyond which this method may not be applied.*

Note 2.— The term “a point” refers to a geographical point suitable for the purposes of radar identification. It is normally a reporting point defined by reference to a radio navigation aid or aids.

- b) by correlating an observed radar position indication with an aircraft which is known to have just departed, provided that the identification is established within 2 km (1 NM) from the end of the runway used. Particular care should be taken to avoid confusion with aircraft holding over or overflying the aerodrome, or with aircraft departing from or making a missed approach over adjacent runways;

Rules of the Air and Air Traffic Services (PANS-RAC)

- c) by transfer of radar identification (see 6.3);
- d) by ascertaining the aircraft heading, if circumstances require, and following a period of track observation:
 - instructing the pilot to execute one or more changes of heading of 30 degrees or more and correlating the movements of one particular radar position indication with the aircraft’s acknowledged execution of the instructions given; or
 - correlating the movements of a particular radar position indication with manoeuvres currently executed by an aircraft having so reported.

When using these methods, the radar controller shall:

- i) verify that the movements of not more than one radar position indication correspond with those of the aircraft; and
- ii) ensure that the manoeuvre(s) will not carry the aircraft outside the coverage of the radar display;

Note 1.— Caution must be exercised when employing these methods in areas where route changes normally take place.

Note 2.— With reference to ii) above, see also 6.5.1 regarding radar vectoring of controlled aircraft.

6.2.3.2 Use may be made of direction-finding bearings to assist in radar identification of an aircraft. This method, however, shall not be used as the sole means of establishing radar identification, unless so prescribed by the appropriate ATS authority for particular cases under specified conditions.

6.2.3.3 When two or more radar position indications are observed in close proximity, or are observed to be making similar movements at the same time, or when doubt exists as to the identity of a radar position indication for any other reason, changes of heading should be prescribed or repeated as many times as necessary, or additional methods of identification should be employed, until all risk of error in identification is eliminated.

6.3 Transfer of radar identification

6.3.1 Transfer of radar identification from one radar controller to another should only be attempted, when it is considered that the aircraft is within the accepting controller’s radar coverage.

6.3.2 Transfer of radar identification shall be effected by one of the following methods:

- a) designation of the radar position indication by automated means, provided that only one radar position indication is thereby indicated and there is no possible doubt of correct identification;
- b) notification of the discrete code of the aircraft;

Note.— The use of this procedure requires a system of code assignment which ensures that each aircraft in a given portion of airspace is assigned a discrete code (see 5.2.2.7).
- c) notification that the aircraft is Mode S-equipped with an aircraft identification feature when Mode S coverage is available;
- d) direct designation (pointing with the finger) of the radar position indication, if the two radar displays are adjacent, or if a common “conference” type of radar display is used;

Note.— Attention must be given to any errors which might occur due to parallax effects.

- e) designation of the radar position indication by reference to, or in terms of bearing and distance from, a geographical position or navigational facility accurately indicated on both radar displays, together with the track of the observed radar position indication if the route of the aircraft is not known to both controllers;

Note.— Caution must be exercised before establishing radar identification using this method, particularly if other radar position indications are observed on similar headings and in close proximity to the aircraft under radar control. Inherent radar deficiencies, such as inaccuracies in bearing and distance of the radar position indications displayed on individual radars and parallax errors, may cause the indicated position of an aircraft in relation to the known point to differ between the two radar displays. The appropriate ATS authority may, therefore, prescribe additional conditions for the application of this method, e.g.:

- i) a maximum distance from the common reference point used by the two controllers; and

ii) a maximum distance between the radar position indication as observed by the accepting controller and the one stated by the transferring controller.

- f) instruction to the aircraft by the transferring controller to change code and the observation of the change by the accepting controller; or
- g) instruction to the aircraft by the transferring controller to squawk IDENT and observation of this response by the accepting controller;

Note.— Use of procedures f) and g) requires prior co-ordination between the controllers, since the indications to be observed by the accepting controller are of short duration.

6.4 Position information

6.4.1 An aircraft provided with radar service should be informed of its position in the following circumstances:

- a) upon identification, except when the identification is established:
 - i) based on the pilot’s report of the aircraft position or within one nautical mile of the runway upon departure and the observation is consistent with the aircraft’s time of departure; or
 - ii) by use of assigned discrete SSR codes or Mode S and the location of the observed radar position indication is consistent with the current flight plan of the aircraft; or
 - iii) by transfer of radar identification;
- b) when the pilot requests this information;
- c) when a pilot’s estimate differs significantly from the radar controller’s estimate based on radar observation;
- d) when the pilot is instructed to resume own navigation after radar vectoring if the current instructions had diverted the aircraft from a previously assigned route, (see 6.5.5);
- e) immediately before termination of radar service, if the aircraft is observed to deviate from its intended route.

6.4.2 Position information shall be passed to aircraft in one of the following forms:

- a) as a well-known geographical position;
- b) magnetic track and distance to a significant point, an en-route navigation aid, or an approach aid;
- c) direction (using points of the compass) and distance from a known position;
- d) distance to touchdown, if the aircraft is on final approach; or
- e) distance and direction from the centre line of an ATS route.

6.4.3 Whenever practicable, position information shall relate to positions or routes pertinent to the navigation of the aircraft concerned and displayed on the radar map.

6.4.4 When so informed, the pilot may omit position reports at compulsory reporting points or report only over those reporting points specified by the air traffic services unit concerned, including points at which air-reports are required for meteorological purposes. Pilots shall resume position reporting when so instructed and when advised that radar service is terminated or that radar identification is lost.

6.5 Radar vectoring

6.5.1 Radar vectoring shall be achieved by issuing to the pilot specific headings which will enable the aircraft to maintain the desired track. When vectoring an aircraft, a radar controller should comply with the following:

- a) whenever practicable, the aircraft should be vectored along routes or tracks on which the pilot can monitor the aircraft position with reference to pilot-interpreted navigation aids (this will minimize the amount of radar navigational assistance required and alleviate the consequences resulting from a radar failure);
- b) when an aircraft is given a vector diverting it from a previously assigned route, the pilot should be informed, unless it is self-evident, what the vector is to accomplish and, when possible, the limit of the vector should be specified (e.g. to ... position, for ... approach);
- c) except when transfer of radar control is to be effected, aircraft shall not be vectored closer than 4.6 km (2.5 NM), or, where a radar separation minimum

Rules of the Air and Air Traffic Services (PANS-RAC)

greater than 9.3 km (5 NM) is prescribed, a distance equivalent to one half of the prescribed separation minimum, from the limit of the airspace for which the radar controller is responsible, unless local arrangements have been made to ensure that separation will exist with radar-controlled aircraft operating in adjoining areas;

- d) controlled flights should not be vectored into uncontrolled airspace except in the case of emergency or in order to circumnavigate severe weather (in which case the pilot should be so informed), or at the specific request of the pilot; and
- e) when an aircraft has reported unreliable directional instruments, the pilot should be requested, prior to the issuance of manoeuvring instructions, to make all turns at an agreed rate and to carry out the instructions immediately upon receipt.

6.5.2 When vectoring an IFR flight, the radar controller shall issue clearances such that the prescribed obstacle clearance will exist at all times until the aircraft reaches the point where the pilot will resume own navigation.

Note.— When an IFR flight is being vectored, the pilot is often unable to determine the aircraft's exact position and consequently the altitude which provides the required obstacle clearance.

6.5.3 Whenever possible, minimum vectoring altitudes should be sufficiently high to minimize activation of aircraft ground proximity warning systems.

Note.— Activation of such systems will induce aircraft to pull up immediately and climb steeply to avoid hazardous terrain, possibly compromising separation between aircraft.

6.5.4 States shall encourage operators to report incidents involving activations of aircraft ground proximity warning systems so that their locations can be identified and altitude, routing and/or aircraft operating procedures can be altered to prevent recurrences.

6.5.5 In terminating radar vectoring of an aircraft, the radar controller shall instruct the pilot to resume own navigation, giving the pilot the aircraft's position and appropriate instructions, as necessary, in the form prescribed in 6.4.2 b), if the current instructions had diverted the aircraft from a previously assigned route.

6.6 Navigation assistance

6.6.1 An identified aircraft observed to deviate significantly from its intended route or designated holding pattern shall be advised accordingly. Appropriate action shall also be taken if, in the opinion of the controller, such deviation is likely to affect the service being provided.

6.6.2 The pilot of an aircraft requesting navigation assistance from an air traffic control unit providing radar services shall state the reason, (e.g. to avoid areas of adverse weather or unreliable navigational instruments), and shall give as much information as possible in the circumstances.

6.7 Interruption or termination of radar service

6.7.1 An aircraft which has been informed that it is provided with radar service should be informed immediately when, for any reason, radar service is interrupted or terminated.

6.7.2 When the control of an aircraft is to be transferred from a radar controller to a non-radar controller, the radar controller shall ensure that non-radar separation is established between that aircraft and any other controlled aircraft before the transfer is effected.

6.8 Minimum levels

6.8.1 A radar controller shall at all times be in possession of full and up-to-date information regarding:

- a) established minimum flight altitudes within the area of responsibility;
- b) the lowest usable flight level or levels determined in accordance with Part II and Part III; and
- c) established minimum altitudes applicable to procedures based on tactical radar vectoring.

Note.— Criteria for the determination of minimum altitudes applicable to procedures based on tactical radar vectoring are contained in Procedures for Air Navigation Services — Aircraft Operations (PANS-OPS, Doc 8168), Volume II, Part III.

6.9 Information regarding adverse weather

6.9.1 Information that an aircraft appears likely to penetrate an area of adverse weather should be issued in sufficient time to permit the pilot to decide on an appropriate course of action, including that of requesting advice on how best to circumnavigate the adverse weather area, if so desired.

Note.— Depending on the capabilities of the radar system, areas of adverse weather may not be presented on the radar display. An aircraft's weather radar will normally provide better detection and definition of adverse weather than radar sensors in use by ATS.

6.9.2 In vectoring an aircraft for circumnavigating any area of adverse weather, the radar controller should ascertain that the aircraft can be returned to its intended or assigned flight path within the available radar coverage, and, if this does not appear possible, inform the pilot of the circumstances.

Note.— Attention must be given to the fact that under certain circumstances the most active area of adverse weather may not show on a radar display.

6.10 Reporting of significant meteorological information to meteorological offices

6.10.1 Although a radar controller is not required to keep a special watch for storm detection, etc., information on the position, intensity, extent and movement of significant weather (i.e. storms or well-defined frontal surfaces) as observed on radar displays, should, when practicable, be reported to the associated meteorological office.

7. Use of radar in the air traffic control service

Note.— The procedures in this Section are general procedures applicable when radar is used in the provision of area control service or approach control service. Additional procedures applicable in the provision of approach control service are detailed in Section 9.

7.1 Functions

7.1.1 The information presented on a radar display may be used to perform the following functions in the provision of air traffic control service:

- a) provide radar services as necessary in order to improve airspace utilization, reduce delays, provide for direct routings and more optimum flight profiles, as well as to enhance safety;
- b) provide radar vectoring to departing aircraft for the purpose of facilitating an expeditious and efficient departure flow and expediting climb to cruising level;
- c) provide radar vectoring to aircraft for the purpose of resolving potential conflicts;
- d) provide radar vectoring to arriving aircraft for the purpose of establishing an expeditious and efficient approach sequence;
- e) provide radar vectoring to assist pilots in their navigation, e.g. to or from a radio navigation aid, away from or around areas of adverse weather, etc.;
- f) provide separation and maintain normal traffic flow when an aircraft experiences communication failure within the area of the radar coverage;
- g) maintain radar monitoring of air traffic;

Note.— Where tolerances regarding such matters as adherence to track, speed or time have been prescribed by the appropriate ATS authority, deviations are not considered significant until such tolerances are exceeded.

- h) when applicable, maintain a watch on the progress of air traffic, in order to provide a non-radar controller with:
 - i) improved position information regarding aircraft under control;
 - ii) supplementary information regarding other traffic; and
 - iii) information regarding any significant deviations, by aircraft, from the terms of their respective air traffic control clearances, including their cleared routes as well as levels when appropriate.

7.2 Co-ordination of traffic under radar and non-radar control

7.2.1 Appropriate arrangements shall be made in any air traffic control unit using radar to ensure the co-ordination of traffic under radar control with traffic under non-radar

control, and to ensure the provision of adequate separation between the radar-controlled aircraft and all other controlled aircraft. To this end, close liaison shall be maintained at all times between radar controllers and non-radar controllers.

7.3 Separation application

Note.— Factors which the radar controller must take into account in determining the spacing to be applied in particular circumstances in order to ensure that the separation minimum is not infringed include aircraft relative headings and speeds, radar technical limitations, controller workload and any difficulties caused by communication congestion. Guidance material on this subject is contained in the Air Traffic Services Planning Manual (Doc 9426).

7.3.1 Except as provided for in 7.3.7, 7.3.8 and 8.3.2.1, radar separation shall only be applied between identified aircraft when there is reasonable assurance that identification will be maintained.

7.3.2 Except when transfer of radar control is to be effected, non-radar separation shall be established by a radar controller before an aircraft under radar control reaches the limits of the controller's area of responsibility, or before the aircraft leaves the area of radar coverage.

7.3.3 When authorized by the appropriate ATS authority, radar separation based on the use of RPS and/or PSR blips shall be applied so that the distance between the centres of the RPS's and/or PSR blips, representing the positions of the aircraft concerned, is never less than a prescribed minimum.

7.3.4 Radar separation based on the use of PSR blips and SSR responses shall be applied so that the distance between the centre of the PSR blip and the nearest edge of the SSR response (or the centre, when authorized by the appropriate ATS authority) is never less than a prescribed minimum.

7.3.5 Radar separation based on the use of SSR responses shall be applied so that the distance between the closest edges of the SSR responses (or the centres, when authorized by the appropriate authority) is never less than a prescribed minimum.

7.3.6 In no circumstances shall the edges of the radar position indications touch or overlap unless vertical separation is applied between the aircraft concerned, irrespective of the type of radar position indication displayed and radar separation minimum applied.

7.3.7 In the event that the radar controller has been notified of a controlled flight entering or about to enter the airspace within which radar separation is applied, but has not radar identified the aircraft, the controller may, if so prescribed by the appropriate ATS authority, continue to provide radar service to identified aircraft provided that:

- a) reasonable assurance exists that the unidentified controlled flight will be identified using SSR or the flight is being operated by an aircraft of a type which may be expected to give an adequate return on primary radar in the airspace within which radar separation is applied; and
- b) radar separation is maintained between the radar-controlled flights and any other observed radar position until either the unidentified controlled flight has been identified or non-radar separation has been established.

7.3.8 Radar separation may be applied between an aircraft taking off and a preceding departing aircraft or other radar-controlled traffic provided there is reasonable assurance that the departing aircraft will be identified within 2 km (1 NM) from the end of the runway, and that, at the time, the required separation will exist.

7.3.9 Radar separation shall not be applied between aircraft holding over the same holding point. Application of radar separation between holding aircraft and other flights shall be subject to requirements and procedures prescribed by the appropriate ATS authority.

7.4 Radar separation minima

7.4.1 Unless otherwise prescribed in accordance with 7.4.2, 7.4.3 or 7.4.4, or Part IV with respect to independent and dependent parallel approaches, the horizontal radar separation minimum shall be 9.3 km (5.0 NM).

7.4.2 The radar separation minimum in 7.4.1 may, if so prescribed by the appropriate ATS authority, be reduced, but not below:

- a) 5.6 km (3.0 NM) when radar capabilities at a given location so permit; and
- b) 4.6 km (2.5 NM) between succeeding aircraft which are established on the same final approach track within 18.5 km (10 NM) of the runway end. A reduced separation minimum of 4.6 km (2.5 NM) may be applied, provided:

- i) the average runway occupancy time of landing aircraft is proven, by means such as data collection and statistical analysis and methods based on a theoretical model, not to exceed 50 seconds;
- ii) braking action is reported as good and runway occupancy times are not adversely affected by runway contaminants such as slush, snow or ice;
- iii) a radar system with appropriate azimuth and range resolution and an update rate of 5 seconds or less is used in combination with suitable radar displays; and
- iv) the aerodrome controller is able to observe, visually or by means of surface movement radar (SMR) or a surface movement guidance and control system (SMCGS), the runway-in-use and associated exit and entry taxiways;
- v) wake turbulence radar separation minima in 7.4.4 below, or as may be prescribed by the appropriate ATS authority (e.g. for specific aircraft types), do not apply;
- vi) aircraft approach speeds are closely monitored by the controller and when necessary adjusted so as to ensure that separation is not reduced below the minimum;
- vii) aircraft operators and pilots have been made fully aware of the need to exit the runway in an expeditious manner whenever the reduced separation minimum on final approach is applied; and
- viii) procedures concerning the application of the reduced minimum are published in Aeronautical Information Publications.

7.4.3 The radar separation minimum or minima to be applied shall be prescribed by the appropriate ATS authority according to the capability of the particular radar system or sensor to accurately identify the aircraft position in relation to the centre of an RPS, PSR blip or SSR response and taking into account factors which may affect the accuracy of the radar-derived information, such as aircraft range from the radar site.

7.4.4 The following wake turbulence radar separation minima shall be applied to aircraft in the approach and departure phases of flight in the circumstances given in 7.4.4.1.

| Aircraft category | | |
|--------------------|---------------------|---|
| Preceding aircraft | Succeeding aircraft | Wake turbulence radar separation minima |
| HEAVY | HEAVY | 7.4 km (4.0 NM) |
| | MEDIUM | 9.3 km (5.0 NM) |
| | LIGHT | 11.1 km (6.0 NM) |
| MEDIUM | LIGHT | 9.3 km (5.0 NM) |

Note.— The provisions governing wake turbulence aircraft categorization are set forth in Part V, Section 16.

7.4.4.1 The minima set out in 7.4.4 shall be applied when:

- a) an aircraft is operating directly behind another aircraft at the same altitude or less than 300 m (1 000 ft) below; or
- b) both aircraft are using the same runway, or parallel runways separated by less than 760 m; or
- c) an aircraft is crossing behind another aircraft, at the same altitude or less than 300 m (1 000 ft) below.

Note.— See Figures VI-1A and VI-1B.

7.5 Transfer of radar control

7.5.1 Transfer of radar control should be effected whenever practicable so as to enable the uninterrupted provision of radar service.

7.5.2 Where SSR is used and the radar system provides for the display of radar position indications with associated radar labels, transfer of radar control of aircraft between adjacent control positions or between adjacent ATC units may be effected without prior co-ordination, provided that:

- a) updated flight plan information on the aircraft about to be transferred, including the discrete assigned SSR Code, is provided to the accepting controller prior to transfer;
- b) radar coverage provided to the accepting controller is such that the aircraft concerned is presented on the radar display before the transfer is effected and is identified on, but preferably before, receipt of the initial call;

- c) when the controllers are not physically adjacent, two-way direct speech facilities, which permit communications to be established instantaneously, are available between them at all times;

Note.— “Instantaneous” refers to communications which effectively provide for immediate access between controllers.

- d) the transfer point or points and all other conditions of application, such as direction of flight, specified levels, transfer of communication points, and especially an agreed minimum separation between aircraft, including that applicable to succeeding aircraft on the same route, about to be transferred as observed on the display, have been made the subject of specific instructions (for intra-unit transfer) or of a specific letter of agreement between two adjacent ATC units;
- e) the instructions or letter of agreement specify explicitly that the application of this type of transfer of radar control may be terminated at any time by the accepting controller, normally with an agreed advance notice;
- f) the accepting controller is kept currently informed of any level, speed or vectoring instructions given to the aircraft prior to its transfer and which modify its anticipated flight progress at the point of transfer.

7.5.3 The minimum agreed separation between aircraft about to be transferred (7.5.2 d) refers) and the advance notice (7.5.2 e) refers) shall be determined taking into account all relevant technical, operational and other circumstances. If circumstances arise in which these agreed conditions can no longer be satisfied, controllers shall revert to the procedure in 7.5.4 until the situation is resolved.

7.5.4 Where primary radar is being used, and where SSR is employed but the provisions of 7.5.2 are not applied, the transfer of radar control of aircraft between adjacent control positions or between two adjacent ATC units may be effected, provided that:

- a) radar identification has been transferred to or has been established directly by the accepting radar controller;
- b) when the radar controllers are not physically adjacent, two-way direct-speech facilities between them are at all times available which permit communications to be established instantaneously;

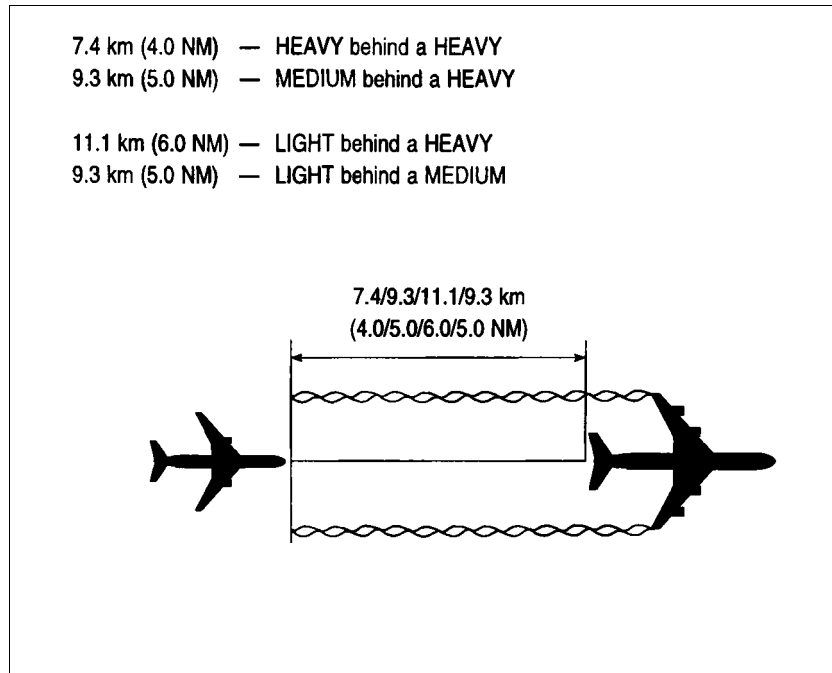

Figure VI-1A (See 7.4.4 and 7.4.4.1)

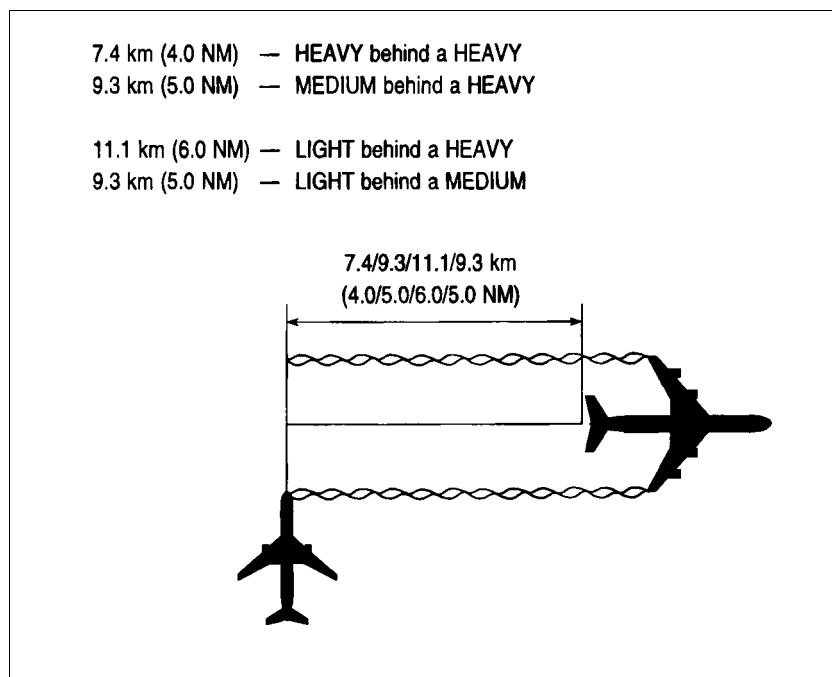

Figure VI-1B (See 7.4.4 and 7.4.4.1)

- c) radar separation from other radar-controlled flights conforms to the minima authorized for use during transfer of radar control between the radar sectors or units concerned;
- d) the accepting radar controller is informed of any level, speed or vectoring instructions applicable to the aircraft at the point of transfer;
- e) radiocommunication with the aircraft is retained by the transferring radar controller until the accepting radar controller has agreed to assume responsibility for providing radar service to the aircraft. Thereafter, the aircraft should be instructed to change over to the appropriate frequency and from that point is the responsibility of the accepting radar controller.

7.6 Speed control

7.6.1 Subject to conditions specified by the appropriate ATS authority, including consideration of aircraft performance limitations, a radar controller may, in order to facilitate radar control or to reduce the need for radar vectoring, request aircraft under radar control to adjust their speed in a specified manner. Aircraft may be requested to maintain maximum speed, minimum speed, minimum clean speed (signifying that drag-inducing devices are not deployed), minimum approach speed or a specific speed. Specific speeds should normally be expressed in multiples of 20 km/h (10 kt) based on indicated airspeed (IAS), or in multiples of 0.01 Mach when using the Mach number technique.

7.6.2 Only minor speed adjustments, of not more than ± 40 km/h (± 20 kt), should be requested of an aircraft established on intermediate and final approach. Speed control should not be applied after a point 8 km (4 NM) from the threshold on final approach.

7.6.3 Aircraft concerned should be advised as soon as speed control is no longer necessary.

8. Emergencies, hazards and equipment failures

8.1 Emergencies

8.1.1 In the event of an aircraft in, or appearing to be in, any form of emergency, every assistance shall be provided by the radar controller and the procedures prescribed herein may be varied according to the situation.

Rules of the Air and Air Traffic Services (PANS-RAC)

8.1.2 The progress of an identified aircraft in emergency shall be monitored and (whenever possible) plotted on the radar display until the aircraft passes out of radar coverage, and position information shall be provided to all air traffic services units which may be able to give assistance to the aircraft. Radar transfer to adjacent radar sectors shall also be effected when appropriate.

Note.— If the pilot of an aircraft encountering a state of emergency has previously been directed by ATC to operate the transponder on a specific code, that code will normally be maintained unless, in special circumstances, the pilot has decided or has been advised otherwise. Where ATC has not requested a code to be set, the pilot will set the transponder to Mode A Code 7700.

8.2 Collision hazard information

8.2.1 When an identified controlled flight is observed to be on a conflicting path with an unknown aircraft deemed to constitute a collision hazard, the pilot of the controlled flight shall, whenever practicable:

- a) be informed of the unknown aircraft and if so requested by the controlled flight or, if in the opinion of the radar controller the situation warrants, a course of avoiding action should be suggested; and
- b) be notified when the conflict no longer exists.

8.2.2 When an identified IFR flight operating outside controlled airspace is observed to be on a conflicting path with another aircraft, the pilot should:

- a) be informed as to the need for collision avoidance action to be initiated, and if so requested by the pilot or if, in the opinion of the radar controller, the situation warrants, a course of avoiding action should be suggested; and
- b) be notified when the conflict no longer exists.

8.2.3 Information regarding traffic on a conflicting path should be given, whenever practicable, in the following form:

- a) relative bearing of the conflicting traffic in terms of the 12-hour clock;
- b) distance from the conflicting traffic in kilometres (nautical miles);

- c) direction in which the conflicting traffic appears to be proceeding;
- d) level and type of aircraft or, if unknown, relative speed of the conflicting traffic, e.g. slow or fast.

8.2.4 SSR Mode C-derived level information, even when unverified, should be used in the provision of collision hazard information because such information, particularly if available from an otherwise unknown aircraft (e.g. a VFR flight) and given to the pilot of a known aircraft, could facilitate the location of a collision hazard.

8.2.4.1 When the Mode C-derived level information has been verified, the information shall be passed to pilots in a clear and unambiguous manner. If the level information has not been verified, the accuracy of the information should be considered uncertain and the pilot shall be informed accordingly.

8.3 Failure of equipment

8.3.1 Aircraft radio transmitter failure

8.3.1.1 If two-way communication is lost with an aircraft, the radar controller should determine whether or not the aircraft's receiver is functioning by instructing the aircraft on the frequency so far used to acknowledge by making a specified manoeuvre and by observing the aircraft's track, or by instructing the aircraft to operate IDENT or to make code changes.

Note.— Transponder equipped aircraft experiencing radio-communication failure will operate the transponder on Mode A Code 7600.

8.3.1.2 If the action prescribed in 8.3.1.1 is unsuccessful, it shall be repeated on any other available frequency on which it is believed that the aircraft might be listening.

8.3.1.3 In both the cases covered by 8.3.1.1 and 8.3.1.2, any manoeuvring instructions shall be such that the aircraft would regain its current cleared track after having complied with the instructions received.

8.3.1.4 Where it has been established by the action in 8.3.1.1 that the aircraft's radio receiver is functioning, continued control of transponder equipped aircraft where SSR is available can be effected using code changes or IDENT transmissions to obtain acknowledgement of clearances issued to the aircraft.

8.3.2 Complete aircraft communication failure

8.3.2.1 When a controlled aircraft experiencing complete communication failure is operating or expected to operate in an area and at flight levels where radar separation is applied, such separation may continue to be used. However, if the aircraft experiencing the communication failure is not identified, radar separation shall be applied between aircraft under radar control and all unidentified aircraft observed along the expected route of the aircraft with the communication failure, until such time as it is known, or can safely be assumed, that the aircraft with radio failure has passed through the airspace concerned, has landed, or has proceeded elsewhere.

8.3.3 Aircraft transponder failure in areas where the carriage of a functioning transponder is mandatory

8.3.3.1 When an aircraft experiencing transponder failure after departure is operating or expected to operate in an area where the carriage of a functioning transponder with specified capabilities is mandatory, the ATC units concerned should endeavour to provide for continuation of the flight to the aerodrome of first intended landing in accordance with the flight plan. However, in certain traffic situations, either in terminal areas or en-route, continuation of the flight may not be possible, particularly when failure is detected shortly after take-off. The aircraft may then be required to return to the departure aerodrome or to land at the nearest suitable aerodrome acceptable to the operator concerned and to ATC.

8.3.3.2 In case of a transponder failure which is detected before departure from an aerodrome where it is not practicable to effect a repair, the aircraft concerned should be permitted to proceed, as directly as possible, to the nearest suitable aerodrome where repair can be made. When granting clearance to such aircraft, ATC should take into consideration the existing or anticipated traffic situation and may have to modify the time of departure, flight level or route of the intended flight. Subsequent adjustments may become necessary during the course of the flight.

8.4 Radar equipment failure

8.4.1 In the event of complete failure of the radar equipment except for air-ground communications, the radar controller shall:

- a) plot the positions of all aircraft already identified and, in conjunction with the non-radar controller when

applicable, take the necessary action to establish non-radar separation between the aircraft;

and when relevant:

- b) request the appropriate non-radar controller to assume control of the traffic affected;
- c) instruct aircraft to communicate with the appropriate non-radar controller for further instructions.

8.4.2 As an emergency measure, use of flight levels spaced by half the applicable vertical separation minimum may be resorted to temporarily if standard non-radar separation cannot be provided immediately.

8.4.3 Except when there is assurance that the complete radar equipment failure will be of a very limited duration, steps should be taken to limit the number of aircraft permitted to enter the area to that which can be safely handled without the use of radar.

8.5 Ground radio failure

8.5.1 In the event of complete failure of the ground radio equipment used for radar control, the radar controller shall, unless able to continue to provide the radar service by means of other available communication channels, proceed as set forth in 8.4.1 a) and b).

8.5.2 Where the provisions in 8.4.1 are not applicable, the controller shall:

- a) without delay inform all adjacent control positions or ATC units, as applicable, of the failure;
- b) appraise such positions or units of the current traffic situation;
- c) request their assistance, in respect of aircraft which may establish communications with those positions or units, in establishing radar or non-radar separation between and maintaining control of such aircraft; and
- d) instruct adjacent control positions or ATC units to hold or reroute all controlled flights outside the area of responsibility of the position or ATC unit that has experienced the failure until such time that the provision of normal services can be resumed.

8.5.3 In order to reduce the impact of complete ground radio equipment failure on the safety of air traffic, the appro-

priate ATS authority should establish contingency procedures to be followed by control positions and ATC units in the event of such failures. Where feasible and practicable, such contingency procedures should provide for the delegation of control to an adjacent control position or ATC unit in order to permit a minimum level of services to be provided as soon as possible, following the ground radio failure and until normal operations can be resumed.

9. Use of radar in the approach control service

9.1 General provisions

9.1.1 Radar systems used in the provision of approach control service shall be appropriate to the functions and level of service to be provided.

9.1.2 Radar systems used to monitor parallel ILS approaches shall meet the requirements for such operations specified in Part IV.

9.2 Functions

9.2.1 The information presented on a radar display may be used to perform the following additional functions in the provision of approach control service:

- a) provide radar vectoring of arriving traffic on to pilot-interpreted final approach aids;
- b) provide radar monitoring of parallel ILS approaches and instruct aircraft to take appropriate action in the event of possible or actual penetrations of the no transgression zone (NTZ);

Note.— See Part IV, Section 13.

- c) provide radar vectoring of arriving traffic to a point from which a visual approach can be completed;
- d) provide radar vectoring of arriving traffic to a point from which a precision radar approach or a surveillance radar approach can be made;
- e) provide radar monitoring of other pilot-interpreted approaches;

- f) in accordance with prescribed procedures, conduct:
 - i) surveillance radar approaches;
 - ii) precision radar (PAR) approaches; and
- g) provide radar separation between:
 - i) succeeding departing aircraft;
 - ii) succeeding arriving aircraft; and
 - iii) a departing aircraft and a succeeding arriving aircraft.

9.3 General approach radar procedures

9.3.1 The appropriate ATS authority shall establish procedures to ensure that the aerodrome controller is kept informed of the sequence of arriving aircraft, as well as any instructions and restrictions which have been issued to such aircraft in order to maintain separation after transfer of control to the aerodrome controller.

9.3.2 Prior to, or upon commencement of, radar vectoring for approach, the pilot shall be advised of the type of approach as well as the runway to be used.

9.3.3 The radar controller shall advise an aircraft being radar vectored for an instrument approach of its position at least once prior to commencement of final approach.

9.3.4 When giving distance information, the radar controller shall specify the point or navigation aid to which the information refers.

9.3.5 The initial and intermediate approach phases of an approach executed under the direction of a radar controller comprise those parts of the approach from the time radar vectoring is initiated for the purpose of positioning the aircraft for a final approach, until the aircraft is on final approach and:

- a) established on the final approach path of a pilot-interpreted aid; or
- b) reports that it is able to complete a visual approach; or
- c) ready to commence a surveillance radar approach; or
- d) transferred to the precision radar approach controller.

9.3.6 Aircraft vectored for final approach should be given a heading or a series of headings calculated to close with the final approach track. The final vector shall enable the aircraft to be established in level flight on the final approach track prior to intercepting the specified or nominal glide path if an MLS, ILS or radar approach is to be made, and should provide an intercept angle with the final approach track of 45 degrees or less.

Note.— See Part IV, Section 13.2 concerning radar vectoring of independent parallel approaches.

9.3.7 Whenever an aircraft is assigned a radar vector which will take it through the final approach track, it should be advised accordingly, stating the reason for the vector.

9.4 Vectoring to pilot-interpreted final approach aid

9.4.1 An aircraft vectored to intercept a pilot-interpreted final approach aid shall be instructed to report when established on the final approach track. Clearance for the approach should be issued prior to when the aircraft reports established, unless circumstances preclude the issuance of the clearance at such time. Radar vectoring will normally terminate at the time the aircraft leaves the last assigned heading to intercept the final approach track.

9.4.2 The radar controller shall be responsible for maintaining radar separation between succeeding aircraft on the same final approach, except that the responsibility may be transferred to the aerodrome controller in accordance with procedures prescribed by the appropriate ATS authority and provided radar information is available to the aerodrome controller.

9.4.3 Transfer of control of succeeding aircraft on final approach from the radar controller to the aerodrome controller shall be effected in accordance with procedures prescribed by the appropriate ATS authority.

9.4.4 Transfer of communications to the aerodrome controller should be effected at such a point or time that clearance to land or alternative instructions can be issued to the aircraft in a timely manner.

9.5 Vectoring for visual approach

Note.— See also Part IV, Section 9.

9.5.1 The radar controller may initiate radar vectoring of an aircraft for visual approach provided the reported

ceiling is above the minimum altitude applicable to radar vectoring and meteorological conditions are such that, with reasonable assurance, a visual approach and landing can be completed.

9.5.2 Clearance for visual approach shall be issued only after the pilot has reported the aerodrome or the preceding aircraft in sight, at which time radar vectoring would normally be terminated.

9.6 Radar approaches

9.6.1 General provisions

9.6.1.1 During the period that a radar controller is engaged in giving surveillance radar or precision radar approaches, he or she should not be responsible for any duties other than those directly connected with such approaches.

9.6.1.2 Radar controllers conducting radar approaches shall be in possession of information regarding the obstacle clearance altitudes/heights established for the types of approach to be conducted.

9.6.1.3 Prior to commencement of a radar approach, the aircraft shall be informed of:

- a) the runway to be used;
- b) the applicable obstacle clearance altitude/height;
- c) the angle of the nominal glide path and, if so prescribed by the appropriate ATS authority or requested by the aircraft, the approximate rate of descent to be maintained;

Note.— See the Air Traffic Services Planning Manual (Doc 9426) regarding calculation of approximate rates of descent.

- d) the procedure to be followed in the event of radio-communication failure, unless the procedure has been published in Aeronautical Information Publications.

9.6.1.4 When a radar approach cannot be continued due to any circumstance, the aircraft should be immediately informed that a radar approach or continuation thereof is not possible. The approach should be continued if this is possible using non-radar facilities or if the pilot reports that the approach can be completed visually; otherwise an alternative clearance should be given.

Rules of the Air and Air Traffic Services (PANS-RAC)

9.6.1.5 Aircraft making a radar approach should be reminded, when on final approach, to check that the wheels are down and locked.

9.6.1.6 Unless otherwise prescribed by the appropriate ATS authority, the radar controller should notify the aerodrome controller or, when applicable, the non-radar controller when an aircraft making a radar approach is approximately 15 km (8 NM) from touchdown. If landing clearance is not received at this time, a subsequent notification should be made at approximately 8 km (4 NM) from touchdown and landing clearance requested.

9.6.1.7 Clearance to land or any alternative clearance received from the aerodrome controller or, when applicable, the non-radar controller should normally be passed to the aircraft before it reaches a distance of 4 km (2 NM) from touchdown.

9.6.1.8 An aircraft making a radar approach should:

- a) be directed to execute a missed approach in the following circumstances:
 - i) when the aircraft appears to be dangerously positioned on final approach; or
 - ii) for reasons involving traffic conflicts; or
 - iii) if no clearance to land has been received from the non-radar controller by the time the aircraft reaches a distance of 4 km (2 NM) from touchdown or such other distance as has been agreed with the aerodrome control tower; or
 - iv) on instructions by the aerodrome controller; or
- b) be advised to consider executing a missed approach in the following circumstances:
 - i) when the aircraft reaches a position from which it appears that a successful approach cannot be completed; or
 - ii) if the aircraft is not visible on the radar display for any significant interval during the last 4 km (2 NM) of the approach; or
 - iii) if the position or identification of the aircraft is in doubt during any portion of the final approach.

In all such cases, the reason for the instruction or the advice should be given to the pilot.

9.6.1.9 Unless otherwise required by exceptional circumstances, radar instructions concerning a missed approach should be in accordance with the prescribed missed approach procedure and should include the level to which the aircraft is to climb and heading instructions to keep the aircraft within the missed approach area during the missed approach procedure.

9.7 Final approach procedures

9.7.1 Surveillance radar approach

9.7.1.1 A final approach using solely surveillance radar should not be carried out if precision approach radar is available, unless meteorological conditions are such as to indicate with reasonable certainty that a surveillance radar approach can be completed successfully.

9.7.1.2 A surveillance radar approach shall only be performed with equipment suitably sited and a radar display specifically marked to provide information on position relative to the extended centre line of the runway to be used and distance from touchdown, and which is specifically approved for the purpose by the appropriate ATS authority.

9.7.1.3 When conducting a surveillance radar approach, the radar controller shall comply with the following:

- a) at or before the commencement of the final approach, the aircraft shall be informed of the point at which the surveillance radar approach will be terminated;
- b) the aircraft shall be informed when it is approaching the point at which it is computed that descent should begin, and just before reaching that point it shall be informed of the obstacle clearance altitude/height and instructed to descend and check the applicable minima;
- c) azimuth instructions shall be given in accordance with the precision approach technique (see 9.7.2.4);
- d) except as provided in 9.7.1.4, distance from touchdown shall normally be passed at every 2 km (each NM);

- e) pre-computed levels through which the aircraft should be passing to maintain the glide path shall also be transmitted at every 2 km (each NM) at the same time as the distance;
- f) the surveillance radar approach shall be terminated:
 - i) at a distance of 4 km (2 NM) from touchdown, except as provided in 9.7.1.4; or
 - ii) before the aircraft enters an area of continuous radar clutter; or
 - iii) when the pilot reports that a visual approach can be effected;

whichever is the earliest.

9.7.1.4 When, as determined by the appropriate ATS authority, the accuracy of the radar equipment permits, surveillance radar approaches may be continued to the threshold of the runway, or to a prescribed point less than 4 km (2 NM) from touchdown, in which case:

- a) distance and level information shall be given at each km (each half NM);
- b) transmission should not be interrupted for intervals of more than five seconds while the aircraft is within a distance of 8 km (4 NM) from touchdown;
- c) the radar controller should not be responsible for any duties other than those directly connected with a particular approach.

9.7.1.5 Levels through which the aircraft should pass to maintain the required glide path, and the associated distances from touchdown, shall be pre-computed and displayed in such a manner as to be readily available to the radar controller.

Note.— See the Air Traffic Services Planning Manual (Doc 9426) regarding pre-computation of levels.

9.7.2 Precision radar approach

9.7.2.1 Duties of precision approach controller

9.7.2.1.1 During the period the radar controller is engaged in giving a precision approach, the controller should not be responsible for any duties other than those directly connected with that particular approach.

9.7.2.2 *Transfer of control*

9.7.2.2.1 Aircraft to be provided with a precision radar approach shall have been transferred to the radar controller in charge of the precision approach at a distance of not less than 2 km (1 NM) from the point of interception of the glide path, unless otherwise provided by the appropriate ATS authority.

9.7.2.3 *Communications*

9.7.2.3.1 When control of the aircraft is assumed by the radar controller in charge of the precision approach, a communications check shall be made on the channel to be used during the precision approach and the pilot shall be advised that no further acknowledgement of transmission is required. Thereafter, transmission should not be interrupted for intervals of more than five seconds while the aircraft is on final approach.

9.7.2.4 *Azimuth information and corrections*

9.7.2.4.1 The pilot shall be informed at regular intervals of the aircraft's position in relation to the extended centre line of the runway. Heading corrections shall be given as necessary to bring the aircraft back on to the extended centre line.

9.7.2.4.2 In the case of azimuth deviations, the pilot should not take corrective action unless specifically instructed to do so.

9.7.2.5 *Elevation information and adjustments*

9.7.2.5.1 The aircraft shall be informed when it is approaching the point of interception of the glide path and, just before intercepting the glide path, it shall be instructed to begin its descent and to check the applicable decision altitude/height. Thereafter, the aircraft shall be informed at regular intervals of its position in relation to the glide path. When no corrections are required, the aircraft should be informed at regular intervals that it is on the glide path. Deviations from the glide path shall be given to the aircraft, together with instructions to adjust the rate of descent if the corrective action taken by the aircraft does not appear to be sufficient. The aircraft shall be informed when it starts to regain the glide path, and immediately before it reaches the glide path.

9.7.2.5.2 In the case of deviations from the glide path, the pilot should take corrective action on the basis of the information given by the controller, even though not specifically instructed to do so.

9.7.2.5.3 Prior to the aircraft reaching a point 4 km (2 NM) from touchdown, or a greater distance as necessary for faster aircraft, a certain degree of tolerance should be allowed with regard to deviations from the glide path, and elevation information need not specify the actual number of metres (or feet) above or below the glide path unless it is required to emphasize the rate of change or the extent of the displacement. Thereafter, any deviations from the glide path should be given to the aircraft, preferably in terms of specific distances (metres or feet) above or below the glide path. The use of emphasis in the manner in which the information is transmitted should normally be sufficient to expedite action by the pilot when necessary (e.g. "*STILL* 20 metres (60 feet) too low").

9.7.2.5.4 Should the elevation element fail during a precision radar approach, the radar controller shall inform the aircraft immediately. If possible, the controller shall change to a surveillance radar approach, informing the aircraft of the revised obstacle clearance altitude/height. Alternatively, instructions should be given for a missed approach.

9.7.2.6 *Distance information*

9.7.2.6.1 The distance from touchdown should be transmitted at intervals of 2 km (1 NM) until the aircraft reaches a distance of 8 km (4 NM) from touchdown. Thereafter distance information should be transmitted at more frequent intervals, priority being given, however, to the provision of azimuth and elevation information and guidance.

9.7.2.7 *Termination of a precision radar approach*

9.7.2.7.1 A precision radar approach is terminated when the aircraft reaches the point at which the glide path intercepts the obstacle clearance altitude/height. Nevertheless, information shall continue to be given until the aircraft is over the threshold, or at such distance therefrom as may be specified by the appropriate ATS authority, taking into account the capability of the equipment concerned. The approach may be monitored to touchdown and information may continue to be provided as necessary at the discretion of the radar controller in charge of the precision approach in which case the aircraft shall be informed when it is over the threshold.

9.7.2.8 *Missed approaches*

9.7.2.8.1 When information provided by the elevation element indicates that the aircraft may be initiating a missed approach, the radar controller shall take the following action:

- a) when there is sufficient time to obtain a reply from the pilot (e.g. when the aircraft is more than 4 km (2 NM) from touchdown), the radar controller shall transmit the aircraft's height above the glide path and ask if the pilot intends to make a missed approach. If this is confirmed by the pilot, the radar controller shall pass missed approach instructions (see 9.6.1.8);
- b) when there is not sufficient time to obtain a reply from the pilot (e.g. when the aircraft is at 4 km (2 NM) or less from touchdown) the precision approach should be continued, emphasizing the aircraft's displacement, and terminated at the normal termination point. If it is apparent from elevation information that the aircraft is making a missed approach, either before or after the normal termination point, the radar controller shall pass missed approach instructions (see 9.6.1.8).

10. Use of radar in the aerodrome control service

10.1 Surveillance radar

10.1.1 When authorized by and subject to conditions prescribed by the appropriate ATS authority, surveillance radar may be used in the provision of aerodrome control service to perform the following functions:

- a) radar monitoring of aircraft on final approach;
- b) radar monitoring of other aircraft in the vicinity of the aerodrome;
- c) establishing radar separation between succeeding departing aircraft; and
- d) providing navigation assistance to VFR flights.

10.1.2 Special VFR flights shall not be radar vectored unless special circumstances, such as emergencies, dictate otherwise.

10.1.3 Caution shall be exercised when radar vectoring VFR flights so as to ensure that the aircraft concerned does not inadvertently enter instrument meteorological conditions.

10.1.4 In prescribing conditions and procedures for the use of radar in the provision of aerodrome control service, the

appropriate ATS authority shall ensure that the availability and use of radar information will not be detrimental to visual observation of aerodrome traffic.

Note.— Control of aerodrome traffic is in the main based on visual observation of the manoeuvring area and the vicinity of the aerodrome by the aerodrome controller.

10.2 Use of surface movement radar

Note.— Requirements concerning the provision of SMR are contained in Annex 14, Volume I, Chapter 8. Guidance material on the use of SMR is contained in the Air Traffic Services Planning Manual (Doc 9426), Part II.

10.2.1 General provisions

10.2.1.1 The use of surface movement radar (SMR) should be related to the operational conditions and requirements of the particular aerodrome (i.e. visibility conditions, traffic density and aerodrome layout).

10.2.1.2 SMR systems shall to the extent possible enable the detection and display of the movement of all aircraft and vehicles on the manoeuvring area in a clear and unambiguous manner.

10.2.1.3 Aircraft and vehicle radar position indications may be displayed in symbolic or non-symbolic form. Where radar labels are available for display, the capability should be provided for inclusion of aircraft and vehicle identification by manual or automated means.

10.2.2 Functions

10.2.2.1 SMR should be used to augment visual observation of traffic on the manoeuvring area and to provide surveillance of traffic on those parts of the manoeuvring area which cannot be observed visually.

10.2.2.2 The information displayed on an SMR display may be used to assist in:

- a) monitoring of aircraft and vehicles on the manoeuvring area for compliance with clearances and instructions;
- b) determining that a runway is clear of traffic prior to a landing or take-off;
- c) providing information on essential local traffic on or near the manoeuvring area;

- d) determining the location of aircraft and vehicles on the manoeuvring area;
- e) providing directional taxi information to aircraft when requested by the pilot or deemed necessary by the controller. Except under special circumstances, e.g. emergencies, such information should not be issued in the form of specific heading instructions; and
- f) providing assistance and advice to emergency vehicles.

10.2.3 Identification of aircraft

10.2.3.1 Where SMR is used, aircraft may be identified by one or more of the following procedures:

- a) by correlating a particular radar position indication with:
 - i) an aircraft position visually observed by the controller;
 - ii) an aircraft position reported by the pilot; or
 - iii) an identified radar position indication displayed on a surveillance radar display;
- b) by transfer of radar identification when authorized by the appropriate ATS authority; and
- c) by automated identification procedures when authorized by the appropriate ATS authority.

11. Use of radar in the flight information service

Note.— The use of radar in the provision of flight information service does not relieve the pilot-in-command of an aircraft of any responsibilities, including the final decision regarding any suggested alteration of the flight plan.

11.1 Functions

11.1.1 The information presented on a radar display may be used to provide identified aircraft with:

- a) information regarding any aircraft observed to be on a conflicting path with the radar-identified aircraft and suggestions or advice regarding avoiding action;
- b) information on the position of significant weather and, as practicable, advice to the aircraft on how best to circumnavigate any such areas of adverse weather (see 6.9.2, Note);
- c) information to assist the aircraft in its navigation.

11.1.2 *Radar air traffic advisory service.* When radar is used in the provision of air traffic advisory service, the procedures in Section 2 for the use of radar in the air traffic control service shall be applied subject to the conditions and limitations governing the provision of air traffic advisory service, as set forth in Part VII, 1.4.

PART VII. FLIGHT INFORMATION SERVICE AND ALERTING SERVICE

1. Flight information service

1.1 Recording and transmission of information on the progress of flights

1.1.1 Information on the actual progress of flights, including those of heavy or medium unmanned free balloons, under neither air traffic control service nor air traffic advisory service shall be:

- a) recorded by the air traffic services unit serving the flight information region within which the aircraft is flying in such a manner that it is available for reference and in case it is requested for search and rescue action;
- b) transmitted by the air traffic services unit receiving the information to other air traffic services units concerned, when so required in accordance with Part VIII, 2.2.

1.2 Transfer of responsibility for the provision of flight information service

1.2.1 The responsibility for the provision of flight information service to a flight normally passes from the appropriate ATS unit in a flight information region to the appropriate ATS unit in the adjacent flight information region at the time of crossing the common flight information region boundary. However, when co-ordination is required in accordance with Part VIII, 2.1, but communication facilities are inadequate, the former ATS unit shall, as far as practicable, continue to provide flight information service to the flight until it has established two-way communication with the appropriate ATS unit in the flight information region it is entering.

1.3 Transmission of information

1.3.1 Means of transmission

1.3.1.1 Except as provided in 1.3.2.1, information shall be disseminated to aircraft by one or more of the following means as determined by the appropriate ATS authority:

- a) the preferred method of directed transmission on the initiative of the appropriate ATS unit to an aircraft, ensuring that receipt is acknowledged; or
- b) a general call, unacknowledged transmission to all aircraft concerned; or
- c) broadcast; or
- d) data link.

Note.— It should be recognized that in certain circumstances, e.g. during the last stages of a final approach, it may be impracticable for aircraft to acknowledge directed transmissions.

1.3.1.2 The use of general calls shall be limited to cases where it is necessary to disseminate essential information to several aircraft without delay, e.g. the sudden occurrence of hazards, a change of the runway-in-use, or the failure of a key approach and landing aid.

1.3.2 Transmission of special air-reports, SIGMET and AIRMET information

1.3.2.1 Appropriate SIGMET and AIRMET information, as well as special air-reports which have not been used for the preparation of a SIGMET, shall be disseminated to aircraft by one or more of the means specified in 1.3.1.1 above as determined on the basis of regional air navigation agreements.

1.3.2.2 The special air-report, SIGMET and AIRMET information to be passed to aircraft on ground initiative should cover a portion of the route up to one hour's flying time ahead of the aircraft except when another period has been determined on the basis of regional air navigation agreements.

1.3.3 Transmission of information concerning volcanic activity

1.3.3.1 Information concerning pre-eruption volcanic activity, volcanic eruptions and volcanic ash clouds shall be disseminated to aircraft by one or more of the means specified in 1.3.1.1 above as determined on the basis of regional air navigation agreements.

1.3.4 *Transmission of information concerning radioactive materials and toxic chemical "clouds"*

1.3.4.1 Information on the release into the atmosphere of radioactive materials or toxic chemicals which could affect airspace within the area of responsibility of the ATS unit shall be transmitted to aircraft by one or more of the means specified in 1.3.1.1 above.

1.3.5 *Transmission of selected special reports and amended aerodrome forecasts*

1.3.5.1 Selected special reports and amended aerodrome forecasts shall be transmitted on request and supplemented by:

- a) directed transmission from the appropriate air traffic services unit of selected special reports and amended aerodrome forecasts for the departure, destination and its alternate aerodromes, as listed in the flight plan; or
- b) a general call on appropriate frequencies for the unacknowledged transmission to affected aircraft of selected special reports and amended aerodrome forecasts; or
- c) continuous or frequent broadcast of current aerodrome reports and forecasts in areas determined on the basis of regional air navigation agreements where traffic congestion dictates.

1.3.5.2 The passing of amended aerodrome forecasts to aircraft on the initiative of the appropriate air traffic services unit should be limited to that portion of the flight where the aircraft is within a specified time from the aerodrome of destination, such time being established on the basis of regional air navigation agreements.

1.3.6 *Transmission of information on heavy or medium unmanned free balloons*

1.3.6.1 Appropriate information on heavy or medium unmanned free balloons shall be disseminated to aircraft by one or more of the means specified in 1.3.1.1 above.

1.3.7 *Transmission of information to supersonic aircraft*

1.3.7.1 The following information shall be available at appropriate area control centres or flight information centres for aerodromes determined on the basis of regional air navigation

Rules of the Air and Air Traffic Services (PANS-RAC)

agreements and shall be transmitted on request to supersonic aircraft prior to commencement of deceleration/descent from supersonic cruise:

- a) current meteorological reports and forecasts, except that where communications difficulties are encountered under conditions of poor propagation, the elements transmitted may be limited to:
 - i) mean surface wind, direction and speed (including gusts);
 - ii) visibility or runway visual range;
 - iii) amount and height of base of low clouds;
 - iv) other significant information;

Note.— See Part IX, 4.3.2.3.8.
- v) if appropriate, information regarding expected changes;
- b) operationally significant information on the status of facilities relating to the runway in use, including the precision approach category in the event that the lowest approach category promulgated for the runway is not available;
- c) sufficient information on the runway surface conditions to permit assessment of the runway braking action.

1.4 Air traffic advisory service

1.4.1 *Objective and basic principles*

1.4.1.1 The objective of the air traffic advisory service is to make information on collision hazards more effective than it would be in the mere provision of flight information service. It may be provided to aircraft conducting IFR flights in advisory airspace or on advisory routes (Class F airspace). Such areas or routes will be specified by the State concerned.

1.4.1.2 Taking into account the consideration detailed in 2.4 of Annex 11, air traffic advisory service should only be implemented where the air traffic services are inadequate for the provision of air traffic control and the limited advice on collision hazards otherwise provided by flight information service will not meet the requirement. Where air traffic advisory service is implemented, this should be considered normally as a temporary measure only until such time as it can be replaced by air traffic control service.

1.4.1.3 Air traffic advisory service does not afford the degree of safety and cannot assume the same responsibilities as air traffic control service in respect of the avoidance of collisions, since information regarding the disposition of traffic in the area concerned available to the unit providing air traffic advisory service may be incomplete. To make this quite clear, air traffic advisory service does not deliver “clearances” but only “advisory information” and it uses the word “advise” or “suggest” when a course of action is proposed to an aircraft.

Note.— See 1.4.2.2.

1.4.2 Aircraft

1.4.2.1 Aircraft using the air traffic advisory service

1.4.2.1.1 IFR flights electing to use or required by the appropriate ATS authority on the basis of regional air navigation agreements to use the air traffic advisory service when operating within Class F airspace are expected to comply with the same procedures as those applying to controlled flights except that:

- a) the flight plan and changes thereto are not subjected to a clearance, since the unit furnishing air traffic advisory service will only provide advice on the presence of essential traffic or suggestions as to a possible course of action;

Note 1.— It is assumed that a pilot will not effect a change in the current flight plan until he has notified the intended change to the appropriate ATS unit, and, if practicable, has received acknowledgement or relevant advice.

Note 2.— When a flight is operating or about to operate in a control area to continue eventually into an advisory area or along an advisory route, a clearance may be issued for the whole route, but the clearance as such, or revisions thereto, applies only to those portions of the flight conducted within control areas and control zones (3.7.3.4 of Annex 11). Advice or suggestions would be provided as necessary for the remaining portion of the route.

- b) it is for the aircraft to decide whether or not it will comply with the advice or suggestion received and to inform the unit providing air traffic advisory service, without delay, of its decision;

- c) air-ground contacts shall be made with the air traffic services unit designated to provide air traffic advisory service within the advisory airspace or portion thereof.

Note.— See Part II, 8.2, for procedures governing submission of a flight plan.

1.4.2.2 Aircraft not using the air traffic advisory service

1.4.2.2.1 Aircraft wishing to conduct IFR flights within advisory airspace, but not electing to use the air traffic advisory service, shall nevertheless submit a flight plan, and notify changes made thereto to the unit providing that service.

Note.— See Part II, 8.2, for procedures governing submission of a flight plan.

1.4.2.2.2 IFR flights intending to cross an advisory route should do so as nearly as possible at an angle of 90 degrees to the direction of the route and at a level, appropriate to its track, selected from the tables of cruising levels prescribed for use by IFR flights operating outside controlled airspace.

1.4.3 Air traffic services units

Note.— Efficiency of air traffic advisory service will depend largely on the procedures and practices in use. Their establishment in line with the organization, procedures and equipment of area control service, taking into account the basic differences of the two services, as indicated in 1.4.2.1.1, will help to ensure a high degree of efficiency and promote uniformity in the various provisions of air traffic advisory service. For example, exchange of information by the units concerned on the progress of an aircraft from one advisory area into an adjacent control area or terminal control area, and vice versa, will help to relieve pilots from repeating details of their flight plans already filed; also, use of standard air traffic control phraseology, preceded by the word “suggest” or “advise”, will facilitate the pilot’s understanding of air traffic advisory service intelligence.

1.4.3.1 An air traffic services unit providing air traffic advisory service shall:

1.4.3.1.1 Advise the aircraft to depart at the time specified and to cruise at the levels indicated in the flight plan if it does not foresee any conflict with other known traffic.

1.4.3.1.2 Suggest to aircraft a course of action by which a potential hazard may be avoided, giving priority to an

aircraft already in advisory airspace over other aircraft desiring to enter such advisory airspace.

1.4.3.1.3 *Pass* to aircraft traffic information comprising the same information as that prescribed for area control service.

1.4.3.2 The criteria used as a basis for action under 1.4.3.1.2 and 1.4.3.1.3 should be at least those laid down for aircraft operating in controlled airspace and should take into account the limitations inherent in the provision of air traffic advisory service, navigation facilities and air-ground communications prevailing in the Region.

2. Alerting service

2.1 Aircraft

Note.— Whenever applied, the procedures for the provision of air traffic control service or air traffic advisory service take the place of the following procedures, except when relevant procedures do not call for more than hourly position reports, in which case the Operations normal procedure applies.

2.1.1 When so required by the appropriate ATS authority to facilitate the provision of alerting and search and rescue services, an aircraft, prior to and when operating, within or into designated areas or along designated routes, shall comply with the provisions detailed in Annex 2, Chapter 3, concerning the submission, completion, changing and closing of a flight plan.

2.1.2 In addition to the above, aircraft equipped with suitable two-way radiocommunications shall report during the period twenty to forty minutes following the time of last contact, whatever the purpose of such contact, merely to indicate that the flight is progressing according to plan, such report to comprise identification of the aircraft and the words “Operations normal” or the signal QRU.

2.1.3 The “Operations normal” message shall be transmitted air-ground to an appropriate air traffic services unit (e.g. normally to the aeronautical telecommunication station serving the air traffic services unit in charge of the flight information region in which the aircraft is flying, otherwise to another aeronautical telecommunication station to be retransmitted as required to the air traffic services unit in charge of the flight information region).

Rules of the Air and Air Traffic Services (PANS-RAC)

2.1.4 It may be advisable, in case of a SAR operation of a substantial duration, to promulgate by NOTAM the lateral and vertical limits of the area of SAR action, and to warn aircraft not engaged in actual SAR operations and not controlled by air traffic control to avoid such areas unless otherwise authorized by the appropriate ATS unit.

2.2 Air traffic services units

2.2.1 When no report from an aircraft has been received within a reasonable period of time (which may be a specified interval prescribed on the basis of regional air navigation agreements) after a scheduled or expected reporting time, the ATS unit shall, within the stipulated period of thirty minutes, endeavour to obtain such report in order to be in a position to apply the provisions relevant to the “Uncertainty Phase” (Annex 11, 5.2.1 refers) should circumstances warrant such application.

2.2.2 When alerting service is required in respect of a flight operated through more than one flight information region or control area, and when the position of the aircraft is in doubt, responsibility for co-ordinating such service shall rest with the ATS unit of the flight information region or control area:

- 1) within which the aircraft was flying at the time of last air-ground radio contact;
- 2) that the aircraft was about to enter when last air-ground contact was established at or close to the boundary of two flight information regions or control areas;
- 3) within which the aircraft’s intermediate stop or final destination point is located:
 - a) if the aircraft was not equipped with suitable two-way radiocommunication equipment; or
 - b) was not under obligation to transmit position reports.

2.2.3 The unit responsible for alerting service, in accordance with 2.2.2, shall

- notify units providing alerting service in other affected flight information regions or control areas of the emergency phase or phases, in addition to notifying the rescue co-ordination centre associated with it;

- request those units to assist in the search for any useful information pertaining to the aircraft presumed to be in an emergency, by all appropriate means and especially those indicated in 5.3 of Annex 11 (Use of communication facilities);
- collect the information gathered during each phase of the emergency and, after verifying it as necessary, transmit it to the rescue co-ordination centre;

- announce the termination of the state of emergency as circumstances dictate.

2.2.4 In obtaining the necessary information as required under 5.2.2.1 of Annex 11, attention shall particularly be given to informing the relevant rescue co-ordination centre of the distress frequencies available to survivors, as listed in Item 19 of the flight plan but not normally transmitted.

PART VIII. CO-ORDINATION

1. General

1.1 In circumstances where an aircraft is experiencing an emergency or has declared minimum fuel, or in any other situation wherein the safety of the aircraft is not assured, the type of emergency and the circumstances experienced by the aircraft shall be included in the co-ordination message.

2. Co-ordination in respect of the provision of flight information service and alerting service

2.1 Where this is deemed necessary by the appropriate ATS authority or authorities, co-ordination between ATS units providing flight information service in adjacent FIRs shall be effected in respect of IFR and VFR flights, in order to ensure continued flight information service to such aircraft in specified areas or along specified routes. Such co-ordination shall be effected in accordance with an agreement between the ATS units concerned.

2.2 Where co-ordination of flights is effected in accordance with 2.1 above, this shall include transmission of the following information on the flight concerned:

- a) appropriate items of the current flight plan; and
- b) the time at which last contact was made with the aircraft concerned.

2.3 This information shall be forwarded to the air traffic services unit in charge of the next flight information region in which the aircraft will operate prior to the aircraft entering such flight information region.

2.4 When so required by agreement between the appropriate ATS authorities to assist in the identification of strayed or unidentified aircraft and thereby eliminate or reduce the need for interception, flight plan and flight progress information for flights along specified routes or portions of routes in close proximity to flight information region boundaries shall also be provided to the air traffic services units in charge of the flight information regions adjacent to such routes or portions of routes.

3. Co-ordination in respect of the provision of air traffic advisory service

3.1 ATS units providing air traffic advisory service shall apply the co-ordination procedures specified in Section 4 below with respect to such aircraft having elected to use this type of service.

4. Co-ordination in respect of the provision of air traffic control service

4.1 Authority

4.1.1 Approach control offices and aerodrome control towers shall observe the co-ordination instructions issued by the appropriate area control centre. Aerodrome control towers shall, in addition, observe the co-ordination instructions issued by the appropriate approach control office.

4.2 Co-ordination between units providing area control service within contiguous control areas

4.2.1 Area control centres shall forward from centre to centre, as the flight progresses, necessary flight plan and control information.

Note.— See also 2.4.

4.2.2 The information specified in 4.2.1 shall be transmitted in sufficient time to permit reception and analysis of the data by the receiving centre and necessary co-ordination between the two centres concerned.

Note.— See Part IX and Appendix 3 for details regarding messages, their content and time of transmission.

4.2.3 If the departure aerodrome of an aircraft is not a sufficient distance from the boundary of an adjacent control area to permit transmission of the necessary flight plan and control information to the accepting centre after take-off and

allow adequate time for reception, analysis and co-ordination, the transferring centre shall, prior to clearing the aircraft, forward the data required by 4.2.1 to the accepting centre together with a request for acceptance in accordance with 4.2.5.

4.2.3.1 In the case of an aircraft in flight requiring an initial clearance at a similar distance from the boundary of an adjacent control area, the aircraft shall be held within the transferring centre's area until flight plan and control information can be forwarded and co-ordination can be effected with the adjacent centre.

4.2.3.2 In the case of an aircraft requesting a change in its current flight plan, or of a transferring centre proposing to change the current flight plan of an aircraft in the vicinity of the boundary in circumstances similar to that described, the revised clearance shall be withheld pending acceptance of the proposal by the adjacent centre.

4.2.4 When boundary estimate data are to be transmitted in the circumstances mentioned in 4.2.3, the time in respect of an aircraft not yet departed shall be based upon the estimated time of departure as determined by the ATC unit at the departure aerodrome. In respect of an aircraft in flight requiring an initial clearance, the time shall be based on the estimated elapsed time from the holding point to the boundary plus the time expected to be needed for co-ordination.

4.2.5 With regard to the information provided by the transferring centre in accordance with 4.2.1 and 4.2.3, the accepting centre shall notify the transferring centre either that it is able to accept the aircraft concerned under the conditions specified or it shall specify to the transferring centre which changes to the flight plan are required so that the aircraft can be accepted; however, where special arrangements exist between the ATC units concerned, this notification shall only be required if the aircraft cannot be accepted as offered by the transferring centre.

4.2.6 The primary responsibility for the control of air traffic remains with the area control centre in whose control area the aircraft is operating until the time the aircraft is estimated to cross the boundary of that control area, even when control of one or more aircraft is exercised under delegation by other air traffic control units (see Annex 11, 3.5.2). It is emphasized that the accepting centre which is in communication with an aircraft not yet having reached the incoming transfer of control point shall not alter the clearance of such aircraft without the prior approval of the transferring centre.

Rules of the Air and Air Traffic Services (PANS-RAC)

Note.— When so agreed between the area control centres concerned, the transfer of control point may be a point other than the control area boundary.

4.2.7 In order to effect the transfer of control of an aircraft, the transferring centre shall, except as provided in 4.2.8, and in Part VI, 7.5.2, notify the accepting centre that the aircraft is in position to be handed over to it, and that the responsibility for control should be assumed by the accepting centre, either forthwith or, if a specified transfer of control point has been established, at the time when the aircraft passes that point. If the SSR Mode and Code currently radiated by the aircraft are known, and the accepting centre is able to make use of these data, they should be included in such notification. If transfer of radar control is to be effected, such notification shall also include information regarding the position (and track and speed, if required) of the radar position of the aircraft. Such notification shall also include significant changes in the data transmitted in accordance with 4.2.1 which have not been previously forwarded.

4.2.8 Where special arrangements exist between two area control centres which are not equipped with radar and which do not employ automatic data-processing equipment, the notification in 4.2.7 need only be made in circumstances where it is appropriate to forward a revision to previously transmitted current flight plan and control data at the time when the aircraft is in a position to be handed over to the accepting centre.

4.2.9 Where non-radar separation minima are being applied, the transfer of air-ground communications of an aircraft from the transferring to the accepting centre shall be made five minutes before the time at which the aircraft is estimated to reach the common control area boundary, unless otherwise agreed between the two area control centres concerned.

4.2.10 In circumstances where radar or ADS separation minima are being applied at the time of transfer of control, the transfer of air-ground voice and/or data communications of an aircraft from the transferring to the accepting centre shall be made immediately after the accepting centre has agreed to assume control unless the provisions of Part VI, 7.3.2 are applied.

4.2.11 A notification from the transferring centre that the aircraft will be cleared or has already been cleared to establish radio and/or data communications with the accepting centre is required in those cases where this has been agreed between the two area control centres concerned.

4.2.12 The accepting centre shall notify the transferring centre that radio and/or data communication has been established with the aircraft being transferred and control of the aircraft has been assumed, unless otherwise specified by agreement between the area control centres concerned.

4.2.13 In cases where a portion of a control area is so situated that the time taken by aircraft to traverse it does not permit the application of control by the centre concerned, agreement should be reached to provide for direct transfer between the centres responsible for the adjacent control areas, provided that the intermediate centre is fully informed of such traffic; it may also require the other centres to comply with any necessary requests to obviate interference with its own traffic.

4.2.14 In the case where a flight ceases to be operated as a controlled flight, i.e. by leaving controlled airspace or by cancelling its IFR flight and proceeding on VFR in airspace where VFR flights are not controlled, the area control centre concerned shall ensure that appropriate information on the flight is forwarded to ATS unit(s) responsible for the provision of flight information and alerting services for the remaining portion of the flight, in order to ensure that such services will, in fact, be provided to the aircraft.

4.3 Co-ordination between a unit providing area control service and a unit providing approach control service

4.3.1 *Division of control*

4.3.1.1 A unit providing approach control service may issue air traffic control clearances to any aircraft released to it by an area control centre without reference to the area control centre, except that when an approach has been missed the area control centre shall be advised immediately and subsequent action co-ordinated between the area control centre and the unit providing approach control service.

4.3.1.2 Time of take-off shall be specified by the area control centre when it is necessary to:

- a) co-ordinate the departure with traffic not released to the unit providing approach control service; and
- b) provide en-route separation between departing aircraft following the same route.

4.3.1.2.1 If time of take-off is not specified, the unit providing approach control service shall determine the take-off time when necessary to co-ordinate the departure with traffic released to it.

4.3.1.3 A clearance expiry time shall be specified by the area control centre if a delayed departure would conflict with traffic not released to the unit providing approach control service. If, for traffic reasons of its own, a unit providing approach control service has to specify in addition its own clearance expiry time, this shall in no case be later than that specified by the area control centre.

4.3.1.4 When weather conditions require an approach sequence, the area control centre shall clear arriving aircraft to the holding point, including holding instructions and expected approach time in such clearance. If the approach sequence is such that succeeding arrivals would be required to hold at high levels, such arrivals should be cleared to other points until lower levels are vacated in the approach sequence.

4.3.1.5 After co-ordination with the unit providing approach control service, the area control centre may clear the first arriving aircraft for approach rather than to a holding point.

4.3.1.6 After co-ordination with the unit providing approach control service, the area control centre may clear arriving aircraft to visual holding points to hold until further advised by the unit providing approach control service.

4.3.1.7 Any additional procedures necessary for proper co-ordination with reference to individual aerodromes shall be contained in local written instructions approved by the appropriate ATS authority. Where an approach control office is established, an area control centre may, after co-ordination with such office, release aircraft directly to aerodrome control towers if the entire approach will be made under visual meteorological conditions.

4.3.2 *Exchange of movement and control data*

4.3.2.1 *From the unit providing approach control service to the area control centre.* The unit providing approach control service shall keep the area control centre promptly advised of pertinent data on controlled traffic such as:

- a) lowest vacant level at the holding point available for use by the area control centre;

- b) expected type of instrument approach procedure;
- c) average time interval between successive approaches as determined by the unit providing approach control service;
- d) revision of the expected approach time issued by the area control centre when the calculation of the expected approach time by the unit providing approach control service indicates a variation of five minutes or such other time as has been agreed between the two ATC units concerned;
- e) arrival times over the holding point when these vary by three minutes, or such other time as has been agreed between the two ATC units concerned, from those previously estimated;
- f) cancellations by aircraft of their IFR flights, if these will affect levels at the holding point or expected approach times of other aircraft;
- g) departure times of departing aircraft;
- h) all available information relating to overdue or unreported aircraft;
- i) missed approaches.

4.3.2.2 *From the area control centre to the unit providing approach control service.* The area control centre shall keep the unit providing approach control service promptly advised of pertinent data on controlled traffic such as:

- a) identification, type and point of departure of arriving aircraft;
- b) estimated time and proposed level of arriving aircraft over holding point or actual time if aircraft is released to the unit providing approach control service after arrival over the holding point;
- c) requested type of instrument approach procedure if different to that specified in 4.3.2.1 b);
- d) expected approach time issued;
- e) statement that aircraft has been cleared to contact the unit providing approach control service;
- f) statement that an aircraft has been released to the unit providing approach control service including, if necessary, the time and conditions of release;
- g) anticipated delay to departing traffic due to congestion.

Rules of the Air and Air Traffic Services (PANS-RAC)

4.3.2.2.1 Information on arriving aircraft shall be forwarded not less than fifteen minutes before estimated time of arrival and such information shall be revised as necessary.

4.4 Co-ordination between a unit providing approach control service and a unit providing aerodrome control service

4.4.1 *Division of control*

4.4.1.1 A unit providing approach control service shall retain control of arriving aircraft until such aircraft have been cleared to the aerodrome control tower and are in communication with the aerodrome control tower. Not more than one arrival shall be cleared to a unit providing aerodrome control service during IMC, except when prior arrangements have been made by the appropriate ATS authority.

4.4.1.2 After co-ordination with the aerodrome control tower, the unit providing approach control service may clear arriving aircraft to visual holding points to hold until further advised by the aerodrome control tower.

4.4.1.3 A unit providing approach control service may authorize an aerodrome control tower to release an aircraft for take-off subject to the discretion of the aerodrome control tower with respect to arriving aircraft.

4.4.1.4 Aerodrome control towers shall obtain approval from the unit providing approach control service prior to authorizing operation of special VFR flights.

4.4.2 *Exchange of movement and control data*

4.4.2.1 *From an aerodrome control tower to the unit providing approach control service.* An aerodrome control tower shall keep the unit providing approach control service promptly advised of pertinent data on relevant controlled traffic such as:

- a) arrival and departure times;
- b) statement that the first aircraft in an approach sequence is in communication with and is sighted by the aerodrome control tower, and that reasonable assurance exists that a landing can be accomplished;
- c) all available information relating to overdue or unreported aircraft;

- d) information concerning missed approaches;
- e) information concerning aircraft that constitute essential local traffic to aircraft under the control of the unit providing approach control service.

4.4.2.2 *From the unit providing approach control service to an aerodrome control tower.* The unit providing approach control service shall keep the aerodrome control tower promptly advised of pertinent data on controlled traffic such as:

- a) estimated time and proposed level of arriving aircraft over the aerodrome, at least fifteen minutes prior to estimated arrival;
- b) statement that an aircraft has been cleared to contact the aerodrome control tower and that control shall be assumed by that unit;
- c) anticipated delay to departing traffic due to congestion.

4.5 Co-ordination between control positions within the same unit

4.5.1 Appropriate flight plan and control information shall be exchanged between control positions within the same air traffic control unit, in respect of:

- a) all aircraft for which responsibility for control will be transferred from one control position to another;
- b) aircraft operating in such close proximity to the boundary between control sectors that control of traffic within an adjacent sector may be affected;
- c) all aircraft for which responsibility for control has been delegated by a procedural controller to a radar controller, as well as other aircraft affected.

5. Co-ordination between air traffic services units and aeronautical telecommunication stations

5.1 When so prescribed by the appropriate ATS authority, air traffic services units shall ensure that the aeronautical telecommunications stations serving the centres concerned are informed regarding transfers of communications contact by aircraft. Unless otherwise provided, information to be made available shall comprise the identification of the aircraft (including SELCAL code, when necessary), the route or destination (where necessary), and the expected or actual time of communications transfer.

PART IX. AIR TRAFFIC SERVICES MESSAGES

1. Categories of messages

1.1 The messages listed below are authorized for transmission via the aeronautical fixed service (including the aeronautical fixed telecommunication network (AFTN), direct-speech circuits or digital data interchange between air traffic services units, and direct teletypewriter and computer-computer circuits), or via the aeronautical mobile service, as applicable. They are classified in categories relating to their use by the air traffic services and providing an approximate indication of their importance.

Note.— The Priority Indicator in parentheses after each type of message is that specified in Annex 10 (Vol. II, Chapter 4) for application when the message is transmitted on the AFTN.

1.2 Emergency messages

This category comprises:

- a) distress messages and distress traffic, including alerting messages relating to a distress phase (SS);
- b) urgency messages, including alerting messages relating to an alert phase or to an uncertainty phase (SS);
- c) other messages concerning known or suspected emergencies which do not fall under a) or b) above, and radiocommunication failure messages (FF or higher as required).

Note.— When the messages in a) and b) and, if required, in c) above are filed with the public telecommunication service, the Priority Indicator SVH, assigned to telegrams relating to the safety of life, is to be used in accordance with Article 25 of the International Telecommunication Convention, Malaga, 1973.

1.3 Movement and control messages

This category comprises:

- a) filed flight plan messages and associated update messages (FF), including:
 - filed flight plan messages

- delay messages
- modification messages
- flight plan cancellation messages
- departure messages
- arrival messages;

b) co-ordination messages (FF), including:

- current flight plan messages
- estimate messages
- co-ordination messages
- acceptance messages
- logical acknowledgement messages;

c) supplementary messages (FF), including:

- request flight plan messages
- request supplementary flight plan messages
- supplementary flight plan messages;

d) control messages (FF), including:

- clearance messages
- transfer of control messages
- flow control messages
- position report and air-report messages.

1.4 Flight information messages

This category comprises:

- a) messages containing traffic information (FF);
- b) messages containing meteorological information (FF or GG);
- c) messages concerning the operation of aeronautical facilities (GG);
- d) messages containing essential aerodrome information (GG);
- e) messages concerning air traffic incident reports (FF).

1.5 When justified by the requirement for special handling, messages in the fixed service should be assigned the Priority Indicator DD in place of the normal Priority Indicator.

2. General provisions

Note.— The use in this Part of expressions such as “originated”, “transmitted”, “addressed” or “received” does not necessarily imply that reference is made to a teletypewriter or digital data interchange for a computer-to-computer message. Except where specifically indicated, the messages described in this Part may also be transmitted by voice, in which case the four terms above represent “initiated”, “spoken by”, “spoken to” and “listened to” respectively.

2.1 Origination and addressing of messages

2.1.1 General

Note.— Movement messages in this context comprise flight plan messages, departure messages, delay messages, arrival messages, cancellation messages and position report messages and modification messages relevant thereto.

2.1.1.1 Messages for air traffic services purposes shall be originated by the appropriate air traffic services units or by aircraft as specified in Section 3, except that, through special local arrangements, air traffic services units may delegate the responsibility for originating movement messages to the pilot, the operator, or his designated representative.

2.1.1.2 Origination of movement, control and flight information messages for purposes other than air traffic services (e.g. operational control) shall, except as provided for in Annex 11, 2.15, be the responsibility of the pilot, the operator, or a designated representative.

2.1.1.3 Flight plan messages, amendment messages related thereto and flight plan cancellation messages shall, except as provided in 2.1.1.4, be addressed only to those air traffic services units which are specified in the provisions of 4.2. Such messages shall be made available to other air traffic services units concerned, or to specified positions within such units and to any other addressees of the messages, in accordance with local arrangements.

2.1.1.4 When so requested by the operator concerned, emergency and movement messages which are to be transmitted simultaneously to air traffic services units concerned, shall also be addressed to:

- a) one addressee at the destination aerodrome or departure aerodrome, and

Rules of the Air and Air Traffic Services (PANS-RAC)

- b) not more than two operational control units concerned,

such addressees to be specified by the operator or his designated representative.

2.1.1.5 When so requested by the operator concerned, movement messages transmitted progressively between air traffic services units concerned and relating to aircraft for which operational control service is provided by that operator shall, so far as practicable, be made available immediately to the operator or his designated representative in accordance with agreed local procedures.

2.1.2 Use of the AFTN

2.1.2.1 Air traffic services messages to be transmitted via the AFTN shall contain:

- a) information in respect of the priority with which it is to be transmitted and the addressees to whom it is to be delivered, and an indication of the date and time at which it is filed with the aeronautical fixed station concerned and of the Originator Indicator (see 2.1.2.5);
- b) the air traffic services data, preceded if necessary by the supplementary address information described in 2.1.2.6.1, and prepared in accordance with Appendix 3. These data will be transmitted as the text of the AFTN message.

2.1.2.2 Priority indicator

2.1.2.2.1 This shall consist of the appropriate two-letter Priority Indicator for the message as shown in parentheses for the appropriate category of message in Section 1.

Note.— It is prescribed in Annex 10 (Vol. II, Chapter 4) that the order of priority for the transmission of messages in the AFTN shall be as follows:

| <i>Transmission Priority</i> | <i>Priority Indicator</i> | |
|------------------------------|---------------------------|----|
| 1 | SS | |
| 2 | DD | FF |
| 3 | GG | KK |

2.1.2.3 Address

2.1.2.3.1 This shall consist of a sequence of Addressee Indicators, one for each addressee to whom the message is to be delivered.

2.1.2.3.2 Each Addressee Indicator shall consist of an eight-letter sequence comprising, in the following order:

- a) the ICAO four-letter Location Indicator assigned to the place of destination;

Note.— A list of ICAO Location Indicators is contained in Doc 7910 — Location Indicators.

- b) i) the ICAO three-letter designator identifying the aeronautical authority, service or aircraft operating agency addressed, or
- ii) in cases where no designator has been assigned, one of the following:
- “YXY” in the case where the addressee is a military service/organization,
 - “ZZZ” in the case where the addressee is an aircraft in flight,
 - “YYY” in all other cases;

Note.— A list of ICAO three-letter designators is contained in Doc 8585 — Designators for Aircraft Operating Agencies, Aeronautical Authorities and Services.

- c) i) the letter X, or
- ii) the one-letter designator identifying the department or division of the organization addressed.

2.1.2.3.3 The following three-letter designators shall be used when addressing ATS messages to ATS units:

| | |
|---|-----|
| Centre in charge of a Flight Information Region or an Upper Flight Information Region (whether ACC or FIC): | |
| — if the message is relevant to an IFR flight | ZQZ |
| — if the message is relevant to a VFR flight | ZFZ |
| Aerodrome Control Tower | ZTZ |
| Air Traffic Services Reporting Office | ZPZ |

Other three-letter designators for ATS units shall not be used for that purpose.

2.1.2.4 Filing time

2.1.2.4.1 The filing time shall consist of a six-digit date-time group indicating the date and the time of filing the message for transmission with the aeronautical fixed station concerned.

2.1.2.5 Originator Indicator

2.1.2.5.1 The Originator Indicator shall consist of an eight-letter sequence, similar to an Addressee Indicator (see 2.1.2.3.2 above), identifying the place of origin and the organization originating the message.

2.1.2.6 Supplementary information on the address and the origin

2.1.2.6.1 The following supplementary information is required when, in the Indicators of the Address and/or Origin, the three-letter designators “YXY”, “ZZZ” or “YYY” (see 2.1.2.3.2 b) ii) above) are used:

- a) the name of the organization or the identity of the aircraft concerned is to appear at the beginning of the text;
- b) the order of such insertions is to be the same as the order of the Addressee Indicators and/or the Originator Indicator;
- c) where there more than one such insertion, the last should be followed by the word “STOP”;
- d) where there are one or more insertions in respect of Addressee Indicators plus an insertion in respect of the Originator Indicator, the word “FROM” is to appear before that relating to the Originator Indicator.

Note.— ATS messages received in teletypewriter page-copy form

- 1) ATS messages received via the AFTN will have been placed within a communications “envelope” (preceding and following character sequences which are necessary to ensure correct transmission via the AFTN). Even the text of the AFTN message may be received with words or groups preceding and following the ATS text.
- 2) The ATS message may then be located by the simple rule that it is preceded by an Open Bracket, e.g., ‘(’ and followed by a Close Bracket, e.g., ‘)’.
- 3) In some local cases, the teletypewriter machines in use will always print two specific symbols other than Open Bracket and Close Bracket on receipt of ATS messages constructed as prescribed in Appendix 3. Such local variants are easily learned and are of no consequence.

2.2 Preparation and transmission of messages

2.2.1 Air traffic services messages shall be prepared and transmitted with standard texts in a standard format and in accordance with standard data conventions, as and when prescribed in Appendix 3.

2.2.2 When messages are exchanged orally between the relevant air traffic services units, an oral acknowledgement shall constitute evidence of receipt of the message. No confirmation in written form shall therefore be required.

Note.— See Annex 11, Chapter 6, regarding the requirement for recording of direct-speech communications.

3. Methods of message exchange

3.1 The lead-time requirements of air traffic control and flow control procedures shall determine the method of message exchange to be used for the exchange of ATS data.

3.1.1 The method of message exchange shall also be dependent upon the availability of adequate communications channels, the function to be performed, the types of data to be exchanged and the processing facilities at the centres concerned.

3.2 Basic flight plan data necessary for flow control procedures shall be furnished at least 60 minutes in advance of the flight. Basic flight plan data shall be provided by either a filed flight plan or a repetitive flight plan submitted by mail in the form of a repetitive flight plan listing form or other media suitable for electronic data processing systems.

3.2.1 Flight plan data submitted in advance of flight shall be updated by time, level and route changes and other essential information as may be necessary.

3.3 Basic flight plan data necessary for air traffic control purposes shall be furnished to the first en-route control centre at least 30 minutes in advance of the flight, and to each successive centre at least 20 minutes before the aircraft enters that centre's area of jurisdiction, in order for it to prepare for the transfer of control.

3.4 The second en-route centre and each successive centre shall be provided with current data, including updated basic flight plan data, contained in a current flight plan message or in an estimate message supplementing already available updated basic flight plan data.

Rules of the Air and Air Traffic Services (PANS-RAC)

3.5 In areas where automated systems are utilized for the exchange of flight plan data and where these systems provide data for several area control centres, approach control units and/or aerodrome control towers, the appropriate messages shall not be addressed to each individual ATS unit, but only to these automated systems.

Note.— Further processing and distribution of the data to its associated ATS units is the internal task of the receiving system.

3.6 Filed flight plan data and associated update messages

3.6.1 Filed flight plan data and associated update messages shall be addressed simultaneously to the first en-route control centre, to all other ATS units along the route of flight which are unable to obtain or process current flight plan data, and to air traffic flow management units concerned.

3.7 Co-ordination and transfer data

3.7.1 Progression of a flight between successive control sectors and/or control centres shall be effected by a co-ordination and transfer process comprising the following stages:

- a) the announcement of the flight and the proposed conditions of transfer of control; and
- b) co-ordination of the conditions of transfer and acceptance followed by the assumption of control by the receiving unit.

3.7.2 The announcement of the flight shall be by a current flight plan message containing all relevant ATS data or by an estimate message containing the proposed conditions of transfer. An estimate message shall be used only when updated basic flight plan data is already available at the receiving ATS unit.

3.7.3 A receiving ATS unit to whom the proposed conditions of transfer are not acceptable shall decline to accept the aircraft as proposed and shall initiate further co-ordination by proposing alternative acceptable conditions.

3.7.4 The co-ordination process shall be considered to be completed as soon as the proposed conditions contained in the current flight plan message, or in the estimate message or in one or more counter-proposals, are accepted by an operational or logical procedure.

3.7.5 Unless an operational acknowledgement is received, a logical acknowledgement message shall be automatically transmitted by the receiving computer in order to ensure the integrity of the co-ordination process employing computer-to-computer links. This message shall be transmitted when the transfer data has been received and processed to the point that, in the event of a temporary failure by the receiving computer, the information will be brought to the attention of the appropriate air traffic controller.

3.7.6 The transfer of control shall be either explicit or, by agreement between the two units concerned, implicit, i.e. no communication need be exchanged between the transferring and accepting units.

3.7.7 When the transfer of control involves exchange of data, the proposal for transfer shall include radar information if appropriate. Since the proposal relates to previously accepted co-ordination data, further co-ordination shall normally not be required. However, acceptance shall be required.

3.7.8 If after receipt of radar information the accepting centre is unable to identify the aircraft immediately, additional communication shall ensue to obtain new radar information, if appropriate.

3.7.9 When control has been assumed of the transferred aircraft the accepting unit shall complete the transfer of control process by communicating assumption of control to the transferring unit, unless special arrangements have been made between the units concerned.

3.8 Supplementary data

3.8.1 When basic flight plan data or supplementary flight plan data are required, request messages shall be addressed to the ATS unit which is most likely to have access to the required data.

Note.— See 4.2.4.2.1 and 4.2.4.3.1 for ATS units to which request messages shall be addressed.

3.8.2 If the requested information is available, a filed or a supplementary flight plan message shall be transmitted.

4. Message types and their application

4.1 Emergency messages

4.1.1 The various circumstances surrounding each known or suspected emergency situation preclude the speci-

cation of standard message types to provide for emergency communications, except as described in 4.1.2 and 4.1.3 below.

4.1.2 Alerting (ALR) messages

4.1.2.1 When an air traffic services unit considers that an aircraft is in a state of emergency as defined in Annex 11, Chapter 5, an alerting message shall be transmitted to any air traffic services unit that may be concerned with the flight and to the associated rescue co-ordination centres, containing such of the information specified in Appendix 3, Section 1, as is available or can be obtained.

4.1.2.2 When so agreed between the air traffic services units concerned, a communication relating to an emergency phase and originated by a unit employing automatic data-processing equipment may take the form of a modification message (as in 4.2.2.4), supplemented by a verbal message giving the additional details prescribed for inclusion in an alerting message.

4.1.3 Radiocommunication failure (RCF) messages

Note.— Provisions governing the action to be taken in the event of radiocommunication failure are set forth in Annex 2, 3.6.5.2, and in Part III, Section 17 of this document.

4.1.3.1 When an air traffic services unit is aware that an aircraft in its area is experiencing radiocommunication failure, an RCF message shall be transmitted to all subsequent ATS units along the route of flight which have already received basic flight plan data (FPL or RPL) and to the aerodrome control tower at the destination aerodrome, if basic flight plan data has been previously sent.

4.1.3.2 If the next ATS unit has not yet received basic flight plan data because it would receive a current flight plan message in the co-ordination process, then an RCF message and a CPL message shall be transmitted to this ATS unit. In turn, this ATS unit shall transmit an RCF message and a CPL message to the next ATS unit. The above process shall be repeated progressively from centre to centre up to the first ATS unit along the remaining route of flight to which basic flight plan data has already been sent.

4.2 Movement and control messages

4.2.1 Messages concerning the intended or actual movement of aircraft shall be based on the latest information

furnished to air traffic services units by the pilot, the operator or his designated representative, or derived from ground-based radar.

4.2.2 Filed flight plan messages and associated update messages

4.2.2.1 Filed flight plan messages and associated update messages comprise:

- filed flight plan messages (4.2.2.2)
- delay messages (4.2.2.3)
- modification messages (4.2.2.4)
- flight plan cancellation messages (4.2.2.5)
- departure messages (4.2.2.6)
- arrival messages (4.2.2.7).

4.2.2.2 Filed flight plan (FPL) messages

Note.— Instructions for the transmission of an FPL message are contained in Appendix 2.

4.2.2.2.1 Unless repetitive flight plan procedures are being applied or current flight plan messages are being employed, filed flight plan messages shall be transmitted for all flights for which a flight plan has been submitted with the object of being provided with air traffic control service, flight information service or alerting service along part or the whole of the route of flight.

4.2.2.2.2 A filed flight plan message shall be originated and addressed as follows by the air traffic services unit serving the departure aerodrome or, when applicable, by the air traffic services unit receiving a flight plan from an aircraft in flight:

- a) an FPL message shall be sent to the area control centre or flight information centre serving the control area or flight information region within which the departure aerodrome is situated;
- b) unless basic flight plan data are already available as a result of arrangements made for repetitive flight plans, an FPL message shall be sent to all centres in charge of each flight information region or upper flight information region along the route, which are unable to process current data. In addition, an FPL message shall be sent to the aerodrome control tower at the destination aerodrome. If so required, an FPL message shall also be sent to flow management centres responsible for ATS units along the route;

Rules of the Air and Air Traffic Services (PANS-RAC)

- c) when a potential reclearance in flight request (RIF) is indicated in the flight plan, the FPL message shall be sent to the additional centres concerned and to the aerodrome control tower of the revised destination aerodrome;
- d) where it has been agreed to use CPL messages but where information is required for early planning of traffic flow, an FPL message shall be transmitted to the area control centres concerned;
- e) for a flight along routes where flight information service and alerting service only are provided, an FPL message shall be addressed to the centre in charge of each flight information region or upper flight information region along the route and to the aerodrome control tower at the destination aerodrome.

4.2.2.2.3 In the case of a flight through intermediate stops, where flight plans for each stage of the flight are filed at the first departure aerodrome, the following procedure shall be applied:

- a) the air traffic services reporting office at the first departure aerodrome shall:
 - 1) transmit an FPL message for the first stage of flight in accordance with 4.2.2.2.2;
 - 2) transmit a separate FPL message for each subsequent stage of flight, addressed to the air traffic services reporting office at the appropriate subsequent departure aerodrome;
- b) the air traffic services reporting office at each subsequent departure aerodrome shall take action on receipt of the FPL message as if the flight plan has been filed locally.

4.2.2.2.4 When so required by agreement between the appropriate ATS authorities to assist in the identification of flights and thereby eliminate or reduce the need for interceptions in the event of deviations from assigned track, FPL messages for flights along specified routes or portions of routes in close proximity to flight information region boundaries shall also be addressed to the centres in charge of each flight information region or upper flight information region adjacent to such routes or portions of routes.

4.2.2.2.5 FPL messages shall normally be transmitted immediately after the filing of the flight plan. However, if a flight plan is filed more than 24 hours in advance of the

estimated off-block time of the flight to which it refers, that flight plan shall be held in abeyance until at most 24 hours before the flight begins so as to avoid the need for the insertion of a date group into that flight plan. In addition, if a flight plan is filed early and the provisions of 4.2.2.2.2 b) or e) or 4.2.2.2.3 apply, transmission of the FPL message may be withheld until one hour before the estimated off-block time, provided that this will permit each air traffic services unit concerned to receive the information at least 30 minutes before the time at which the aircraft is estimated to enter its area of responsibility.

4.2.2.3 Delay (DLA) messages

4.2.2.3.1 A DLA message shall be transmitted when the departure of an aircraft, for which basic flight plan data (FPL or RPL) has been sent, is delayed by more than 30 minutes after the estimated off-block time contained in the basic flight plan data.

4.2.2.3.2 The DLA message shall be transmitted by the air traffic services unit serving the departure aerodrome to all recipients of basic flight plan data.

Note.— See 4.2.3.4 concerning notification of a delayed departure of an aircraft for which a CPL message has been transmitted.

4.2.2.4 Modification (CHG) messages

4.2.2.4.1 A CHG message shall be transmitted when any change is to be made to basic flight plan data contained in previously transmitted FPL or RPL data. The CHG message shall be sent to those recipients of basic flight plan data which are affected by the change.

Note.— See 4.2.3.4 concerning notification of a change to co-ordination data contained in a previously transmitted current flight plan or estimate message.

4.2.2.5 Flight plan cancellation (CNL) messages

4.2.2.5.1 A flight plan cancellation (CNL) message shall be transmitted when a flight, for which basic flight plan data has been previously distributed, has been cancelled. The ATS unit serving the departure aerodrome shall transmit the CNL message to ATS units which have received basic flight plan data.

4.2.2.6 Departure (DEP) messages

4.2.2.6.1 Unless otherwise prescribed on the basis of regional air navigation agreements, a DEP message shall be

transmitted immediately after the departure of an aircraft for which basic flight plan data has been previously distributed.

4.2.2.6.2 The DEP message shall be transmitted by the ATS unit serving the departure aerodrome to all recipients of basic flight plan data.

Note.— See 4.2.3.4 concerning notification of the departure of an aircraft for which a CPL message has been transmitted.

4.2.2.7 Arrival (ARR) messages

4.2.2.7.1 When an arrival report is received by the ATS unit serving the arrival aerodrome, this unit shall transmit an ARR message:

- a) for a landing at the destination aerodrome:
 - 1) to the area control centre or flight information centre in whose area the arrival aerodrome is located, if required by that unit; and
 - 2) to the air traffic services unit, at the departure aerodrome, which originated the flight plan message, if that message included a request for an ARR message;
- b) for a landing at an alternate or other aerodrome:
 - 1) to the area control centre or flight information centre in whose area the arrival aerodrome is located; and
 - 2) to the aerodrome control tower at the destination aerodrome; and
 - 3) to the air traffic services reporting office at the departure aerodrome; and
 - 4) to the area control centre or flight information centre in charge of each flight information region or upper flight information region through which the aircraft would have passed according to the flight plan, had it not diverted.

4.2.2.7.2 When a controlled flight which has experienced failure of two-way communication has landed, the aerodrome control tower at the arrival aerodrome shall transmit an ARR message:

- a) for a landing at the destination aerodrome:

- 1) to all air traffic services units concerned with the flight during the period of the communication failure; and
 - 2) to all other air traffic services units which may have been alerted;
- b) for a landing at an aerodrome other than the destination aerodrome:

to the ATS unit serving the destination aerodrome; this unit shall then transmit an ARR message to other ATS units concerned or alerted as in a) above.

4.2.3 Co-ordination messages

Note.— The provisions governing co-ordination are contained in Part VIII. Phraseology to be used in voice communication is contained in Part X.

4.2.3.1 Co-ordination messages comprise:

- current flight plan messages (4.2.3.2)
- estimate messages (4.2.3.3)
- co-ordination messages (4.2.3.4)
- acceptance messages (4.2.3.5)
- logical acknowledgement messages (4.2.3.6).

4.2.3.2 Current flight plan (CPL) messages

4.2.3.2.1 Unless basic flight plan data have already been distributed (FPL or RPL) which will be supplemented by co-ordination data in the estimate message, a CPL message shall be transmitted by each area control centre to the next area control centre and from the last area control centre to the aerodrome control tower at the destination aerodrome, for each controlled flight, and for each flight provided with air traffic advisory service along routes or portions of routes where it has been determined by the appropriate ATS authority that adequate point-to-point communications exist and that conditions are otherwise suitable for forwarding current flight plan information.

4.2.3.2.2 When an aircraft traverses a very limited portion of a control area where, by agreement between the appropriate ATS authorities concerned, co-ordination of air traffic through that portion of the control area has been delegated to and is effected directly by the two centres whose control areas are separated by that portion, CPLs shall be transmitted directly between such units.

Rules of the Air and Air Traffic Services (PANS-RAC)

4.2.3.2.3 A CPL message shall be transmitted in sufficient time to permit each air traffic services unit concerned to receive the information at least 20 minutes before the time at which the aircraft is estimated to pass the transfer of control point or boundary point at which it comes under the control of such unit, unless another period of time has been prescribed by the appropriate ATS authority. This procedure shall apply whether or not the ATS unit responsible for origination of the message has assumed control of, or established contact with, the aircraft by the time the transmission is to be effected.

4.2.3.2.4 When a CPL message is transmitted to a centre which is not using automatic data processing equipment, the period of time specified in 4.2.3.2.3 may be insufficient, in which case an increased lead-time shall be agreed.

4.2.3.2.5 A CPL message shall include only information concerning the flight from the point of entry into the next control area or advisory airspace to the destination aerodrome.

4.2.3.3 Estimate (EST) messages

4.2.3.3.1 When basic flight plan data for a flight has been provided, an EST message shall be transmitted by each area control centre or flight information centre to the next area control centre or flight information centre along the route of flight.

4.2.3.3.2 An EST message shall be transmitted in sufficient time to permit the air traffic services unit concerned to receive the information at least 20 minutes before the time at which the aircraft is estimated to pass the transfer of control point or boundary point at which it comes under the control of such unit, unless another period of time has been prescribed by the appropriate ATS authority. This procedure shall apply whether or not the area control centre or flight information centre responsible for origination of the message has assumed control of, or established contact with, the aircraft by the time the transmission is to be effected.

4.2.3.3.3 When an EST message is transmitted to a centre which is not using automatic data processing equipment, the period of time specified in 4.2.3.3.2 may be insufficient, in which case an increased lead-time shall be agreed.

4.2.3.4 Co-ordination (CDN) messages

4.2.3.4.1 A CDN message shall be transmitted during the co-ordination process by an accepting unit to the transfer-

ring unit when the former wishes to propose a change to co-ordination data as contained in a previously received CPL or EST message.

4.2.3.4.2 If the transferring unit wishes to propose a change to the data contained in a CDN message received from the accepting unit, a CDN message shall be transmitted to the accepting unit.

4.2.3.4.3 The process described above is repeated until the co-ordination process is completed by the transmission of an acceptance (ACP) message by one of the two units concerned. Normally, however, when a change is proposed to a CDN message, direct-speech circuits shall be used to resolve this issue.

4.2.3.4.4 After the co-ordination process has been completed, if one of the two ATS units concerned wishes to propose or notify any change in basic flight plan data or conditions of transfer, a CDN message shall be transmitted to the other unit. This requires that the co-ordination process must be repeated.

4.2.3.4.5 A repeated co-ordination process requires to be completed by the transmission of an ACP message. Normally, in a repeated co-ordination process, direct-speech circuits shall be used.

4.2.3.5 *Acceptance (ACP) message*

4.2.3.5.1 Unless special arrangements have been made between the air traffic control units concerned in accordance with Part VIII, 4.2.5, an ACP message shall be transmitted by an accepting unit to the transferring unit to indicate that data in a CPL or an EST message is accepted.

4.2.3.5.2 Either the accepting unit or the transferring unit shall transmit an ACP message to indicate that data received in a CDN message is accepted and that the co-ordination process is completed.

4.2.3.6 *Logical acknowledgement (LAM) messages*

4.2.3.6.1 An LAM message shall be used only between ATC computers.

4.2.3.6.2 An ATC computer shall transmit an LAM message in response to a CPL or EST or other appropriate message which is received and processed up to the point where the operational content will be received by the appropriate controller.

4.2.3.6.3 The transferring centre shall set an appropriate reaction time parameter when the CPL or EST message is transmitted. If the LAM message is not received within the parameter time, an operational warning shall be initiated and reversion to telephone and manual mode shall ensue.

4.2.4 *Supplementary messages*

4.2.4.1 Supplementary messages comprise:

- request flight plan messages (4.2.4.2)
- request supplementary flight plan messages (4.2.4.3)
- supplementary flight plan messages (4.2.4.4).

4.2.4.2 *Request flight plan (RQP) messages*

4.2.4.2.1 A request flight plan (RQP) message shall be transmitted when an ATS unit wishes to obtain flight plan data. This might occur upon receipt of a message concerning an aircraft for which no corresponding basic flight plan data had been previously received. The RQP message shall be transmitted to the transferring ATS unit which originated an EST message, or to the centre which originated an update message for which no corresponding basic flight plan data are available. If no message has been received at all, but an aircraft establishes RTF communications and requires air traffic services, the RQP message shall be transmitted to the previous ATS unit along the route of flight.

4.2.4.3 *Request supplementary flight plan (RQS) messages*

4.2.4.3.1 A request supplementary flight plan (RQS) message shall be transmitted when an air traffic services unit wishes to obtain supplementary flight plan data. The message shall be transmitted to the air traffic services reporting office at the departure aerodrome or in the case of a flight plan submitted during flight, to the air traffic services unit specified in the flight plan message.

4.2.4.4 *Supplementary flight plan (SPL) messages*

Note.— Instructions for the transmission of an SPL are contained in Appendix 2.

4.2.4.4.1 An SPL message shall be transmitted by the air traffic services reporting office at the departure aerodrome to air traffic services units requesting information additional to that already transmitted in a CPL or FPL message. When transmitted by the AFTN, the message shall be assigned the same priority indicator as that in the request message.

4.2.5 Control messages

4.2.5.1 Control messages comprise:

- clearance messages (4.2.5.2)
- transfer of control messages (4.2.5.3)
- flow control messages (4.2.5.4)
- position report and air-report messages (4.2.5.5).

4.2.5.2 Clearance messages

Note.— Provisions governing clearances are contained in Part II, Section 10, and Part III, Sections 10 to 13. The following paragraphs set forth the contents of clearance messages together with certain procedures relating to the transmission thereof. Specifications regarding the formats and data conventions to be used have not yet been developed by ICAO.

4.2.5.2.1 Clearances shall contain the following in the order listed:

- a) aircraft identification;
- b) clearance limit;
- c) route of flight;
- d) level(s) of flight for the entire route or part thereof and changes of levels if required;

Note.— If the clearance for the levels covers only part of the route, it is important for the air traffic control unit to specify a point to which the part of the clearance regarding levels applies whenever necessary to ensure compliance with 3.6.5.2.2 a) of Annex 2.

- e) any necessary instructions or information on other matters such as SSR transponder operation, approach or departure manoeuvres, communications and the time of expiry of the clearance.

Note.— The time of expiry of the clearance indicates the time after which the clearance will be automatically cancelled if the flight has not been started.

4.2.5.2.2 Instructions included in clearances relating to levels shall consist of:

- a) cruising level(s) or, for cruise climb, a range of levels, and, if necessary, the point to which the clearance is valid with regard to the level(s);

Note.— See 4.2.5.2.1 d) above and associated Note.

- b) levels at which specified significant points are to be crossed, when necessary;
- c) the place or time for starting climb or descent, when necessary;
- d) the rate of climb or descent, when necessary;
- e) detailed instructions concerning departure or approach levels, when necessary.

4.2.5.2.3 It is the responsibility of the aeronautical station or aircraft operator who has received the clearance to transmit it to the aircraft at the specified or expected delivery time, and to notify the air traffic control unit promptly if it is not delivered within a specified period of time.

4.2.5.2.4 Personnel receiving clearances for transmission to aircraft shall transmit such clearances in the exact phraseology in which they are received. In those cases where the personnel transmitting the clearances to the aircraft do not form part of the air traffic services, it is essential that appropriate arrangements be made to meet this requirement.

4.2.5.3 Transfer of control messages

Note.— The provisions governing transfer of control are contained in Annex 11, 3.6.2, and in Part VIII of this document. Phraseology to be used in voice communications is contained in Part X, 3.5, of this document. Format and data conventions for automated interchange of transfer of control messages have not yet been developed.

4.2.5.4 Flow control messages

Note 1.— Provisions governing the control of air traffic flow are set forth in Annex 11, 3.7.4 and in Part II, Section 11, of this document. Attention is drawn, however, to the guidance material contained in the Air Traffic Services Planning Manual (Doc 9426) regarding flow control.

Note 2.— Format and data conventions for automated interchange of flow control messages have not yet been developed.

4.2.5.5 Position report and air-report messages

Note.— Provisions governing position reporting are set forth in Annex 2, 3.6.3 and 5.3.3, and in Part II, Sections 14 and 15, of this document.

4.2.5.5.1 The format and data conventions to be used in position report and air-report messages are those specified on the model AIREP/AIREP SPECIAL form at Appendix 1, using:

- for position-report messages: Section 1;
- for air-report messages: Section 1 followed by Sections 2 and/or 3 as relevant.

4.2.5.5.2 Where special air-report messages transmitted by voice communications are subsequently forwarded by automatic data processing equipment which cannot accept the special air-report message type designator ARS, the use of a different message-type designator shall be permitted by regional air navigation agreement and should be reflected in the *Regional Supplementary Procedures* (Doc 7030) provided that:

- a) the data transmitted accord with that specified in the special air-report format; and
- b) measures are taken to ensure that special air-report messages are forwarded to the appropriate meteorological unit and to other aircraft likely to be affected.

4.3 Flight information messages

4.3.1 Messages containing traffic information

Note.— Provisions governing the issuance of traffic information are set forth in Annex 11, 4.2.2 b) and Notes 1 and 2 and in Part III, Section 14, and Part V, Section 7, of this document.

4.3.1.1 Messages containing traffic information to aircraft operating outside controlled airspace

4.3.1.1.1 Due to the factors influencing the nature of the flight information services, and particularly the question of provision of information on possible collision hazards to aircraft operating outside controlled airspace, it is not possible to specify standard texts for these messages.

4.3.1.1.2 Where such messages are transmitted they shall, however, contain sufficient data on the direction of flight and the estimated time, level and point at which the aircraft involved in the possible collision hazard will pass,

overtake or approach each other. This information shall be given in such a way that the pilot of each aircraft concerned is able to appreciate clearly the nature of the hazard.

4.3.1.2 Messages containing essential traffic information to IFR flights within controlled airspace

4.3.1.2.1 Whenever such messages are transmitted they shall contain the following text:

- a) identification of the aircraft to which the information is transmitted;
- b) the words TRAFFIC IS or ADDITIONAL TRAFFIC IS;
- c) direction of flight of aircraft concerned;
- d) type of aircraft concerned;
- e) cruising level of aircraft concerned and ETA for the significant point nearest to where the aircraft will cross levels.

4.3.1.3 Messages containing essential local traffic information

4.3.1.3.1 Whenever such messages are transmitted they shall contain the following text:

- a) identification of the aircraft to which the information is transmitted;
- b) the words TRAFFIC IS or ADDITIONAL TRAFFIC IS, if necessary;
- c) description of the essential local traffic in terms that will facilitate recognition of it by the pilot, e.g. type, speed category and/or colour of aircraft, type of vehicle, number of persons, etc.;
- d) position of the essential local traffic relative to the aircraft concerned, and direction of movement.

4.3.2 Messages containing meteorological information

Note.— Provisions governing the making and reporting of aircraft observations are contained in Annex 3. Provisions concerning the contents and transmission of air-reports are contained in Part II, Section 15, of this document, and the

special air-report of volcanic activity form used for reports of volcanic activity is shown in Appendix 1 to this document. The transmission by ATS units, to meteorological offices, of meteorological information received from aircraft in flight is governed by provisions in Part II, Section 16, of this document. Provisions governing the transmission by ATS units of meteorological information to aircraft are set forth in Annex 11, 4.2 and in this document (see Part II, 9.3 and 12.3; Part IV, 6 and 15; Part V, 7; and Part VII, 1.3). The written forms of SIGMET and AIRMET messages and other plain language meteorological messages are governed by the provisions of Annex 3.

4.3.2.1 Information to a pilot changing from IFR flight to VFR flight where it is likely that flight in VMC cannot be maintained shall be given in the following manner:

“INSTRUMENT METEOROLOGICAL CONDITIONS REPORTED (or forecast) IN THE VICINITY OF (location)”.

4.3.2.2 Meteorological information concerning the meteorological conditions at aerodromes, to be transmitted to aircraft by the ATS unit concerned, in accordance with Annex 11, Chapter 4 and this document, Part IV, Sections 6 and 15 and Part V, Section 7, shall be extracted by the ATS unit concerned from the following meteorological messages, provided by the appropriate meteorological office, supplemented for arriving and departing aircraft, as appropriate, by information from indicators relating to meteorological sensors (in particular, those related to the surface wind and runway visual range) located in the ATS units:

- a) meteorological reports disseminated locally at the aerodrome, intended for arriving and departing aircraft;
- b) meteorological reports disseminated beyond the aerodrome, exchanged in METAR and SPECI code forms, intended for aircraft en-route.

4.3.2.3 The meteorological information referred to in 4.3.2.2 shall be extracted, as appropriate, from meteorological reports providing information in accordance with the following:

4.3.2.3.1 *Mean surface wind direction and speed and significant variations therefrom*

4.3.2.3.1.1 In meteorological reports, the direction shall be given in degrees true and the speed in km/h (kt). All

Rules of the Air and Air Traffic Services (PANS-RAC)

directional and speed variations shall refer to the preceding 10-minute period. Directional variation shall be given when the total variation is 60 degrees or more; when the mean speed is above 6 km/h (3 kt) and the wind varies less than 180 degrees, it shall be expressed as the two extreme directions between which the wind has varied; otherwise, it shall be indicated as VRB, followed by the mean speed, with no indication of the mean wind direction. Speed variations (gusts) shall be reported only when the variation from the mean speed is 20 km/h (10 kt) or more.

Note.— Information on surface wind direction provided to ATS units by the associated meteorological office is referenced to degrees true North. Information on surface wind direction obtained from the ATS surface wind indicator and passed to pilots by ATS units is given in degrees magnetic.

4.3.2.3.1.2 In meteorological reports disseminated locally at the aerodrome:

- a) the averaging period for mean surface wind direction and speed shall be 2 minutes;
- b) speed variations shall be expressed as the maximum and minimum values attained;
- c) in reports to departing aircraft, light and variable surface winds of 6 km/h (3 kt) or less shall include a range of wind directions, whenever possible.

4.3.2.3.1.3 In meteorological reports disseminated beyond the aerodrome:

- a) the averaging period for mean surface wind direction and speed shall be 10 minutes;
- b) speed variations shall be expressed as the maximum value attained. Minimum wind speed shall not be included.

4.3.2.3.2 *Visibility, including significant directional variations*

4.3.2.3.2.1 When the visibility is less than 500 m, it shall be expressed in steps of 50 m; when it is 500 m or more but less than 5 000 m, in steps of 100 m; 5 000 m or more but less than 10 km, in kilometre steps; and when it is 10 km or more, only 10 km shall be given, except when the conditions for the use of CAVOK apply.

4.3.2.3.2.2 In meteorological reports disseminated locally at the aerodrome, the visibility shall be representative of:

- a) the take-off and climb out areas for departing aircraft;
- b) the approach and landing area for arriving aircraft.

4.3.2.3.2.3 In meteorological reports disseminated beyond the aerodrome, the visibility shall be representative of the aerodrome and its immediate vicinity. In case of significant directional variations in visibility:

- a) the lowest visibility shall be reported;
- b) additional values shall be given with indications of the direction of observation.

4.3.2.3.3 Runway visual range

4.3.2.3.3.1 Runway visual range values up to 800 m shall be given in increments of 25 to 60 m, in accordance with available observations, and values above 800 m shall be given in increments of 100 m. Runway visual range values which do not fit the reporting scale in use shall be rounded down to the nearest lower step in the reporting scale.

4.3.2.3.3.2 In meteorological reports disseminated locally at the aerodrome, the averaging period for RVR shall be 1 minute and:

- a) when the runway visual range is above the maximum value which can be determined by the system in use, it shall be reported as more than the specified distance, e.g. RVR RWY 14 ABV 1 200M where the figure 1 200 is the maximum value that can be determined by the system;

or

when the runway visual range is below the minimum value which can be measured with the system in use, it shall be reported as less than the specified distance, e.g. RVR RWY 10 BLW 150M.

- b) when the runway visual range is observed from one location along the runway about 300 m from the threshold, it shall be included without any indication of location, e.g. RVR RWY 20 600M;

or

when the runway visual range is observed from more than one location along the runway, the value for the touchdown zone shall be given first and shall be followed by the values representative of the mid-point and stop-end. The locations for which these values are representative shall be given in meteorological reports as TDZ, MID and END, e.g. RVR RWY 16 TDZ 600M MID 400M END 400M;

Note.— Where reports for three locations are given, the indication of these locations may be omitted, provided that the reports are passed in the order specified above, e.g. RVR RWY 16 600M 400M 400M.

- c) when there is more than one runway in use, the available runway visual range values for each runway shall be given and the runways to which the values refer shall be indicated, e.g. RVR RWY 26 800M RVR RWY 20 700M; if the runway visual range is available only for one runway, that runway shall be indicated, e.g. RVR RWY 20 600M.

4.3.2.3.3.3 In meteorological reports disseminated beyond the aerodrome, the averaging period for RVR shall be 10 minutes and:

- a) only the value representative of the touchdown zone shall be given, and no indication of location on the runway shall be included;
- b) when there is more than one runway available for landing, touchdown zone runway visual range values shall be included for all such runways, up to a maximum of four, and the runways to which the values refer shall be indicated, e.g. RVR RWY 26 500M RVR RWY 20 800M;
- c) when the runway visual range values during the 10-minute period immediately preceding the observation have shown a distinct tendency, such that the mean during the first 5 minutes varies by 100 m or more from the mean during the second 5 minutes of the period, this shall be indicated by the abbreviation “U” for an upward tendency and by the abbreviation “D” for the downward tendency, e.g. RVR RWY 12 300M/D;
- d) when the fluctuations of the runway visual range during the 10-minute period immediately preceding the observation have shown no distinct tendency, this shall be indicated by the abbreviation “N”;

- e) when the one-minute runway visual range values during the 10-minute period immediately preceding the observation vary from the mean value by more than 50 m or more than 20 per cent of the mean value, whichever is the greater, the one-minute mean minimum and the one-minute mean maximum values shall be included instead of the 10-minute mean value, e.g. RVR RWY 18 MNM700M MAX1100M.

4.3.2.3.4 *Present weather*

4.3.2.3.4.1 The types of the present weather phenomena shall be given in meteorological reports in terms of drizzle, rain, snow, snow grains, ice pellets, ice crystals (diamond dust), hail, small hail and/or snow pellets, fog, mist, sand, dust (widespread), haze, smoke, volcanic ash, dust/sand whirls (dust devils), squall, funnel cloud (tornado or waterspout), dust storm and sand storm.

4.3.2.3.4.2 The following characteristics of the present weather phenomena shall be given, as appropriate, in connection with the types listed in 4.3.2.3.4.1: thunderstorm, shower, freezing, blowing, low drifting, shallow, patches and partial.

4.3.2.3.4.3 The relevant intensity (light, moderate, heavy) or, as appropriate, the proximity to the aerodrome (vicinity) of the reported present weather phenomena shall be given.

4.3.2.3.5 *Amount and height of base of low cloud*

Cloud amount using FEW (1-2 oktas), SCT (3-4 oktas), BKN (5-7 oktas) or OVC (8 oktas), type (only if cumulonimbus (CB) or towering cumulus (TCU)) and height of base in metres (feet) shall be given in that order. If the base of the lowest cloud is diffuse or ragged or fluctuating rapidly, the minimum height of the cloud or cloud fragments shall be given together with an appropriate description of the characteristics thereof. If there are no clouds and no restriction on vertical visibility, and the abbreviation CAVOK is not appropriate, SKC shall be used. When the sky is obscured and information on vertical visibility is available, it shall be given as VER VIS, followed by the value of the vertical visibility.

4.3.2.3.6 *Air temperature and dew point*

Air temperature and dew point temperature shall be given rounded to the nearest whole degree Celsius, with observed values involving 0.5°C rounded to the next higher whole degree Celsius.

Rules of the Air and Air Traffic Services (PANS-RAC)

4.3.2.3.7 *Altimeter setting(s)*

The QNH altimeter setting shall be given and, either on a regular basis in accordance with local arrangements or if so requested by the pilot, the QFE altimeter setting. Altimeter settings shall be given in hectopascals and shall be rounded down to the nearest lower whole hectopascal.

4.3.2.3.8 *Other significant information*

4.3.2.3.8.1 This shall include any available information on meteorological conditions in the area of the aerodrome, and in the approach, missed approach or climb-out areas relating to the location of cumulonimbus or thunderstorm, moderate or severe turbulence, wind shear, hail, severe squall line, moderate or severe icing, freezing precipitation, severe mountain waves, sand storm, dust storm, blowing snow, tornado or waterspout, as well as any information on recent weather of operational significance (i.e. freezing precipitation; moderate or heavy precipitation; moderate or heavy blowing snow; duststorm or sandstorm; thunderstorm; tornado or waterspout; volcanic ash) observed during the period since the last issued routine report or last hour, whichever is shorter, but not at the time of observation.

4.3.2.3.8.2 In meteorological reports disseminated beyond the aerodrome, only information on wind shear and on recent weather of operational significance as given in 4.3.2.3.8.1 shall be included.

4.3.2.3.9 When the visibility is 10 km or more, there is no cloud below 1 500 m (5 000 ft), or below the highest minimum sector altitude, whichever is greater, and no cumulonimbus, and there is no weather of significance as given in 4.3.2.3.4.1 and 4.3.2.3.4.2, information on visibility, runway visual range, present weather and cloud amount, type and height shall be replaced by the term "CAVOK".

4.3.3 *Messages concerning the operation of aeronautical facilities*

Note.— General provisions concerning this subject are set forth in Annex 11, 4.2.

4.3.3.1 Messages concerning the operation of aeronautical facilities shall be transmitted to aircraft from whose flight plan it is apparent that the operation of the flight may be affected by the operating status of the operating facility concerned. They shall contain appropriate data on the service status of the facility in question, and, if the facility is out of operation, an indication when the normal operating status will be restored.

4.3.4 Messages containing information on aerodrome conditions

Note.— Provisions regarding the issuance of information on aerodrome conditions are contained in Part V, 8.

4.3.4.1 Whenever information is provided on aerodrome conditions, this shall be done in a clear and concise manner so as to facilitate appreciation by the pilot of the situation described. It shall be issued whenever deemed necessary by the controller on duty in the interest of safety, or when requested by an aircraft. If the information is provided on the initiative of the controller, it shall be transmitted to each aircraft concerned in sufficient time to enable the pilot to make proper use of the information.

4.3.4.2 Information that water is present on a runway shall be transmitted to each aircraft concerned, on the initiative of the controller, using the following terms:

DAMP — the surface shows a change of colour due to moisture.

WET — the surface is soaked but there is no standing water.

WATER PATCHES — patches of standing water are visible.

FLOODED — extensive standing water is visible.

4.3.5 Messages concerning air traffic incident reports

4.3.5.1 When an aircraft involved in an incident has a destination outside the area of responsibility of the ATS unit where the incident occurred, the ATS unit at the destination aerodrome should be notified and requested to obtain the pilot's report. The following information should be included in the message:

- a) type of incident (AIRPROX, procedure or facility);
- b) identification of the aircraft concerned;
- c) time and position at time of incident;
- d) brief details of incident.

PART X. PHRASEOLOGIES

1. Communications procedures

1.1 The communications procedures shall be in accordance with Volume II of Annex 10 — *Aeronautical Telecommunications*, and pilots, ATS personnel and other ground personnel shall be thoroughly familiar with the radiotelephony procedures contained therein.

2. General

2.1 Most phraseologies contained in Section 3 of this Part show the text of a complete message without call signs. They are not intended to be exhaustive, and when circumstances differ, pilots, ATS personnel and other ground personnel will be expected to use appropriate subsidiary phraseologies which should be as clear and concise as possible and designed to avoid possible confusion by those persons using a language other than one of their national languages.

2.2 The phraseologies are grouped according to types of air traffic service for convenience of reference. However, users shall be familiar with, and use as necessary, phraseologies from groups other than those referring specifically to the type of air traffic service being provided. All phraseologies shall be used in conjunction with call signs (aircraft, ground vehicle, ATC or other) as appropriate. In order that the phraseologies listed should be readily discernible in Section 3, call signs have been omitted. Provisions for the compilation of RTF messages, call signs and procedures are contained in Annex 10, Volume II, Chapter 5.

2.3 Section 3 includes phrases for use by pilots, ATS personnel and other ground personnel. Phraseologies for the movement of vehicles, other than tow-tractors, on the manoeuvring area are not listed separately as the phraseology associated with the movement of aircraft is applicable, with the exception of taxi instructions, in which case the word "PROCEED" shall be substituted for the word "TAXI" when communicating with vehicles.

2.4 Conditional phrases, such as "behind landing aircraft" or "after departing aircraft", shall not be used for movements affecting the active runway(s), except when the

aircraft or vehicles concerned are seen by the appropriate controller and pilot. In all cases a conditional clearance shall be given in the following order and consist of:

- i) identification;
- ii) the condition (specify); and
- iii) the clearance,

for example:

"SAS 941, BEHIND DC9 ON SHORT FINAL, LINE UP BEHIND".

Note.— This implies the need for the aircraft receiving the conditional clearance to identify the aircraft or vehicle causing the conditional clearance.

2.5 ATC route clearances shall always be read back unless otherwise authorized by the appropriate ATS authority, in which case they shall be acknowledged in a positive manner.

2.6 All clearances to enter, land on, take off on, cross and backtrack on the runway-in-use shall be read back.

2.7 Other clearances or instructions, including conditional clearances, shall be read back or acknowledged in a manner to clearly indicate that they have been understood and will be complied with.

2.8 Runway-in-use, altimeter settings, SSR Codes, level instructions, heading and speed instructions and, where so required by the appropriate ATS authority, transition levels, shall always be read back, e.g.:

Air traffic services: (aircraft call sign) "SQUAWK THREE FOUR TWO FIVE";
Aircraft reply: "THREE FOUR TWO FIVE, (aircraft call sign)".

Note.— If the level of an aircraft is reported in relation to standard pressure 1 013.2 hPa, the words "FLIGHT LEVEL" should precede the level figures. If the level of the aircraft is reported in relation to QNH/QFE, the figure should be followed by the word "METRES" or "FEET" as appropriate.

2.9 The phraseology in Section 3 does not include phrases and regular radiotelephony procedure words contained in Annex 10, Volume II.

phrases may be used. Words in square parentheses indicate optional additional words or information that may be necessary in specific instances.

2.10 Words in parentheses indicate that specific information, such as a level, a place or a time, etc., must be inserted to complete the phrase, or alternatively that optional

2.11 Examples of the application of the phraseologies contained in Parts VI and X may be found in the *Manual of Radiotelephony*.

3. Phraseologies

3.1 *General*

| <i>Circumstances</i> | <i>Phraseologies</i> |
|---|---|
| 3.1.1 Description of levels (subsequently referred to as “(level)”) | a) FLIGHT LEVEL (<i>number</i>); <i>or</i> b) (<i>number</i>) METRES; <i>or</i> c) (<i>number</i>) FEET. |
| 3.1.2 Level changes, reports and rates | a) CLIMB (<i>or</i> DESCEND); <i>followed as necessary by:</i> i) TO (<i>level</i>); ii) TO REACH (<i>level</i>) AT (<i>or</i> BY) (<i>time or significant point</i>); iii) REPORT LEAVING (<i>or</i> REACHING, <i>or</i> PASSING) (<i>level</i>); iv) REPORT PASSING ODD (<i>or</i> EVEN) LEVELS; v) AT (<i>number</i>) METRES PER SECOND (<i>or</i> FEET PER MINUTE) [MINIMUM (<i>or</i> MAXIMUM)]; vi) REPORT STARTING ACCELERATION (<i>or</i> DECELERATION). b) STEP CLIMB (<i>aircraft identification</i>) ABOVE (<i>or</i> BENEATH) YOU; c) REQUEST LEVEL CHANGE FROM (<i>name of unit</i>) AT (<i>time or significant point</i>); d) STOP CLIMB (<i>or</i> DESCENT) AT (<i>level</i>); e) CONTINUE CLIMB (<i>or</i> DESCENT) TO (<i>level</i>); |
| ... for SST aircraft only | |

| <i>Circumstances</i> | <i>Phraseologies</i> |
|--|---|
| | f) EXPEDITE CLIMB (or DESCENT) [UNTIL PASSING (<i>level</i>)]; |
| | g) WHEN READY CLIMB (or DESCEND) TO (<i>level</i>); |
| | h) EXPECT DESCENT AT (<i>time</i>); |
| | *i) REQUEST DESCENT AT (<i>time</i>); |
| ... to require action at a specific time or place | j) IMMEDIATELY; |
| | k) AFTER PASSING (<i>significant point</i>); |
| | l) AT (<i>time or significant point</i>); |
| ... to require action when convenient | m) WHEN READY (<i>instruction</i>); |
| ... to require an aircraft to climb or descend maintaining own separation and VMC | n) MAINTAIN OWN SEPARATION AND VMC [FROM (<i>level</i>)] [TO (<i>level</i>)]; |
| | o) MAINTAIN OWN SEPARATION AND VMC ABOVE (or BELOW, or TO) (<i>level</i>); |
| ... when there is doubt that an aircraft can comply with a clearance or instruction | p) IF NOT POSSIBLE (<i>alternative instructions</i>) AND ADVISE; |
| ... when a pilot is unable to comply with a clearance or instruction | *q) UNABLE TO COMPLY; |
| ... after modifying vertical speed to comply with an ACAS resolution advisory (Pilot and controller interchange) | *r) TCAS CLIMB (or DESCENT); |
| | s) (<i>acknowledgement</i>); |
| ... after ACAS “Clear of Conflict” is annunciated (Pilot and controller interchange) | *t) RETURNING TO (<i>assigned clearance</i>); |
| | u) (<i>acknowledgement</i>) (or <i>alternative instructions</i>); |
| ... after the response to an ACAS resolution advisory is completed (Pilot and controller interchange) | *v) TCAS CLIMB (or DESCENT), RETURNING TO (<i>assigned clearance</i>); |
| | w) (<i>acknowledgement</i>) (or <i>alternative instructions</i>); |

| Circumstances | Phraseologies |
|--|--|
| <p>... after returning to clearance after responding to an ACAS resolution advisory (Pilot and controller interchange)</p> <p>... when unable to comply with a clearance because of an ACAS resolution advisory (Pilot and controller interchange)</p> | <p>*x) TCAS CLIMB (or DESCENT), COMPLETED (assigned clearance) RESUMED;</p> <p>y) (acknowledgement) (or alternative instructions);</p> <p>*z) UNABLE TO COMPLY, TCAS RESOLUTION ADVISORY;</p> <p>aa) (acknowledgement).</p> <p>* Denotes pilot transmission.</p> |
| <p>3.1.3 Transfer of control and/or frequency change</p> | <p>a) CONTACT (unit call sign) (frequency);</p> <p>b) AT (or OVER) (time or place) CONTACT (unit call sign) (frequency);</p> <p>c) IF NO CONTACT (instructions);</p> <p>d) STAND BY (frequency) FOR (unit call sign);</p> <p>*e) REQUEST CHANGE TO (frequency);</p> <p>f) FREQUENCY CHANGE APPROVED;</p> <p>g) MONITOR (unit call sign) (frequency);</p> <p>*h) MONITORING (frequency);</p> <p>i) WHEN READY CONTACT (unit call sign) (frequency);</p> <p>j) REMAIN THIS FREQUENCY.</p> <p>* Denotes pilot transmission.</p> |
| <p><i>Note.— An aircraft may be requested to “STAND BY” on a frequency when it is intended that the ATS unit will initiate communications and to “MONITOR” a frequency when information is being broadcast thereon.</i></p> | |
| <p>3.1.4 Change of call sign</p> | <p>a) CHANGE YOUR CALL SIGN TO (new call sign) [UNTIL FURTHER ADVISED];</p> <p>b) REVERT TO FLIGHT PLAN CALL SIGN (call sign) [AT (significant point)].</p> |
| <p>... to instruct an aircraft to change its type of call sign</p> <p>... to advise an aircraft to revert to the call sign indicated in the flight plan</p> | |

Circumstances

Phraseologies

3.1.5 Traffic information

... to pass traffic information

... to acknowledge traffic information

- a) TRAFFIC (*information*);
- b) NO REPORTED TRAFFIC;
- *c) LOOKING OUT;
- *d) TRAFFIC IN SIGHT;
- *e) NEGATIVE CONTACT [*reasons*];
- f) [ADDITIONAL] TRAFFIC (*direction*) BOUND (*type of aircraft*) (*level*) ESTIMATED (*or* OVER) (*significant point*) AT (*time*);
- g) TRAFFIC IS (*classification*) UNMANNED FREE BALLOON(S) WAS [*or* ESTIMATED] OVER (*place*) AT (*time*) REPORTED (*level(s)*) [*or* LEVEL UNKNOWN] MOVING (*direction*) (*other pertinent information, if any*).

* Denotes pilot transmission.

3.1.6 Meteorological conditions

- a) WIND (*number*) DEGREES (*number*) (*units*);
 - b) WIND AT (*height/altitude/flight level*) (*number*) DEGREES (*number*) (*units*);
- Note.— Wind is always expressed by giving the mean direction and speed and any significant variations thereof.*

- c) VISIBILITY (*distance*) [*direction*];
- d) RUNWAY VISUAL RANGE (*or* RVR) [RUNWAY (*number*)] (*distance*);

... for multiple RVR observations

- e) RVR [RUNWAY (*number*)] (first position) (*distance*), (second position) (*distance*), (third position) (*distance*);

Note.— Multiple RVR observations are always representative of the touchdown zone, midpoint zone and the roll-out/stop end zone respectively.

... in the event that RVR information on any one position is not available this information will be included in the appropriate sequence

- f) RVR [RUNWAY (*number*)] (first position) (*distance*), (second position) MISSING, (third position) (*distance*);

- g) PRESENT WEATHER (*details*);

Circumstances

Phraseologies

| | | |
|-------|--|--|
| | | <p>h) CLOUD (<i>amount, [type] and height of base</i>) (or SKY CLEAR);</p> <p>i) CAVOK;</p> <p><i>Note.— CAVOK pronounced CAV-O-KAY.</i></p> <p>j) TEMPERATURE [MINUS] (<i>number</i>) (and/or DEW-POINT [MINUS] (<i>number</i>));</p> <p>k) QNH (or QFE) (<i>number</i>) [<i>units</i>];</p> <p>l) MODERATE (or SEVERE) ICING (or TURBULENCE) [IN CLOUD] (<i>area</i>);</p> <p>m) REPORT FLIGHT CONDITIONS.</p> |
| 3.1.7 | <p>Position reporting</p> <p>... to omit position reports until a specified position</p> | <p>a) NEXT REPORT AT (<i>significant point</i>);</p> <p>b) OMIT POSITION REPORTS [UNTIL (<i>specify</i>)];</p> <p>c) RESUME POSITION REPORTING.</p> |
| 3.1.8 | <p>Additional reports</p> <p>... to request a report at a specified place or distance</p> <p>... to request a report of present position</p> | <p>a) REPORT PASSING (<i>significant point</i>);</p> <p>b) REPORT (<i>distance</i>) FROM (<i>name of DME station</i>) DME;</p> <p>c) REPORT PASSING (<i>three digits</i>) RADIAL (<i>name of VOR</i>) VOR;</p> <p>d) REPORT DISTANCE FROM (<i>significant point</i>);</p> <p>e) REPORT DISTANCE FROM (<i>name of DME station</i>) DME.</p> |
| 3.1.9 | Aerodrome information | <p>a) RUNWAY (<i>number</i>) (<i>condition</i>);</p> <p>b) LANDING SURFACE (<i>condition</i>);</p> <p>c) CAUTION CONSTRUCTION WORK (<i>location</i>);</p> <p>d) CAUTION (<i>specify reasons</i>) RIGHT (or LEFT), (or BOTH SIDES) OF RUNWAY [<i>number</i>];</p> <p>e) CAUTION WORK IN PROGRESS (or OBSTRUCTION) (<i>position and any necessary advice</i>);</p> |

*Circumstances**Phraseologies*

3.1.10 Operational status of visual and non-visual aids

- f) RUNWAY REPORT AT (*observation time*) RUNWAY (*number*) (*type of precipitant*) UP TO (*depth of deposit*) MILLIMETRES. BRAKING ACTION GOOD (*or* MEDIUM TO GOOD, *or* MEDIUM, *or* MEDIUM TO POOR, *or* POOR *or* UNRELIABLE) [*and/or* BRAKING COEFFICIENT (*equipment and number*)];
- g) BRAKING ACTION REPORTED BY (*aircraft type*) AT (*time*) GOOD (*or* MEDIUM, *or* POOR);
- h) RUNWAY (*or* TAXIWAY) WET [*or* DAMP, WATER PATCHES, FLOODED (*depth*), *or* SNOW REMOVED (*length and width as applicable*), *or* TREATED, *or* COVERED WITH PATCHES OF DRY SNOW (*or* WET SNOW, *or* COMPACTED SNOW, *or* SLUSH, *or* FROZEN SLUSH, *or* ICE, *or* ICE UNDERNEATH, *or* ICE AND SNOW, *or* SNOWDRIFTS, *or* FROZEN RUTS AND RIDGES)].

- a) (*specify visual or non-visual aid*) RUNWAY (*number*) (*description of deficiency*);
- b) (*type*) LIGHTING (*unserviceability*);
- c) MLS/ILS CATEGORY (*category*) (*serviceability state*);
- d) TAXIWAY LIGHTING (*description of deficiency*);
- e) (*type of visual approach slope indicator*) RUNWAY (*number*) (*description of deficiency*);
- f) SECONDARY POWER SUPPLY NOT AVAILABLE.

*Circumstances**Phraseologies*3.2 Area control services
3.2.1 Issuance of a clearance

- a) (*name of unit*) CLEARS (*aircraft identification*);
- b) (*aircraft*) CLEARED TO;
- c) RECLEARED (*amended clearance details*);
- d) RECLEARED (*amended route portion*) TO (*significant point of original route*);
- e) ENTER CONTROL AREA (*or* ZONE) [VIA (*significant point*)] AT (*level*) [AT (*time*)];

Circumstances

Phraseologies

| | |
|--|---|
| | <p>f) LEAVE CONTROL AREA (or ZONE) AT (level) (or CLIMBING, or DESCENDING);</p> <p>g) JOIN (specify) AT (significant point) AT (level) [AT (time)].</p> |
| <p>3.2.2 Indication of route and clearance limit</p> | <p>a) FROM (place) TO (place);</p> <p>b) TO (place),</p> <p><i>followed as necessary by:</i></p> <p>i) DIRECT;</p> <p>ii) VIA (route and/or reporting points);</p> <p>iii) VIA FLIGHT PLANNED ROUTE;</p> <p><i>Note.— Conditions associated with the use of this phrase are in Part III, 12.2.</i></p> <p>iv) VIA (distance) ARC (direction) OF (name of DME station) DME;</p> <p>v) OUT OF CONTROL AREA (or ZONE) (distance) (direction) OF (place);</p> <p>c) (level or route) NOT AVAILABLE DUE (reason) ALTERNATIVE[S] IS/ARE (levels or routes) ADVISE.</p> |
| <p>3.2.3 Maintenance of specified levels</p> | <p>a) MAINTAIN (level) [TO (significant point)];</p> <p>b) MAINTAIN (level) UNTIL PASSING (significant point);</p> <p>c) MAINTAIN (level) UNTIL (time);</p> <p>d) MAINTAIN (level) UNTIL ADVISED BY (name of unit);</p> <p>e) MAINTAIN (level) UNTIL FURTHER ADVISED;</p> <p>f) MAINTAIN (level) WHILE IN CONTROLLED AIRSPACE;</p> <p>g) MAINTAIN AT LEAST (number) METRES (or FEET) ABOVE (or BELOW) (aircraft identification).</p> <p><i>Note.— The term “MAINTAIN” is not to be used in lieu of “DESCEND” or “CLIMB” when instructing an aircraft to change level.</i></p> |

| <i>Circumstances</i> | <i>Phraseologies</i> |
|--|--|
| 3.2.4 Specification of cruising levels | a) CROSS (<i>significant point</i>) AT (<i>or ABOVE, or BELOW</i>) (<i>level</i>); b) CROSS (<i>significant point</i>) AT (<i>time</i>) OR LATER (<i>or BEFORE</i>) AT (<i>level</i>) [MAINTAINING OWN SEPARATION AND VMC]; c) CRUISE CLIMB BETWEEN (<i>levels</i>) (<i>or ABOVE (level)</i>); d) CROSS (<i>distance</i>) (<i>name of DME station</i>) DME AT (<i>or ABOVE, or BELOW</i>) (<i>level</i>). |
| 3.2.5 Emergency descent | *a) EMERGENCY DESCENT (<i>intentions</i>); b) EMERGENCY DESCENT AT (<i>significant point or location</i>) ALL AIRCRAFT BELOW (<i>level</i>) WITHIN (<i>distance</i>) OF (<i>significant point or navigation aid</i>) LEAVE IMMEDIATELY (<i>followed as necessary by specific instructions as to direction, heading or track, etc.</i>). * Denotes pilot transmission. |
| 3.2.6 If clearance cannot be issued immediately upon request | EXPECT CLEARANCE AT (<i>time</i>). |
| 3.2.7 En-route absorption of terminal delay | AT (<i>time or position</i>) DESCEND TO (<i>level</i>) FOR EN-ROUTE DELAY OF (<i>number</i>) MINUTES. |
| 3.2.8 Separation instructions | a) CROSS (<i>significant point</i>) AT (<i>time</i>); b) ADVISE IF ABLE TO CROSS (<i>significant point</i>) AT (<i>time</i>); c) MAINTAIN MACH (<i>number</i>). |

3.3 *Approach control services*

| <i>Circumstances</i> | <i>Phraseologies</i> |
|------------------------------|--|
| 3.3.1 Departure instructions | a) AFTER DEPARTURE TURN RIGHT (<i>or LEFT</i>) HEADING (<i>three digits</i>); b) TURN RIGHT (<i>or LEFT</i>) HEADING (<i>three digits</i>); c) TRACK (<i>three digits</i>) DEGREES [MAGNETIC (<i>or TRUE</i>)] TO (<i>or FROM</i>) (<i>significant point</i>) UNTIL (<i>time, or REACHING (fix or significant point or level)</i>) [BEFORE SETTING HEADING]; |

Circumstances

Phraseologies

- d) SET HEADING AT (or BEFORE, or LATER THAN) (time);
- e) SET HEADING TO (or DIRECT) (significant point) AT (or BEFORE, or LATER THAN) (time);
- f) AFTER REACHING (or PASSING) (level or significant point) SET HEADING [DIRECT] (significant point);
- g) CLEARED VIA (designation).

Note.— Conditions associated with the use of this phrase are in Part III, 12.2.

3.3.2 Approach instructions

- a) CLEARED VIA (designation);
- b) CLEARED TO (clearance limit) VIA (designation);
- c) CLEARED VIA (details of route to be followed);
- d) CLEARED (type of approach) APPROACH [RUNWAY (number)];
- e) CLEARED APPROACH [RUNWAY (number)];
- f) COMMENCE APPROACH AT (time);
- *g) REQUEST STRAIGHT-IN APPROACH;
- h) CLEARED STRAIGHT-IN APPROACH [RUNWAY (number)];
- i) REPORT VISUAL;
- j) REPORT RUNWAY [LIGHTS] IN SIGHT;
- *k) REQUEST VISUAL APPROACH;
- l) CLEARED VISUAL APPROACH RUNWAY (number);
- m) REPORT (significant point); [OUTBOUND, or INBOUND];
- *n) REQUEST VMC DESCENT;
- o) MAINTAIN OWN SEPARATION;
- p) MAINTAIN VMC;

Circumstances

Phraseologies

| | |
|---|---|
| | <p>q) ARE YOU FAMILIAR WITH <i>(name)</i> APPROACH PROCEDURE;</p> <p>r) REPORT MLS CAPABILITY;</p> <p>*s) REQUEST <i>(type of approach)</i> APPROACH [RUNWAY <i>(number)</i>];</p> <p>*t) REQUEST <i>(MLS/RNAV plain language designator)</i>;</p> <p>u) CLEARED <i>(MLS/RNAV plain language designator)</i>.</p> <p>* Denotes pilot transmission.</p> |
| <p>3.3.3 Holding instructions</p> <p style="padding-left: 200px;">... visual</p> <p style="padding-left: 100px;">... published holding procedure over a facility or fix</p> <p style="padding-left: 100px;">... when pilot requires an oral description of holding procedure based on a facility (VOR or NDB)</p> | <p>a) HOLD VISUAL [OVER] <i>(position)</i>, (or BETWEEN <i>(two prominent landmarks)</i>);</p> <p>b) HOLD AT <i>(significant point, name of facility or fix)</i> (level) EXPECT APPROACH (or FURTHER CLEARANCE) AT <i>(time)</i>;</p> <p>*c) REQUEST HOLDING INSTRUCTIONS;</p> <p>d) HOLD AT <i>(name of facility)</i> (call sign and frequency, if necessary) (level) INBOUND TRACK <i>(three digits)</i> DEGREES RIGHT (or LEFT) HAND PATTERN OUTBOUND TIME <i>(number)</i> MINUTES <i>(additional instructions, if necessary)</i>;</p> <p>e) HOLD ON THE <i>(three digits)</i> RADIAL OF THE <i>(name)</i> VOR (call sign and frequency, if necessary) AT <i>(distance)</i> DME (or BETWEEN <i>(distance)</i> AND <i>(distance)</i> DME) (level) INBOUND TRACK <i>(three digits)</i> RIGHT (or LEFT) HAND PATTERN <i>(additional instructions, if necessary)</i>.</p> <p>* Denotes pilot transmission.</p> |
| <p>3.3.4 Expected approach time</p> | <p>a) NO DELAY EXPECTED;</p> <p>b) EXPECTED APPROACH TIME <i>(time)</i>;</p> <p>c) REVISED EXPECTED APPROACH TIME <i>(time)</i>;</p> <p>d) DELAY NOT DETERMINED <i>(reasons)</i>.</p> |

3.4 Phraseologies for use on and in the vicinity of the aerodrome

| Circumstances | Phraseologies |
|--|--|
| 3.4.1 Identification of aircraft | SHOW LANDING LIGHT. |
| 3.4.2 Acknowledgement by visual means | a) ACKNOWLEDGE BY MOVING AILERONS (<i>or</i> RUDDER); b) ACKNOWLEDGE BY ROCKING WINGS; c) ACKNOWLEDGE BY FLASHING LANDING LIGHTS. |
| 3.4.3 Starting procedures ... to request permission to start engines ... ATC replies | *a) [<i>aircraft location</i>] REQUEST START UP; *b) [<i>aircraft location</i>] REQUEST START UP, INFORMATION (<i>ATIS identification</i>); c) START UP APPROVED; d) START UP AT (<i>time</i>); e) EXPECT START UP AT (<i>time</i>); f) START UP AT OWN DISCRETION; g) EXPECT DEPARTURE (<i>time</i>) START UP AT OWN DISCRETION. * Denotes pilot transmission. |
| 3.4.4 Starting procedures (ground crew/cockpit) | a) [ARE YOU] READY TO START UP—; *b) STARTING NUMBER (<i>engine number(s)</i>). <p style="text-align: center;"><i>Note 1.— The ground crew should follow this exchange by either a reply on the intercom or a distinct visual signal to indicate that all is clear and that the start-up as indicated may proceed.</i></p> <p style="text-align: center;"><i>Note 2.— Unambiguous identification of the parties concerned is essential in any communications between ground crew and pilots.</i></p> * Denotes pilot transmission. |

Circumstances

Phraseologies

3.4.5 Push-back procedures

Note.— When local procedures so prescribe, authorization for pushback should be obtained from the control tower.

... aircraft/ATC

- *a) [*aircraft location*] REQUEST PUSHBACK;
- b) PUSHBACK APPROVED;
- c) STAND BY;
- d) PUSHBACK AT OWN DISCRETION;
- e) EXPECT (*number*) MINUTES DELAY DUE (*reason*);

... (ground crew/cockpit)

- f) ARE YOU READY FOR PUSHBACK—;
- *g) READY FOR PUSHBACK;
- h) CONFIRM BRAKES RELEASED;
- *i) BRAKES RELEASED;
- j) COMMENCING PUSHBACK;
- k) PUSHBACK COMPLETED;
- *l) STOP PUSHBACK;
- m) CONFIRM BRAKES SET;
- *n) BRAKES SET;
- *o) DISCONNECT;
- p) DISCONNECTING STAND BY FOR VISUAL AT YOUR LEFT (*or* RIGHT).

Note.— This exchange is followed by a visual signal to the pilot to indicate that disconnect is completed and all is clear for taxiing.

* Denotes pilot transmission.

| Circumstances | Phraseologies |
|---|--|
| 3.4.6 Towing procedures ... ATC response | †a) REQUEST TOW [<i>company name</i>] (<i>aircraft type</i>) FROM (<i>location</i>) TO (<i>location</i>); b) TOW APPROVED VIA (<i>specific routing to be followed</i>); c) HOLD POSITION; d) STAND BY. † Denotes transmission from aircraft/tow vehicle combination. |
| 3.4.7 To request time check and/or aerodrome data for departure ... when no ATIS broadcast is available | *a) REQUEST TIME CHECK; b) TIME (<i>minutes</i>); *c) REQUEST DEPARTURE INFORMATION; d) RUNWAY (<i>number</i>), WIND (<i>direction and speed</i>), QNH (<i>detail</i>), TEMPERATURE (<i>detail</i>), [VISIBILITY FOR TAKE-OFF (<i>detail</i>) (or RVR (<i>detail</i>))]. * Denotes pilot transmission. |
| 3.4.8 Taxi procedures ... for departure ... where detailed taxi instructions are required ... where aerodrome information is not available from an alternative source such as ATIS | *a) [<i>aircraft type</i>] [<i>wake turbulence category if "heavy"</i>] [<i>aircraft location</i>] REQUEST TAXI [<i>intentions</i>]; *b) [<i>aircraft type</i>] [<i>wake turbulence category if "heavy"</i>] [<i>aircraft location</i>] (<i>flight rules</i>) TO (<i>aerodrome of destination</i>) REQUEST TAXI [<i>intentions</i>]; c) TAXI TO HOLDING POINT [<i>number</i>] [RUNWAY (<i>number</i>)] [TIME (<i>minutes</i>)]; *d) [<i>aircraft type</i>] [<i>wake turbulence category if "heavy"</i>] REQUEST DETAILED TAXI INSTRUCTIONS; e) TAXI VIA (<i>specific routing to be followed</i>) TO HOLDING POINT [<i>number</i>] [RUNWAY (<i>number</i>)] [TIME (<i>minutes</i>)]; f) TAXI TO HOLDING POINT [<i>number</i>] (<i>followed by aerodrome information as applicable</i>) [TIME (<i>minutes</i>)]; g) TAKE (<i>or TURN</i>) FIRST (<i>or SECOND</i>) LEFT (<i>or RIGHT</i>); |

| <i>Circumstances</i> | <i>Phraseologies</i> |
|-------------------------------|--|
| | h) TAXI VIA (<i>identification of taxiway</i>); |
| | i) TAXI VIA RUNWAY (<i>number</i>); |
| | j) TAXI TO TERMINAL (<i>or other location, e.g. GENERAL AVIATION AREA</i>) [STAND (<i>number</i>)]; |
| ... for helicopter operations | *k) REQUEST AIR-TAXIING FROM (<i>or VIA</i>) TO (<i>location or routing as appropriate</i>); |
| | l) AIR-TAXI TO (<i>or VIA</i>) (<i>location or routing as appropriate</i>) [CAUTION (<i>dust, blowing snow, loose debris, taxiing light aircraft, personnel, etc.</i>)]; |
| | m) AIR TAXI VIA (<i>direct, as requested, or specified route</i>) TO (<i>location, heliport, operating or movement area, active or inactive runway</i>). AVOID (<i>aircraft or vehicles or personnel</i>); |
| ... after landing | *n) REQUEST BACKTRACK; |
| | o) BACKTRACK APPROVED; |
| | p) BACKTRACK RUNWAY (<i>number</i>); |
| ... general | *q) [<i>aircraft location</i>] REQUEST TAXI TO (<i>destination on aerodrome</i>); |
| | r) TAXI STRAIGHT AHEAD; |
| | s) TAXI WITH CAUTION; |
| | t) GIVE WAY TO (<i>description and position of other aircraft</i>); |
| | *u) GIVING WAY TO (<i>traffic</i>); |
| | *v) TRAFFIC (<i>or type of aircraft</i>) IN SIGHT; |
| | w) TAXI INTO HOLDING BAY; |
| | x) FOLLOW (<i>description of other aircraft or vehicle</i>); |
| | y) VACATE RUNWAY; |
| | *z) RUNWAY VACATED; |

Circumstances

Phraseologies

| | |
|---|--|
| | <p>aa) EXPEDITE TAXI [<i>reason</i>];</p> <p>*bb) EXPEDITING;</p> <p>cc) [CAUTION] TAXI SLOWER [<i>reason</i>];</p> <p>*dd) SLOWING DOWN.</p> <p>* Denotes pilot transmission.</p> |
| <p>3.4.9 Holding</p> <p>... to hold not closer to a runway than specified in Part V, 10.3.</p> | <p>‡a) HOLD (<i>direction</i>) OF (<i>position, runway number, etc.</i>);</p> <p>‡b) HOLD POSITION;</p> <p>‡c) HOLD (<i>distance</i>) FROM (<i>position</i>);</p> <p>‡d) HOLD SHORT OF (<i>position</i>);</p> <p>*e) HOLDING;</p> <p>*f) HOLDING SHORT.</p> <p>‡ Requires specific acknowledgement from the pilot. * Denotes pilot transmission. The procedure words ROGER and WILCO are insufficient acknowledgement of the instructions HOLD, HOLD POSITION and HOLD SHORT OF (<i>position</i>). In each case the acknowledgement shall be by the phraseology HOLDING or HOLDING SHORT, as appropriate.</p> |
| <p>3.4.10 To cross a runway</p> <p><i>Note 1.— Unless otherwise specified by ATC, a taxi instruction which contains a taxi limit beyond a runway includes permission to cross that runway.</i></p> <p><i>Note 2.— The pilot shall, when requested, report “RUNWAY VACATED” when the aircraft is well clear of the runway.</i></p> | <p>*a) REQUEST CROSS RUNWAY (<i>number</i>);</p> <p><i>Note.— If the control tower is unable to see the crossing aircraft (e.g. night, low visibility, etc.), the instruction should always be accompanied by a request to report when the aircraft has vacated and is clear of the runway.</i></p> <p>b) CROSS RUNWAY (<i>number</i>) [REPORT VACATED];</p> <p>c) EXPEDITE CROSSING RUNWAY (<i>number</i>) TRAFFIC (<i>aircraft type</i>) (<i>distance</i>) KILOMETRES (or MILES) FINAL;</p> <p>*d) RUNWAY VACATED.</p> <p>* Denotes pilot transmission.</p> |

Circumstances

Phraseologies

3.4.11 Preparation for take-off

- ... if unable to issue take-off clearance
- ... clearance to enter runway and await take-off clearance
- ... conditional clearances
- ... acknowledgement of a conditional clearance
- ... confirmation or otherwise of the readback of conditional clearance

- a) UNABLE TO ISSUE (*designator*) DEPARTURE (*reasons*);
- b) REPORT WHEN READY [FOR DEPARTURE];
- c) ARE YOU READY [FOR DEPARTURE]?;
- d) ARE YOU READY FOR IMMEDIATE DEPARTURE?;

*e) READY;

f) WAIT [*reason*];

g) LINE UP;

Note.— May be followed by phraseology f).

†h) LINE UP RUNWAY (*number*);

i) LINE UP. BE READY FOR IMMEDIATE DEPARTURE;

‡j) (*condition*) LINE UP;

*k) (*condition*) LINING UP;

l) [THAT IS] CORRECT (*or I SAY AGAIN ... (as appropriate)*).

* Denotes pilot transmission.

† When there is the possibility of confusion during multiple runway operations.

‡ Provisions concerning the use of conditional clearances are contained in 2.4.

3.4.12 Take-off clearance

- ... when there is a possibility of confusion
- ... when take-off clearance has not been complied with
- ... to cancel a take-off clearance

a) CLEARED FOR TAKE-OFF [REPORT AIRBORNE];

b) CLEARED FOR TAKE-OFF RUNWAY (*number*);

c) TAKE OFF IMMEDIATELY OR VACATE RUNWAY;

d) TAKE OFF IMMEDIATELY OR HOLD SHORT OF RUNWAY;

e) HOLD POSITION, CANCEL I SAY AGAIN CANCEL TAKE-OFF (*reasons*);

*f) HOLDING;

| Circumstances | Phraseologies |
|---|--|
| ... to stop a take-off in emergency conditions | g) STOP IMMEDIATELY (<i>repeat aircraft call sign</i>) STOP IMMEDIATELY; |
| ... for helicopter operations from other than the manoeuvring area | *h) STOPPING; i) CLEARED FOR TAKE-OFF FROM (<i>present position, taxiway, final approach and take-off area, runway and number</i>); *j) REQUEST DEPARTURE INSTRUCTIONS; k) AFTER DEPARTURE TURN RIGHT (<i>or LEFT, or CLIMB</i>) (<i>instructions as appropriate</i>). |
| 3.4.13 After take-off | * Denotes pilot transmission. HOLDING and STOPPING are the procedural responses to e) and g) respectively. |
| ... heading to be followed ... when a specific track is to be followed | *a) REQUEST RIGHT (<i>or LEFT</i>) TURN [WHEN AIRBORNE]; b) RIGHT (<i>or LEFT</i>) TURN APPROVED; c) WILL ADVISE LATER FOR RIGHT (<i>or LEFT</i>) TURN; d) AIRBORNE (<i>time</i>); e) AFTER PASSING (<i>level</i>) (<i>instructions</i>); f) CONTINUE ON (<i>magnetic direction of runway</i>) (<i>instructions</i>); g) TRACK (<i>magnetic direction of runway</i>) (<i>instructions</i>); h) CLIMB STRAIGHT AHEAD (<i>instructions</i>). |
| 3.4.14 Entering an aerodrome traffic circuit | * Denotes pilot transmission. *a) [<i>aircraft type</i>] (<i>position</i>) (<i>level</i>) FOR LANDING; b) JOIN (<i>position in circuit</i>) (<i>runway number</i>) [SURFACE] WIND (<i>direction and speed</i>) [TEMPERATURE (<i>degrees Celsius</i>)] QNH (<i>or QFE</i>) (<i>detail</i>) [HECTOPASCALS] [TRAFFIC (<i>detail</i>)]; c) MAKE STRAIGHT-IN APPROACH, RUNWAY (<i>number</i>) [SURFACE] WIND (<i>direction and speed</i>) [TEMPERATURE (<i>degrees Celsius</i>)] QNH (<i>or QFE</i>) (<i>detail</i>) [HECTOPASCALS] [TRAFFIC (<i>detail</i>)]; |

| <i>Circumstances</i> | <i>Phraseologies</i> |
|---|---|
| ... when right hand traffic circuit in use | d) JOIN RIGHT HAND (<i>position in circuit</i>) (<i>runway number</i>) [SURFACE] WIND (<i>direction and speed</i>) [TEMPERATURE (<i>degrees Celsius</i>)] QNH (or QFE) (<i>detail</i>) [HECTOPASCALS] [TRAFFIC (<i>detail</i>)]; |
| ... when ATIS information is available | *e) (<i>aircraft type</i>) (<i>position</i>) (<i>level</i>) INFORMATION (ATIS <i>identification</i>) FOR LANDING; f) JOIN (<i>position in circuit</i>) [RUNWAY (<i>number</i>)] QNH (or QFE) (<i>detail</i>) [HECTOPASCALS] [TRAFFIC (<i>detail</i>)]. * Denotes pilot transmission. |
| 3.4.15 In the circuit | *a) (<i>position in circuit, e.g.</i> DOWNWIND/FINAL); b) NUMBER ... FOLLOW (<i>aircraft type and position</i>) [<i>additional instructions if required</i>]. * Denotes pilot transmission. |
| 3.4.16 Approach instructions | a) MAKE SHORT APPROACH; b) MAKE LONG APPROACH (or EXTEND DOWNWIND); c) REPORT BASE (or FINAL, or LONG FINAL); d) CONTINUE APPROACH. |
| <i>Note.— The report “LONG FINAL” is made when aircraft turn on to final approach at a distance greater than 7 km (4 NM) from touchdown or when an aircraft on a straight-in approach is 15 km (8 NM) from touchdown. In both cases a report “FINAL” is required at 7 km (4 NM) from touchdown.</i> | |
| 3.4.17 Landing | a) CLEARED TO LAND; b) CLEARED TO LAND RUNWAY (<i>number</i>); c) CLEARED TOUCH AND GO; d) MAKE FULL STOP; *e) REQUEST LOW APPROACH (<i>reasons</i>); f) CLEARED LOW APPROACH [RUNWAY (<i>number</i>)] [(<i>altitude restriction if required</i>) (<i>go around instructions</i>)]; *g) REQUEST LOW PASS (<i>reasons</i>); h) CLEARED LOW PASS [<i>as in f</i>]; |
| ... multiple runway operations | |
| ... special operations | |
| ... to make an approach along, or parallel to a runway, descending to an agreed minimum level | |
| ... to fly past the control tower or other observation point for the purpose of visual inspection by persons on the ground | |

| Circumstances | Phraseologies |
|--|---|
| ... for helicopter operations | <p>*i) REQUEST STRAIGHT-IN (or CIRCLING APPROACH, LEFT (or RIGHT) TURN TO (location));</p> <p>j) MAKE STRAIGHT-IN (or CIRCLING APPROACH, LEFT (or RIGHT) TURN TO (location, runway, taxiway, final approach and take-off area)) [ARRIVAL (or ARRIVAL ROUTE) (number, name, or code)]. [HOLD SHORT OF (active runway, extended runway centre line, other)]. [REMAIN (direction or distance) FROM (runway, runway centre line, other helicopter or aircraft)]. [CAUTION (power lines, unlighted obstructions, wake turbulence, etc.)]. CLEARED TO LAND.</p> |
| 3.4.18 Delaying aircraft | <p>* Denotes pilot transmission.</p> <p>a) CIRCLE THE AERODROME;</p> <p>b) ORBIT (RIGHT, or LEFT) [FROM PRESENT POSITION];</p> <p>c) MAKE ANOTHER CIRCUIT.</p> |
| 3.4.19 Missed approach | <p>a) GO AROUND;</p> <p>*b) GOING AROUND.</p> <p>* Denotes pilot transmission.</p> |
| 3.4.20 Information to aircraft | <p>a) LANDING GEAR APPEARS DOWN;</p> <p>b) RIGHT (or LEFT, or NOSE) WHEEL APPEARS UP (or DOWN);</p> <p>c) WHEELS APPEAR UP;</p> <p>d) RIGHT (or LEFT, or NOSE) WHEEL DOES NOT APPEAR UP (or DOWN);</p> <p>e) CAUTION WAKE TURBULENCE;</p> <p>f) CAUTION JET BLAST;</p> <p>g) CAUTION SLIPSTREAM.</p> |
| ... wake turbulence | |
| ... jet blast on apron or taxiway | |
| ... propeller-driven aircraft slipstream | |
| 3.4.21 After landing | <p>a) CONTACT GROUND (frequency);</p> <p>b) WHEN VACATED CONTACT GROUND (frequency);</p> <p>c) EXPEDITE VACATING;</p> |

*Circumstances**Phraseologies*

- ... for helicopter operations
- d) YOUR STAND (or GATE) (*designation*);
 - e) TAKE (or TURN) FIRST (or SECOND, or CONVENIENT) LEFT (or RIGHT) AND CONTACT GROUND (*frequency*);
 - f) AIR-TAXI TO HELICOPTER STAND (or) HELICOPTER PARKING POSITION (*area*);
 - g) AIR-TAXI TO (or VIA) (*location or routing as appropriate*) [CAUTION (*dust, blowing snow, loose debris, taxiing light aircraft, personnel, etc.*)];
 - h) AIR TAXI VIA (*direct, as requested, or specified route*) TO (*location, heliport, operating or movement area, active or inactive runway*). AVOID (*aircraft or vehicles or personnel*).

3.5 *Co-ordination between ATS units**Circumstances**Phraseologies*

3.5.1 Estimates and revisions

- ... transmitting station
- ... receiving station reply
(if flight plan details
are available)
- ... transmitting station reply

- a) ESTIMATE [*direction of flight*] (*aircraft call sign*) [SQUAWKING (*SSR Code*)] (*type*) ESTIMATING (*significant point*) (*time*) (*level*) (or DESCENDING FROM (*level*) TO (*level*)) [SPEED (*filed TAS*)] (*route*) [REMARKS];
- b) ESTIMATE (*significant point*) ON (*aircraft call sign*);

(*aircraft type*) (*destination*);

[SQUAWKING (*SSR Code*)] [ESTIMATING] (*significant point*) (*time*) AT (*level*);

Note.— In the event that flight plan details are not available the receiving station shall reply to b) NO DETAILS and transmitting station shall pass full estimate as in a).
- c) ESTIMATE UNMANNED FREE BALLOON(S) (*identification and classification*) ESTIMATED OVER (*place*) AT (*time*) REPORTED FLIGHT LEVEL(S) (*figure or figures*) [or FLIGHT LEVEL UNKNOWN] MOVING (*direction*) ESTIMATED GROUND SPEED (*figure*) (*other pertinent information, if any*);
- d) REVISION (*aircraft call sign*) (*details as necessary*).

Circumstances

Phraseologies

| | | |
|-------|-------------------------|--|
| 3.5.2 | Transfer of control | <p>a) REQUEST RELEASE OF (<i>aircraft call sign</i>);</p> <p>b) (<i>aircraft call sign</i>) RELEASED [AT (<i>time</i>)] [<i>conditions/restrictions</i>];</p> <p>c) IS (<i>aircraft call sign</i>) RELEASED [FOR CLIMB (<i>or</i> DESCENT)]—;</p> <p>d) (<i>aircraft call sign</i>) NOT RELEASED [UNTIL (<i>time or significant point</i>)];</p> <p>e) UNABLE RELEASE (<i>aircraft call sign</i>) [TRAFFIC IS (<i>details</i>)].</p> |
| 3.5.3 | Change of clearance | <p>a) MAY WE CHANGE CLEARANCE OF (<i>aircraft call sign</i>) TO (<i>details of alteration proposed</i>)—;</p> <p>b) AGREED TO (<i>alteration of clearance</i>) OF (<i>aircraft call sign</i>);</p> <p>c) UNABLE TO APPROVE CHANGE TO CLEARANCE OF (<i>aircraft call sign</i>);</p> <p>d) UNABLE TO APPROVE (<i>desired route, level, etc.</i>) [OF (<i>aircraft call sign</i>)] [DUE (<i>reason</i>)] (<i>alternative clearance proposed</i>).</p> |
| 3.5.4 | Approval request | <p>a) APPROVAL REQUEST (<i>aircraft call sign</i>) ESTIMATED DEPARTURE FROM (<i>significant point</i>) AT (<i>time</i>);</p> <p>b) (<i>aircraft call sign</i>) REQUEST APPROVED [(<i>restriction if any</i>)];</p> <p>c) (<i>aircraft call sign</i>) UNABLE APPROVE (<i>alternative instructions</i>).</p> |
| 3.5.5 | Inbound release | <p>a) INBOUND RELEASE (<i>aircraft call sign</i>) [SQUAWKING (<i>SSR Code</i>)] (<i>type</i>) FROM (<i>departure point</i>) RELEASED AT (<i>significant point, or time, or level</i>) CLEARED TO AND ESTIMATING (<i>clearance limit</i>) (<i>time</i>) AT (<i>level</i>) [EXPECTED APPROACH TIME <i>or</i> NO DELAY EXPECTED] CONTACT AT (<i>time</i>).</p> |
| 3.5.6 | Radar handover | <p>a) RADAR HANDOVER (<i>aircraft call sign</i>) [SQUAWKING (<i>SSR Code</i>)] POSITION (<i>aircraft position or significant point</i>) (<i>level</i>).</p> |
| 3.5.7 | Expedition of clearance | <p>a) EXPEDITE CLEARANCE (<i>aircraft call sign</i>) EXPECTED DEPARTURE FROM (<i>place</i>) AT (<i>time</i>);</p> <p>b) EXPEDITE CLEARANCE (<i>aircraft call sign</i>) [ESTIMATED] OVER (<i>place</i>) AT (<i>time</i>) REQUESTS (<i>level or route, etc.</i>).</p> |

4. Radar phraseologies

Note.— The following comprise phraseologies specifically applicable when radar is used in the provision of air traffic services. The phraseologies detailed in the sections above for use in the provision of air traffic services are also applicable, as appropriate, when radar is used.

4.1 *General radar phraseologies*

| <i>Circumstances</i> | <i>Phraseologies</i> |
|----------------------------------|---|
| 4.1.1 Identification of aircraft | <ul style="list-style-type: none"> a) REPORT HEADING [AND FLIGHT LEVEL (<i>or</i> ALTITUDE)]; b) FOR IDENTIFICATION TURN LEFT (<i>or</i> RIGHT) HEADING (<i>three digits</i>); c) TRANSMIT FOR IDENTIFICATION AND REPORT HEADING; d) RADAR CONTACT [<i>position</i>]; e) IDENTIFIED [<i>position</i>]; f) NOT IDENTIFIED [<i>reason</i>], [RESUME (<i>or</i> CONTINUE) OWN NAVIGATION]. |
| 4.1.2 Position information | POSITION (<i>distance</i>) (<i>direction</i>) OF (<i>significant point</i>) (<i>or</i> OVER <i>or</i> ABEAM (<i>significant point</i>)). |
| 4.1.3 Vectoring instructions | <ul style="list-style-type: none"> a) LEAVE (<i>significant point</i>) HEADING (<i>three digits</i>) [INBOUND] AT (<i>time</i>); b) CONTINUE HEADING (<i>three digits</i>); c) CONTINUE PRESENT HEADING; d) FLY HEADING (<i>three digits</i>); e) TURN LEFT (<i>or</i> RIGHT) (<i>number</i>) DEGREES (<i>or</i> HEADING (<i>three digits</i>)) [<i>reason</i>]; f) STOP TURN HEADING (<i>three digits</i>); g) FLY HEADING (<i>three digits</i>), WHEN ABLE PROCEED DIRECT (<i>name</i>) (<i>navaid or way-point</i>); h) HEADING IS GOOD. |

| Circumstances | Phraseologies |
|--|---|
| 4.1.4 Termination of radar vectoring | a) RESUME OWN NAVIGATION (<i>position of aircraft</i>) (<i>specific instructions</i>); b) RESUME OWN NAVIGATION [DIRECT] (<i>significant point</i>) [MAGNETIC TRACK (<i>three digits</i>) DISTANCE (<i>number</i>) KILOMETRES (<i>or MILES</i>)]. |
| 4.1.5 Manoeuvres ... (in case of unreliable directional instruments on board aircraft) | a) MAKE A THREE SIXTY TURN LEFT (<i>or RIGHT</i>) [<i>reason</i>]; b) ORBIT LEFT (<i>or RIGHT</i>) [<i>reason</i>]; c) MAKE ALL TURNS RATE ONE (<i>or RATE HALF, or (number) DEGREES PER SECOND</i>) EXECUTE INSTRUCTIONS IMMEDIATELY UPON RECEIPT; d) TURN LEFT (<i>or RIGHT</i>) NOW; e) STOP TURN NOW. |
| <p><i>Note.— When it is necessary to specify a reason for radar vectoring or for the above manoeuvres, the following phraseologies should be used:</i></p> <p>a) DUE TRAFFIC; b) FOR SPACING; c) FOR DELAY; d) FOR DOWNWIND (<i>or BASE, or FINAL</i>).</p> | *a) SPEED (<i>number</i>) KILOMETRES PER HOUR (<i>or KNOTS</i>); b) REPORT SPEED; c) MAINTAIN (<i>number</i>) KILOMETRES PER HOUR (<i>or KNOTS</i>) UNTIL (<i>location</i>); d) MAINTAIN PRESENT SPEED; e) INCREASE (<i>or REDUCE</i>) SPEED TO (<i>number</i>) KILOMETRES PER HOUR (<i>or KNOTS</i>); f) INCREASE (<i>or REDUCE</i>) SPEED BY (<i>number</i>) KILOMETRES PER HOUR (<i>or KNOTS</i>); g) RESUME NORMAL SPEED; h) REDUCE TO MINIMUM APPROACH SPEED; i) REDUCE TO MINIMUM CLEAN SPEED; j) NO [ATC] SPEED RESTRICTIONS. |
| 4.1.6 Speed control | * Denotes pilot transmission. |

| <i>Circumstances</i> | <i>Phraseologies</i> |
|--|--|
| 4.1.7 Position reporting ... to omit position reports when under radar control | a) OMIT POSITION REPORTS [UNTIL (<i>specify</i>)]; b) NEXT REPORT AT (<i>significant point</i>); c) REPORTS REQUIRED ONLY AT (<i>location(s)</i>); d) RESUME POSITION REPORTING. |
| 4.1.8 Traffic information and avoiding action ... (if known) ... to request avoiding action ... when passing unknown traffic ... for avoiding action | a) TRAFFIC (<i>number</i>) O’CLOCK (<i>distance</i>) (<i>direction of flight</i>) [<i>any other pertinent information</i>]: 1) UNKNOWN; 2) SLOW MOVING; 3) FAST MOVING; 4) CLOSING; 5) OPPOSITE (<i>or</i> SAME) DIRECTION; 6) OVERTAKING; 7) CROSSING LEFT TO RIGHT (<i>or</i> RIGHT TO LEFT); 8) TYPE; 9) LEVEL; 10) CLIMBING (<i>or</i> DESCENDING); *b) REQUEST VECTORS; c) DO YOU WANT VECTORS?; d) CLEAR OF TRAFFIC [<i>appropriate instructions</i>]; e) TURN LEFT (<i>or</i> RIGHT) IMMEDIATELY [(<i>number</i>) DEGREES] <i>or</i> [HEADING (<i>three digits</i>)] TO AVOID [UNIDENTIFIED] TRAFFIC (<i>bearing by clock-reference and distance</i>). * Denotes pilot transmission. |

| <i>Circumstances</i> | <i>Phraseologies</i> |
|--|--|
| 4.1.9 Communications and loss of communications ... if loss of communications suspected | a) [IF] RADIO CONTACT LOST (<i>instructions</i>); b) IF NO TRANSMISSIONS RECEIVED FOR (<i>number</i>) MINUTES (or SECONDS) (<i>instructions</i>); c) REPLY NOT RECEIVED (<i>instructions</i>); d) IF YOU READ [<i>manoeuvre instructions or SQUAWK (code or IDENT)</i>]; e) (<i>manoeuvre or SQUAWK</i>) OBSERVED. POSITION (<i>position of aircraft</i>). WILL CONTINUE TO PASS INSTRUCTIONS. |
| 4.1.10 Termination of radar service | a) RADAR CONTROL TERMINATED [DUE (<i>reason</i>)]; b) RADAR SERVICE TERMINATED (<i>instructions</i>); c) WILL SHORTLY LOSE IDENTIFICATION (<i>appropriate instructions or information</i>); d) IDENTIFICATION LOST [<i>reasons</i>] (<i>instructions</i>). |

4.2 Radar in approach control service

| <i>Circumstances</i> | <i>Phraseologies</i> |
|--|--|
| 4.2.1 Vectoring for approach | a) VECTORING FOR (<i>type of pilot-interpreted aid</i>) APPROACH RUNWAY (<i>number</i>); b) VECTORING FOR VISUAL APPROACH RUNWAY (<i>number</i>) REPORT FIELD (or RUNWAY) IN SIGHT; c) VECTORING FOR (<i>positioning in the circuit</i>); d) VECTORING FOR SURVEILLANCE RADAR APPROACH RUNWAY (<i>number</i>); e) VECTORING FOR PRECISION APPROACH RUNWAY (<i>number</i>); f) (<i>type</i>) APPROACH NOT AVAILABLE DUE (<i>reason</i>) (<i>alternative instructions</i>). |
| 4.2.2 Vectoring for ILS and other pilot-interpreted aids | a) POSITION (<i>number</i>) KILOMETRES (or MILES) from (<i>fix</i>). TURN LEFT (or RIGHT) HEADING (<i>three digits</i>); b) YOU WILL INTERCEPT (<i>radio aid or track</i>) (<i>distance</i>) FROM (<i>significant point or TOUCHDOWN</i>); |

Circumstances

Phraseologies

... when a pilot wishes to be positioned a specific distance from touchdown

*c) REQUEST (*distance*) FINAL;

d) CLEARED FOR (*type*) APPROACH RUNWAY (*number*);

... instructions and information

e) REPORT ESTABLISHED [ON MLS APPROACH TRACK] *or* [ON ILS (LOCALIZER) *or* (GLIDE PATH)];

f) CLOSING FROM LEFT (*or* RIGHT) [REPORT ESTABLISHED];

g) TURN LEFT (*or* RIGHT) HEADING (*three digits*) [TO INTERCEPT] *or* [REPORT ESTABLISHED];

h) EXPECT VECTOR ACROSS (*localizer course or aid*) (*reason*);

i) THIS TURN WILL TAKE YOU THROUGH (*aid*) [*reason*];

j) TAKING YOU THROUGH (*aid*) [*reason*];

k) MAINTAIN (*altitude*) UNTIL GLIDE PATH INTERCEPTION;

l) REPORT ESTABLISHED ON GLIDE PATH;

m) INTERCEPT (*radio aid*) [REPORT ESTABLISHED].

* Denotes pilot transmission.

4.2.3 Manoeuvre during independent and dependent parallel approaches

a) CLEARED FOR ILS (*or* MLS) APPROACH RUNWAY (*number*) LEFT (*or* RIGHT);

b) YOU HAVE CROSSED THE LOCALIZER (*or* MLS FINAL APPROACH TRACK). TURN LEFT (*or* RIGHT) IMMEDIATELY AND RETURN TO THE LOCALIZER (*or* MLS FINAL APPROACH TRACK);

c) ILS (*or* MLS) RUNWAY (*number*) LEFT (*or* RIGHT) LOCALIZER (*or* MLS) FREQUENCY IS (*frequency*);

... for avoidance action when an aircraft is observed penetrating the NTZ

d) TURN LEFT (*or* RIGHT) (*number*) DEGREES (*or* HEADING) (*three digits*) IMMEDIATELY TO AVOID TRAFFIC [DEVIATING FROM ADJACENT APPROACH], CLIMB TO (*altitude*).

| <i>Circumstances</i> | <i>Phraseologies</i> |
|-----------------------------------|--|
| 4.2.4 Surveillance radar approach | a) THIS WILL BE A SURVEILLANCE RADAR APPROACH RUNWAY (<i>number</i>) TERMINATING AT (<i>distance</i>) FROM TOUCHDOWN, OBSTACLE CLEARANCE ALTITUDE (<i>or</i>) HEIGHT (<i>number</i>) METRES (<i>or</i>) FEET CHECK YOUR MINIMA [IN CASE OF GO AROUND (<i>instructions</i>)]; b) APPROACH INSTRUCTIONS WILL BE TERMINATED AT (<i>distance</i>) FROM TOUCHDOWN. |
| 4.2.4.1 Provision of service | a) COMMENCE DESCENT NOW [TO MAINTAIN A (<i>number</i>) DEGREE GLIDE PATH]; b) (<i>distance</i>) FROM TOUCHDOWN ALTITUDE (<i>or</i>) HEIGHT SHOULD BE (<i>numbers and units</i>). |
| 4.2.4.2 Elevation | (<i>distance</i>) FROM TOUCHDOWN. |
| 4.2.4.3 Position | a) CHECK GEAR DOWN; b) OVER THRESHOLD. |
| 4.2.4.4 Checks | a) REPORT VISUAL; b) REPORT RUNWAY [LIGHTS] IN SIGHT; c) APPROACH COMPLETED [CONTACT (<i>unit</i>)]. |
| 4.2.4.5 Completion of approach | a) THIS WILL BE A PRECISION RADAR APPROACH RUNWAY (<i>number</i>); b) PRECISION APPROACH NOT AVAILABLE DUE (<i>reason</i>) (<i>alternative instructions</i>); c) IN CASE OF GO AROUND (<i>instructions</i>). |
| 4.2.5 PAR approach | a) DO NOT ACKNOWLEDGE FURTHER TRANSMISSIONS; b) REPLY NOT RECEIVED. WILL CONTINUE INSTRUCTIONS. |
| 4.2.5.1 Provision of service | a) CLOSING [SLOWLY (<i>or</i>) QUICKLY] [FROM THE LEFT (<i>or</i>) FROM THE RIGHT]; b) HEADING IS GOOD; |
| 4.2.5.2 Communications | a) CLOSING [SLOWLY (<i>or</i>) QUICKLY] [FROM THE LEFT (<i>or</i>) FROM THE RIGHT]; b) HEADING IS GOOD; |
| 4.2.5.3 Azimuth | |

| <i>Circumstances</i> | <i>Phraseologies</i> |
|----------------------|---|
| | <ul style="list-style-type: none"> c) ON TRACK; d) SLIGHTLY (<i>or WELL, or GOING</i>) LEFT (<i>or RIGHT</i>) OF TRACK; e) (<i>number</i>) METRES LEFT (<i>or RIGHT</i>) OF TRACK. |
| 4.2.5.4 Elevation | <ul style="list-style-type: none"> a) APPROACHING GLIDE PATH; b) COMMENCE DESCENT NOW [AT (<i>number</i>) METRES PER SECOND OR (<i>number</i>) FEET PER MINUTE (<i>or ESTABLISH A (number) DEGREE GLIDE PATH</i>)]; c) RATE OF DESCENT IS GOOD; d) ON GLIDE PATH; e) SLIGHTLY (<i>or WELL, or GOING</i>) ABOVE (<i>or BELOW</i>) GLIDE PATH; f) [STILL] (<i>number</i>) METRES (<i>or FEET</i>) TOO HIGH (<i>or TOO LOW</i>); g) ADJUST RATE OF DESCENT; h) COMING BACK [SLOWLY (<i>or QUICKLY</i>)] TO THE GLIDE PATH; i) RESUME NORMAL RATE OF DESCENT; j) ELEVATION ELEMENT UNSERVICEABLE (<i>to be followed by appropriate instructions</i>); k) (<i>distance</i>) FROM TOUCHDOWN. ALTITUDE (<i>or HEIGHT</i>) SHOULD BE (<i>numbers and units</i>). |
| 4.2.5.5 Position | <ul style="list-style-type: none"> a) (<i>distance</i>) FROM TOUCHDOWN; b) OVER APPROACH LIGHTS; c) OVER THRESHOLD. |
| 4.2.5.6 Checks | <ul style="list-style-type: none"> a) CHECK GEAR DOWN AND LOCKED; b) CHECK DECISION ALTITUDE (<i>or HEIGHT</i>). |

| <i>Circumstances</i> | <i>Phraseologies</i> |
|--------------------------------|---|
| 4.2.5.7 Completion of approach | a) REPORT VISUAL; b) REPORT RUNWAY [LIGHTS] IN SIGHT; c) APPROACH COMPLETED [CONTACT (<i>unit</i>)]. |
| 4.2.5.8 Missed approach | a) CONTINUE VISUALLY OR GO AROUND [<i>missed approach instructions</i>]; b) GO AROUND IMMEDIATELY [<i>missed approach instructions</i>] (<i>reason</i>); c) ARE YOU GOING AROUND?; d) IF GOING AROUND (<i>appropriate instructions</i>); *e) GOING AROUND. * Denotes pilot transmission. |

4.3 *Secondary surveillance radar phraseologies*

| <i>Circumstances</i> | <i>Phraseologies</i> |
|---|---|
| 4.3.1 To request the capability of the SSR equipment | a) ADVISE TYPE OF TRANSPONDER; *b) TRANSPONDER (<i>as shown in the flight plan</i>); *c) NEGATIVE TRANSPONDER. * Denotes pilot transmission. |
| 4.3.2 To instruct setting of transponder | a) FOR DEPARTURE SQUAWK (<i>code</i>); b) SQUAWK (<i>code</i>). |
| 4.3.3 To request the pilot to reselect the assigned mode and code | a) RECYCLE (<i>mode</i>) (<i>code</i>); *b) RECYCLING (<i>mode</i>) (<i>code</i>). * Denotes pilot transmission. |
| 4.3.4 To request reselection of aircraft identification | RESET MODE S IDENTIFICATION. |

| <i>Circumstances</i> | <i>Phraseologies</i> |
|--|---|
| 4.3.5 To request the pilot to confirm the Mode A Code selected on the aircraft's transponder | a) CONFIRM SQUAWK (<i>code</i>); *b) SQUAWKING (<i>code</i>). * Denotes pilot transmission. |
| 4.3.6 To request the operation of the IDENT feature | a) SQUAWK IDENT; b) SQUAWK LOW; c) SQUAWK NORMAL. |
| 4.3.7 To request temporary suspension of transponder operation | SQUAWK STANDBY. |
| 4.3.8 To request emergency code | SQUAWK MAYDAY. |
| 4.3.9 To request termination of transponder operation | STOP SQUAWK. |
| 4.3.10 To request transmission of pressure altitude | SQUAWK CHARLIE. |
| 4.3.11 To request pressure setting check and confirmation of level | CHECK ALTIMETER SETTING AND CONFIRM LEVEL. |
| 4.3.12 To request termination of pressure altitude transmission because of faulty operation | STOP SQUAWK CHARLIE WRONG INDICATION. |
| 4.3.13 To request altitude check | VERIFY (<i>level</i>). |

Note.— Other phraseologies for use in the area control radar service are given in the section containing approach control radar service phraseologies.

PART XI. CONTROLLER-PILOT DATA LINK COMMUNICATIONS (CPDLC)

1. General

1.1 The CPDLC application provides a means of communication between the controller and pilot, using data link for ATC communication.

1.2 This application includes a set of clearance/information/request message elements which correspond to the phraseologies used in the radiotelephony environment.

Note.— See Appendix 5 for the CPDLC message set which lists the message elements and their respective message intents/use.

1.2.1 The controller shall be provided with the capability to issue level assignments, crossing constraints, lateral deviations, route clearances and amendments thereto, speed assignments, radio frequency assignments, and requests for information via CPDLC.

1.2.2 The pilot shall be provided with the capability to respond to messages, to request clearances and information, to report information, and to declare or cancel an emergency.

1.2.3 The pilot and the controller shall be provided with the capability to exchange “free text” messages which do not conform to defined formats.

1.2.4 Sending a message by CPDLC shall consist of selecting the recipient(s), selecting the appropriate message, and executing the transmission.

1.2.5 Wherever time is used in the application of CPDLC, it shall be accurate to within 1 second of UTC.

1.3 Where applicable, the communication procedures for the provision of CPDLC shall be in accordance with Annex 10, Volume III, Part I, Chapter 3. Message element intent and text and associated procedures are, in general, consistent with Part X — Phraseologies. It is, however, recognized that the CPDLC message set and the associated procedures differ somewhat from the voice equivalent used because of the differences between the two media; one being direct-speech and the other an exchange of data, the latter of which can be displayed and/or printed.

2. Communication procedures

2.1 The controller or pilot shall initiate data messages using either the defined message set, a free text message or a combination of both.

Note.— See Appendix 5 for the CPDLC message set including message intent/use and the respective message elements.

2.2 Ground and airborne systems shall allow for messages to be appropriately displayed, printed when required and stored in a manner that permits timely and convenient retrieval should such action be necessary. Whenever textual presentation is required, the English language shall be used as a minimum.

2.3 Message attributes

2.3.1 Message attributes dictate certain message handling requirements for the CPDLC user receiving a message. Each CPDLC message has three attributes: Urgency, Alert and Response.

2.3.2 Urgency

2.3.2.1 The urgency (URG) attribute delineates the queuing requirements for received messages that are displayed to the end-user. Urgency types are presented in Table XI-1.

2.3.3 Alert

2.3.3.1 The alert (ALRT) attribute delineates the type of alerting required upon message receipt. Alert types are presented in Table XI-2.

2.3.4 Response

2.3.4.1 The response (RESP) attribute mandates response requirements for a given message element. Response types are presented in Table XI-3 for uplink messages and Table XI-4 for downlink messages.

**Table XI-1. Urgency attribute
(uplink and downlink)**

| <i>Type</i> | <i>Description</i> | <i>Precedence</i> |
|-------------|--------------------|-------------------|
| D | Distress | 1 |
| U | Urgent | 2 |
| N | Normal | 3 |
| L | Low | 4 |

**Table XI-2. Alert attribute
(uplink and downlink)**

| <i>Type</i> | <i>Description</i> | <i>Precedence</i> |
|-------------|----------------------|-------------------|
| H | High | 1 |
| M | Medium | 2 |
| L | Low | 3 |
| N | No alerting required | 4 |

Table XI-3. Response attribute (uplink)

| <i>Type</i> | <i>Response required</i> | <i>Valid responses</i> | <i>Precedence</i> |
|-------------|---|---|-------------------|
| W/U | Yes | WILCO, UNABLE, STANDBY permitted, LOGICAL ACKNOWLEDGEMENT (only if required), ERROR (if necessary) | 1 |
| A/N | Yes | AFFIRM, NEGATIVE, STANDBY permitted, LOGICAL ACKNOWLEDGEMENT (only if required), ERROR (if necessary) | 2 |
| R | Yes | ROGER, UNABLE, STANDBY permitted, LOGICAL ACKNOWLEDGEMENT (only if required), ERROR (if necessary) | 3 |
| Y | Yes | Any CPDLC downlink message, LOGICAL ACKNOWLEDGEMENT (only if required) | 4 |
| N | No, unless logical acknowledgement required | LOGICAL ACKNOWLEDGEMENT (only if required), ERROR (if necessary, only when logical acknowledgement is required) | 5 |

Table XI-4. Response attribute (downlink)

| <i>Type</i> | <i>Response required</i> | <i>Valid responses</i> | <i>Precedence</i> |
|-------------|---|---|-------------------|
| Y | Yes | Any CPDLC uplink message, LOGICAL ACKNOWLEDGEMENT (only if required) | 1 |
| N | No, unless logical acknowledgement required | LOGICAL ACKNOWLEDGEMENT (only if required), ERROR (if necessary, only when logical acknowledgement is required) | 2 |

APPENDIX 1. INSTRUCTIONS FOR AIR-REPORTING BY VOICE COMMUNICATIONS

1. Reporting instructions
2. Special air-report of volcanic activity form (Model VAR)
3. Examples

1. Reporting instructions

MODEL AIREP/AIREP SPECIAL

| ITEM | PARAMETER | TRANSMIT IN TELEPHONY as appropriate |
|------|--|--------------------------------------|
| — | Message-type designator: • routine air-report • special air-report | [AIREP] [AIREP] SPECIAL |

| | | | | |
|-----------|----|---|---|---------|
| Section 1 | 1 | Aircraft identification | <i>(aircraft identification)</i> | |
| | 2 | Position | POSITION <i>(latitude and longitude)</i> OVER <i>(significant point)</i> ABEAM <i>(significant point)</i> <i>(significant point) (bearing) (distance)</i> | |
| | 3 | Time | <i>(time)</i> | |
| | 4 | Flight level or altitude | FLIGHT LEVEL <i>(number)</i> or <i>(number)</i> METRES or FEET CLIMBING TO FLIGHT LEVEL <i>(number)</i> or <i>(number)</i> METRES or FEET DESCENDING TO FLIGHT LEVEL <i>(number)</i> or <i>(number)</i> METRES or FEET | |
| | 5 | Next position and estimated time over | <i>(position) (time)</i> | |
| | 6 | Ensuing significant point | <i>(position)</i> NEXT | |
| Section 2 | 7 | Estimated time of arrival | <i>(aerodrome) (time)</i> | |
| | 8 | Endurance | ENDURANCE <i>(hours and minutes)</i> | |
| Section 3 | 9 | Air temperature | TEMPERATURE PLUS <i>(degrees Celsius)</i> TEMPERATURE MINUS <i>(degrees Celsius)</i> | |
| | 10 | Wind direction | WIND <i>(number)</i> DEGREES | or CALM |
| | 11 | Wind speed | <i>(number)</i> KILOMETRES PER HOUR or KNOTS | |
| | 12 | Turbulence | TURBULENCE LIGHT TURBULENCE MODERATE TURBULENCE SEVERE | |
| | 13 | Aircraft icing | ICING LIGHT ICING MODERATE ICING SEVERE | |
| | 14 | Humidity (if available) | HUMIDITY <i>(per cent)</i> | |
| | 15 | Phenomenon encountered or observed, prompting a special air-report: • Severe turbulence • Severe icing • Severe mountainwave • Thunderstorms without hail • Thunderstorms with hail • Heavy dust/sandstorm • Volcanic ash cloud • Pre-eruption volcanic activity or volcanic eruption SST: • Moderate turbulence • Hail • Cumulonimbus clouds | TURBULENCE SEVERE ICING SEVERE MOUNTAINWAVE SEVERE THUNDERSTORMS THUNDERSTORMS WITH HAIL DUSTSTORM or SANDSTORM HEAVY VOLCANIC ASH CLOUD PRE-ERUPTION VOLCANIC ACTIVITY or VOLCANIC ERUPTION TURBULENCE MODERATE HAIL CB CLOUDS | |

1. Routine air-reports

1.1 Section 1 is obligatory, although Items 5 and 6 thereof may be omitted when prescribed in *Regional Supplementary Procedures*; Section 2 shall be added, in whole or in part, only when so requested by the operator or his designated representative, or when deemed necessary by the pilot-in-command; Section 3 shall be added in accordance with Annex 3 and the *Regional Supplementary Procedures*, Part 3 — *Meteorology*.

1.2 Section 3 shall include all Items 9 to 13 and Item 14, if available.

2. Special air-reports

2.1 Special air-reports shall be made whenever any of the phenomena listed under Item 15 are observed or encountered. Items 1 to 4 of Section 1 and the appropriate phenomenon specified in Section 3, Item 15, are required from all aircraft. The phenomena listed under "SST" shall be reported only by supersonic transport at transonic and supersonic cruising levels.

2.2 In the case of special air-reports containing information on volcanic activity, a post-flight report shall be made on the volcanic activity reporting form (Model VAR). All elements which are observed shall be recorded and indicated respectively in the appropriate places on the form Model VAR.

2.3 Special air-reports shall be made as soon as practicable after a phenomenon calling for a special air-report has been observed.

2.4 If a phenomenon warranting the making of a special air-report is observed at or near the time or place where a routine air-report is to be made, a special air-report shall be made instead.

3. Detailed reporting instructions

3.1 Items of an air-report shall be reported in the order in which they are listed in the model AIREP/AIREP SPECIAL form.

— MESSAGE TYPE DESIGNATOR. Report "SPECIAL" for a special air-report.

Section 1

Item 1 — AIRCRAFT IDENTIFICATION. Report the aircraft radiotelephony call sign as prescribed in Annex 10, Chapter 5.

Item 2 — POSITION. Report position in latitude (degrees as 2 numerics or degrees and minutes as 4 numerics, followed by "North" or "South") and longitude (degrees as 3 numerics or degrees and minutes as 5 numerics, followed by "East" or "West"), or as a significant point identified by a coded designator (2 to 5 characters), or as a significant point followed by magnetic bearing (3 numerics) and distance in nautical miles from the point (e.g. "4620North07805West", "4620North07800West", "4600North07800West", LN ("LIMA NOVEMBER"), "MAY", "HADDY" or "DUB 180 DEGREES 40 MILES"). Precede significant point by "ABEAM", if applicable.

Item 3 — TIME. Report time in hours and minutes UTC (4 numerics) unless reporting time in minutes past the hour (2 numerics) is prescribed on the basis of regional air navigation agreements. The time reported must be the actual time of the aircraft at the position and not the time of origination or transmission of the report. Time shall always be reported in hours and minutes UTC when making a special air-report.

Item 4 — FLIGHT LEVEL OR ALTITUDE. Report flight level by 3 numerics (e.g. "FLIGHT LEVEL 310"), when on standard pressure altimeter setting. Report altitude in metres followed by "METRES" or in feet followed by "FEET", when on QNH. Report "CLIMBING" (followed by the level) when climbing, or "DESCENDING" (followed by the level) when descending, to a new level after passing the significant point.

Item 5 — NEXT POSITION AND ESTIMATED TIME OVER. Report the next reporting point and the estimated time over such reporting point, or report the estimated position that will be reached one hour later, according to the position reporting procedures in force. Use the data conventions specified in Item 2 for position. Report the estimated time over this position. Report time in hours and minutes UTC (4 numerics) unless reporting time in minutes past the hour (2 numerics) as prescribed on the basis of regional air navigation agreements.

Item 6 — ENSUING SIGNIFICANT POINT. Report the ensuing significant point following the "next position and estimated time over".

Section 2

Item 7 — ESTIMATED TIME OF ARRIVAL. Report the name of the aerodrome of the first intended landing, followed by the estimated time of arrival at this aerodrome in hours and minutes UTC (4 numerics).

Item 8 — ENDURANCE. Report "ENDURANCE" followed by fuel endurance in hours and minutes (4 numerics).

Section 3

Item 9 — AIR TEMPERATURE. Report "TEMPERATURE PLUS" or "TEMPERATURE MINUS" followed by the temperature in degrees Celsius (2 numerics), corrected for instrument error and airspeed (e.g. TEMPERATURE MINUS 05).

Item 10 — WIND DIRECTION.

Item 11 — WIND SPEED. Report spot wind referring to the position given in Item 2. Report wind direction in degrees true (3 numerics) and wind speed in kilometres per hour or knots (2 or 3 numerics) (e.g. WIND 345 DEGREES 55 KILOMETRES PER HOUR, WIND 170 DEGREES 65 KNOTS). Report calm conditions as "CALM".

Item 12 — TURBULENCE. Report severe turbulence as "TURBULENCE SEVERE", moderate turbulence as "TURBULENCE MODERATE" and light turbulence as "TURBULENCE LIGHT".

The following specifications apply:

Light — Conditions less than moderate turbulence. Changes in accelerometer readings less than 0.5 g at the aircraft's centre of gravity.

Moderate — Conditions in which moderate changes in aircraft attitude and/or altitude may occur but the aircraft remains in positive control at all times. Usually, small variations in air speed. Changes in accelerometer readings of 0.5 g to 1.0 g at the aircraft's centre of gravity. Difficulty in walking. Occupants feel strain against seat belts. Loose objects move about.

Severe — Conditions in which abrupt changes in aircraft attitude and/or altitude occur; aircraft may be out of control for short periods. Usually, large variations in air speed. Changes in accelerometer readings greater than 1.0 g at the aircraft's centre of gravity. Occupants are forced violently against seat belts. Loose objects are tossed about.

Item 13 — AIRCRAFT ICING. Report severe icing as "ICING SEVERE", moderate icing as "ICING MODERATE" and light icing as "ICING LIGHT".

The following specifications apply:

Light — Conditions less than moderate icing.

Moderate — Conditions in which change of heading and/or altitude may be considered desirable.

Severe — Conditions in which immediate change of heading and/or altitude is considered essential.

Item 14 — HUMIDITY. Report the relative humidity, if available, as "HUMIDITY" followed by the relative humidity in per cent (3 numerics) (e.g. HUMIDITY 085).

Item 15 — PHENOMENON PROMPTING A SPECIAL AIR-REPORT. Report one of the following phenomena encountered or observed:

- severe turbulence as "TURBULENCE SEVERE" Specifications under Item 12 apply.
- severe icing as "ICING SEVERE" Specifications under Item 13 apply.
- severe mountainwave as "MOUNTAINWAVE SEVERE" The following specification applies: severe — conditions in which the accompanying downdraft is 3.0 m/s (600 ft/min) or more and/or severe turbulence is encountered.
- thunderstorm without hail as "THUNDERSTORM"
- thunderstorm with hail as "THUNDERSTORM WITH HAIL" The following specification applies: Only report those thunderstorms which are:

- obscured in haze; or
 - embedded in cloud; or
 - widespread; or
 - forming a squall-line.
- heavy duststorm or sandstorm as "DUSTSTORM or SANDSTORM HEAVY"

- volcanic ash cloud as "VOLCANIC ASH CLOUD"
- pre-eruption volcanic activity or a volcanic eruption as "PRE-ERUPTION VOLCANIC ACTIVITY or VOLCANIC ERUPTION"

The following specifications apply:

Pre-eruption volcanic activity in this context means unusual and/or increasing volcanic activity which could presage a volcanic eruption.

Note.— In case of volcanic ash cloud, pre-eruption volcanic activity or volcanic eruption, in accordance with Part II, 15.6, a post-flight report shall also be made on the special air-report of volcanic activity form (Model VAR).

The following phenomena shall be reported only by supersonic transport at transonic levels and supersonic cruising levels:

- moderate turbulence as "TURBULENCE MODERATE"
Specifications under Item 12 apply.
- hail as "HAIL"
- cumulonimbus clouds as "CB CLOUDS".

3.2 Information recorded on the volcanic activity reporting form (Model VAR) is not for transmission by RTF but, on arrival at an aerodrome, is to be delivered without delay by the operator or a flight crew member to the aerodrome meteorological office. If such an office is not easily accessible, the completed form shall be delivered in accordance with local arrangements made between the Meteorological and ATS Authorities and the operator.

4. Forwarding of meteorological information received by voice communications

4.1 When receiving routine or special air-reports, air traffic services units shall forward these air-reports without delay to the associated meteorological watch office (MWO). In order to ensure assimilation of air-reports in ground-based automated systems, the elements of such reports shall be transmitted using the data conventions specified below and in the order prescribed.

- ADDRESSEE. Record station called and, when necessary, relay required.
- MESSAGE TYPE DESIGNATOR. Record "ARS" for a special air-report.

Note.— Where air-reports are handled by automatic data processing equipment which cannot accept this message-type designator, in accordance with Part IX, 4.2.5.5.2, the use of a different message-type designator is permitted by regional air navigation agreement.

- AIRCRAFT IDENTIFICATION. Record the aircraft identification using the data convention specified for Item 7 of the flight plan, without a space between the operator's designator and the aircraft registration or flight identification, if used (e.g. New Zealand 103 as ANZ103).

Rules of the Air and Air Traffic Services (PANS-RAC)

Section 1

Item 0 — POSITION. Record position in latitude (degrees as 2 numerics or degrees and minutes as 4 numerics, followed without a space by N or S) and longitude (degrees as 3 numerics or degrees and minutes as 5 numerics, followed without a space by E or W), or as a significant point identified by a coded designator (2 to 5 characters), or as a significant point followed by magnetic bearing (3 numerics) and distance in nautical miles (3 numerics) from the point (e.g. 4620N07805W, 4620N078W, 46N078W, LN, MAY, HADDY or DUB180040). Precede significant point by "ABM" (abeam), if applicable.

Item 1 — TIME. Record time in hours and minutes UTC (4 numerics).

Item 2 — FLIGHT LEVEL OR ALTITUDE. Record F followed by 3 numerics (e.g. F310), when a flight level is reported. Record altitude in metres followed by M or in feet followed by FT, when an altitude is reported. Record "ASC" (level) when climbing, or "DES" (level) when descending.

Section 3

Item 8 — AIR TEMPERATURE. Record "PS" (plus) or "MS" (minus) followed, without a space, by the temperature in degrees Celsius (2 numerics) (e.g. MS05).

Item 9 — WIND DIRECTION.

Item 10 — WIND SPEED. Record wind direction in degrees true (3 numerics) and wind speed in kilometres per hour or knots (2 or 3 numerics), separated by an oblique stroke, indicating the unit used (e.g. 345/55KMH, 170/65KT). Record calm as "00000".

Item 11 — TURBULENCE. Record severe turbulence as TURB SEV and moderate turbulence as TURB MOD and light turbulence as TURB FBL.

Item 12 — AIRCRAFT ICING. Record severe icing as ICE SEV, moderate icing as ICE MOD and light icing as ICE FBL.

Item 13 — HUMIDITY. If reported, record "RH" followed, without a space, by the humidity in per cent (3 numerics, e.g. RH085).

Note.— Item 13 is optional and shall be included only when available.

Item 14 — PHENOMENON PROMPTING A SPECIAL AIR-REPORT. Record the phenomenon reported as follows:

- severe turbulence as "TURB SEV"
- severe icing as "ICE SEV"
- severe mountainwave as "MTW SEV"
- thunderstorm without hail as "TS"
- thunderstorm with hail as "TSGR"
- heavy duststorm or sandstorm as "HVV SS"
- volcanic ash cloud as "VA CLD"
- pre-eruption volcanic activity or a volcanic eruption as "VA"
- moderate turbulence as "TURB MOD"
- hail as "GR"
- cumulonimbus clouds as "CB".

— TIME TRANSMITTED. Record only when Section 3 is transmitted.

2. Special air-report of volcanic activity form (Model VAR)
MODEL VAR: to be used for post-flight reporting

Operator: Aircraft identification (as per item 7 of flight plan): Pilot-in-command: Dep. from Date Time UTC
 Arr. at Date Time UTC

| | |
|-----------|---------------|
| Addressee | |
| | AIREP SPECIAL |

| | | |
|-----------|--|--|
| Section 1 | 1 Aircraft identification | |
| | 2 Position | |
| | 3 Time | |
| | 4 Flight level or altitude | |
| | 5 VOLCANIC ACTIVITY OBSERVED AT | (position or bearing and distance from aircraft) |
| | 6 Air temperature | |
| | 7 Spot wind | |
| | 8 Supplementary information <small>(Brief description of activity including vertical and lateral extent of ash cloud, horizontal movement, rate of growth, etc. as available)</small> | |

| | |
|--|---|
| The following information is not for transmission by RTF | |
| | TICK <input checked="" type="checkbox"/> THE APPROPRIATE BOX |
| Section 2 | 9 Density of ash cloud (a) wispy <input type="checkbox"/> (b) moderate dense <input type="checkbox"/> (c) very dense <input type="checkbox"/> |
| | 10 Colour of ash cloud (a) white <input type="checkbox"/> (b) light grey <input type="checkbox"/> (c) dark grey <input type="checkbox"/> (d) black <input type="checkbox"/> |
| | 11 Eruption (a) continuous <input type="checkbox"/> (b) intermittent <input type="checkbox"/> (c) not visible <input type="checkbox"/> |
| | 12 Position of activity (a) summit <input type="checkbox"/> (b) side <input type="checkbox"/> (c) single <input type="checkbox"/> (d) multiple <input type="checkbox"/> (e) not observed <input type="checkbox"/> |
| | 13 Other observed features of eruption (a) lightning <input type="checkbox"/> (b) glow <input type="checkbox"/> (c) large rocks <input type="checkbox"/> (d) ash fall out <input type="checkbox"/> (e) mushrooming cloud <input type="checkbox"/> (f) nil <input type="checkbox"/> |
| | 14 Effect on aircraft (a) communications <input type="checkbox"/> (b) nav. systems <input type="checkbox"/> (c) engines <input type="checkbox"/> (d) pitot static <input type="checkbox"/> (e) windscreen <input type="checkbox"/> (f) windows <input type="checkbox"/> (g) nil <input type="checkbox"/> |
| | 15 Other effects (a) turbulence <input type="checkbox"/> (b) St. Elmos Fire <input type="checkbox"/> (c) fumes <input type="checkbox"/> (d) ash deposits <input type="checkbox"/> |
| | 16 Other information (Add any information considered useful.) |

3. Examples**AS SPOKEN IN RADIOTELEPHONY**

- I.-¹ AIREP SPEEDBIRD FIFE SIX AIT POSITION FOWer NINer TOO FIFE NORTH ZERO FIFE ZERO WEST AT WUN TREE WUN SEVen FLIGHT LEVEL TREE WUN ZERO NEXT POSITION FIFE ZERO NORTH ZERO FOWer ZERO WEST AT WUN TREE FIFE FIFE FOLLOWING POINT FIFE ZERO NORTH ZERO TREE ZERO WEST ENDURANCE ZERO AIT TREE ZERO TEMPERATURE MINUS FOWer SEVen WIND TOO FIFE FIFE DEGREES SIX FIFE KNOTS TURBULENCE MODERATE ICING LIGHT
- II.-² JAPANAIR FOWer FOWer WUN OVER ORDON AT ZERO NINer TREE ZERO FLIGHT LEVEL TREE FIFE ZERO NEXT POSITION ONADE AT WUN ZERO ZERO SEVen FOLLOWING POINT OMPPA TEMPERATURE MINUS FIFE TREE WIND TREE WUN ZERO DEGREES SIX ZERO KILOMETRES PER HOUR TURBULENCE LIGHT ICING LIGHT
- III.-³ AIREP SPECIAL CLIPPER WUN ZERO WUN POSITION FIFE ZERO FOWer FIFE NORTH ZERO TOO ZERO WUN FIFE WEST AT WUN FIFE TREE SIX FLIGHT LEVEL TREE WUN ZERO CLIMBING TO FLIGHT LEVEL TREE FIFE ZERO THUNDERSTORM WITH HAIL
- IV.-⁴ SPECIAL NIUGINI TOO SEVen TREE OVER MADANG AT ZERO AIT FOWer SIX WUN NINer TOUSAND FEET TURBULENCE SEVERE

AS RECORDED BY THE AIR TRAFFIC SERVICES UNIT AND FORWARDED TO THE METEOROLOGICAL OFFICE CONCERNED

- I.- BAW568 4925N050W 1317 F310 MS47 255/65KT
TURB MOD ICE FBL
- II.- JAL441 ORDON 0930 F350 MS53 310/60KMH
TURB FBL ICE FBL
- III.- ARS PAA101 5045N02015W 1536 F310 ASC F350
TSGR
- IV.- ARS ANG273 MD 0846 19000FT TURB SEV

-
1. A routine air-report for a trans-oceanic flight which has been designated to report routine meteorological observations at meridians spaced at intervals of 10 degrees. The information of the next position, ensuing significant point and endurance are not required for transmission to the meteorological offices concerned.
 2. A routine air-report for a trans-oceanic flight which is required to report routine meteorological observations at specified significant points. The information of the next position and the ensuing significant point are not required for transmission to the meteorological offices concerned.
 3. A special air-report which is required because of the occurrence of wide-spread thunderstorms with hail.
 4. A special air-report which is required because of severe turbulence. The aircraft is on QNH altimeter setting.
-

APPENDIX 2. FLIGHT PLAN

1. ICAO model flight plan form
2. Instructions for the completion of the flight plan form
3. Instructions for the transmission of a filed flight plan (FPL) message
4. Instructions for the transmission of a supplementary flight plan (SPL) message
5. Example of a completed flight plan form
6. ICAO model repetitive flight plan (RPL) listing form
7. Instructions for the completion of the repetitive flight plan (RPL) listing form
8. Example of a completed repetitive flight plan (RPL) listing form

1. ICAO model flight plan form

| FLIGHT PLAN PLAN DE VOL | | | |
|--|--|---|---|
| PRIORITY Priorité <<< FF >>> | ADDRESSEE(S) Destinataire(s) | | |
| FILING TIME Heure de dépôt | ORIGINATOR Expéditeur | | |
| SPECIFIC IDENTIFICATION OF ADDRESSEE(S) AND/OR ORIGINATOR Identification précise du(des) destinataire(s) et/ou de l'expéditeur | | | |
| 3 MESSAGE TYPE Type de message <<< (FPL) >>> | 7 AIRCRAFT IDENTIFICATION Identification de l'aéronef | 8 FLIGHT RULES Règles de vol | TYPE OF FLIGHT Type de vol |
| 9 NUMBER Nombre | TYPE OF AIRCRAFT Type d'aéronef | WAKE TURBULENCE CAT. Cat. de turbulence de sillage | 10 EQUIPMENT Équipement |
| 13 DEPARTURE AERODROME Aérodrome de départ | TIME Heure | 15 CRUISING SPEED Vitesse croisière | |
| LEVEL Niveau | | ROUTE Route | |
| 16 DESTINATION AERODROME Aérodrome de destination | | | |
| 18 OTHER INFORMATION Renseignements divers | | TOTAL EET Durée totale estimée HR. MIN | ALTN AERODROME Aérodrome de dégagement |
| 2ND. ALTN AERODROME 2ème aérodrome de dégagement | | | |
| SUPPLEMENTARY INFORMATION (NOT TO BE TRANSMITTED IN FPL MESSAGES) Renseignements complémentaires (À NE PAS TRANSMETTRE DANS LES MESSAGES DE PLAN DE VOL DÉPOSÉ) | | | |
| 19 ENDURANCE Autonomie HR. MIN | PERSONS ON BOARD Personnes à bord | EMERGENCY RADIO Radio de secours | |
| SURVIVAL EQUIPMENT/Équipement de survie | JACKETS/Gilets de sauvetage | UHF U | VHF V |
| POLAR Polaire S | DESERT Désert D | LIGHT Lampes L | ELT E |
| MARITIME Maritime M | JUNGLE Jungle J | FLUORES Fluores F | UHF U |
| DINGHIES/Canots | COLOUR Couleur | UHF U | VHF V |
| NUMBER Nombre | CAPACITY Capacité | AIRCRAFT COLOUR AND MARKINGS Couleur et marques de l'aéronef | |
| COVER Couverture | REMARKS Remarques | | |
| PILOT-IN-COMMAND Pilote commandant de bord | | | |
| FILED BY/Déposé par | | | |
| SPACE RESERVED FOR ADDITIONAL REQUIREMENTS Espace réservé à des fins supplémentaires | | | |

2. Instructions for the completion of the flight plan form

2.1 General

Adhere closely to the prescribed formats and manner of specifying data.

Commence inserting data in the first space provided. Where excess space is available, leave unused spaces blank.

Insert all clock times in *4 figures UTC*.

Insert all estimated elapsed times in 4 figures (hours and minutes).

Shaded area preceding Item 3 — to be completed by ATS and COM services, unless the responsibility for originating flight plan messages has been delegated.

Note.— The term “aerodrome” where used in the flight plan is intended to cover also sites other than aerodromes which may be used by certain types of aircraft, e.g. helicopters or balloons.

2.2 Instructions for insertion of ATS data

Complete Items 7 to 18 as indicated hereunder.

Complete also Item 19 as indicated hereunder, when so required by the appropriate ATS authority or when otherwise deemed necessary.

Note.— Item numbers on the form are not consecutive, as they correspond to Field Type numbers in ATS messages.

ITEM 7: AIRCRAFT IDENTIFICATION (MAXIMUM 7 CHARACTERS)

INSERT one of the following aircraft identifications, not exceeding 7 characters:

- a) the registration marking of the aircraft (e.g. EIAKO, 4XBCD, N2567GA), when:
 - 1) in radiotelephony the call sign to be used by the aircraft will consist of this identification

alone (e.g. OOTEK), or preceded by the ICAO telephony designator for the aircraft operating agency (e.g. SABENA OOTEK);

2) the aircraft is not equipped with radio;

OR b) the ICAO designator for the aircraft operating agency followed by the flight identification (e.g. KLM511, NGA213, JTR25) when in radiotelephony the call sign to be used by the aircraft will consist of the ICAO telephony designator for the operating agency followed by the flight identification (e.g. KLM511, NIGERIA 213, HERBIE 25).

Note.— Provisions for the use of radiotelephony call signs are contained in Annex 10, Volume II, Chapter 5. ICAO designators and telephony designators for aircraft operating agencies are contained in Doc 8585 — Designators for Aircraft Operating Agencies, Aeronautical Authorities and Services.

ITEM 8: FLIGHT RULES AND TYPE OF FLIGHT (ONE OR TWO CHARACTERS)

Flight rules

INSERT one of the following letters to denote the category of flight rules with which the pilot intends to comply:

- I if IFR
- V if VFR
- Y if IFR first) and specify in Item 15 the point or
- Z if VFR first) points where a change of flight rules is planned.

Type of flight

INSERT one of the following letters to denote the type of flight when so required by the appropriate ATS authority:

- S if scheduled air service
- N if non-scheduled air transport operation

- G if general aviation
- M if military
- X if other than any of the defined categories above.

ITEM 9: NUMBER AND TYPE OF AIRCRAFT AND WAKE TURBULENCE CATEGORY

Number of aircraft (1 or 2 characters)

INSERT the number of aircraft, if more than one.

Type of aircraft (2 to 4 characters)

INSERT the appropriate designator as specified in ICAO Doc 8643, *Aircraft Type Designators*,

OR, if no such designator has been assigned, or in case of formation flights comprising more than one type,

INSERT ZZZZ, and *SPECIFY* in Item 18, the (numbers and) type(s) of aircraft preceded by TYP/ .

Wake turbulence category (1 character)

INSERT an oblique stroke followed by one of the following letters to indicate the wake turbulence category of the aircraft:

- H — HEAVY, to indicate an aircraft type with a maximum certificated take-off mass of 136 000 kg or more;
- M — MEDIUM, to indicate an aircraft type with a maximum certificated take-off mass of less than 136 000 kg but more than 7 000 kg;
- L — LIGHT, to indicate an aircraft type with a maximum certificated take-off mass of 7 000 kg or less.

ITEM 10: EQUIPMENT

Radio communication, navigation and approach aid equipment

INSERT one letter as follows:

N if no COM/NAV/approach aid equipment for the route to be flown is carried, or the equipment is unserviceable,

OR S if standard COM/NAV/approach aid equipment for the route to be flown is carried and serviceable (*see Note 1*),

AND/OR

INSERT one or more of the following letters to indicate the COM/NAV/approach aid equipment available and serviceable:

- | | |
|--|---|
| A (Not allocated) | M Omega |
| B (Not allocated) | O VOR |
| C LORAN C | P (Not allocated) |
| D DME | Q (Not allocated) |
| E (Not allocated) | R RNP type certification (<i>see Note 5</i>) |
| F ADF | T TACAN |
| G (GNSS) | U UHF RTF |
| H HF RTF | V VHF RTF |
| I Inertial Navigation | W |
| J (Data Link) (<i>see Note 3</i>) | X } when prescribed |
| K (MLS) | Y } by ATS |
| L ILS | Z } Other equipment carried (<i>see Note 2</i>). |

Note 1.— Standard equipment is considered to be VHF RTF, ADF, VOR and ILS, unless another combination is prescribed by the appropriate ATS authority.

Note 2.— If the letter Z is used, specify in Item 18 the other equipment carried, preceded by COM/ and/or NAV/ , as appropriate.

Note 3.— If the letter J is used, specify in Item 18 the equipment carried, preceded by DAT/ followed by one or more letters as appropriate.

Note 4.— Information on navigation capability is provided to ATC for clearance and routing purposes.

Note 5.— Inclusion of letter R indicates that an aircraft meets the RNP type prescribed for the route segment(s), route(s) and/or area concerned.

| |
|------------------------|
| Surveillance equipment |
|------------------------|

INSERT one or two of the following letters to describe the serviceable surveillance equipment carried:

SSR equipment

- N Nil
- A Transponder — Mode A (4 digits — 4 096 codes)
- C Transponder — Mode A (4 digits — 4 096 codes) and Mode C
- X Transponder — Mode S without both aircraft identification and pressure-altitude transmission
- P Transponder — Mode S, including pressure-altitude transmission, but no aircraft identification transmission
- I Transponder — Mode S, including aircraft identification transmission, but no pressure-altitude transmission
- S Transponder — Mode S, including both pressure-altitude and aircraft identification transmission.

ADS equipment

- D ADS capability

| |
|---|
| ITEM 13: DEPARTURE AERODROME AND TIME (8 CHARACTERS) |
|---|

INSERT the ICAO four-letter location indicator of the departure aerodrome,

OR, if no location indicator has been assigned,

INSERT ZZZZ and *SPECIFY*, in Item 18, the name of the aerodrome preceded by DEP/ ,

OR, if the flight plan is received from an aircraft in flight,

INSERT AFIL, and *SPECIFY*, in Item 18, the ICAO four-letter location indicator of the location of the ATS unit from which supplementary flight plan data can be obtained, preceded by DEP/ .

THEN, WITHOUT A SPACE,

INSERT for a flight plan submitted before departure, the estimated off-block time,

OR, for a flight plan received from an aircraft in flight, the actual or estimated time over the first point of the route to which the flight plan applies.

| |
|-----------------------|
| ITEM 15: ROUTE |
|-----------------------|

INSERT the *first cruising speed* as in (a) and the *first cruising level* as in (b), without a space between them.

THEN, following the arrow, *INSERT* the route description as in (c).

| |
|---|
| (a) Cruising speed (maximum 5 characters) |
|---|

INSERT the *True Air Speed* for the first or the whole cruising portion of the flight, in terms of:

Kilometres per hour, expressed as K followed by 4 figures (e.g. K0830), *or*

Knots, expressed as N followed by 4 figures (e.g. N0485), *or*

Mach number, when so prescribed by the appropriate ATS authority, to the nearest hundredth of unit Mach, expressed as M followed by 3 figures (e.g. M082).

| |
|---|
| (b) Cruising level (maximum 5 characters) |
|---|

INSERT the planned cruising level for the first or the whole portion of the route to be flown, in terms of:

Flight level, expressed as F followed by 3 figures (e.g. F085; F330), *or*

* *Standard Metric Level in tens of metres*, expressed as S followed by 4 figures (e.g. S1130), *or*

* When so prescribed by the appropriate ATS authorities.

Altitude in hundreds of feet, expressed as A followed by 3 figures (e.g. A045; A100), or

Altitude in tens of metres, expressed as M followed by 4 figures (e.g. M0840), or

for uncontrolled VFR flights, the letters VFR.

(c) Route (including changes of speed, level and/or flight rules)

Flights along designated ATS routes

INSERT, if the departure aerodrome is located on or connected to the ATS route, the designator of the first ATS route,

OR, if the departure aerodrome is not on or connected to the ATS route, the letters DCT followed by the point of joining the first ATS route, followed by the designator of the ATS route.

THEN

INSERT each point at which either a change of speed or level, a change of ATS route, and/or a change of flight rules is planned,

Note.— When a transition is planned between a lower and upper ATS route and the routes are oriented in the same direction, the point of transition need not be inserted.

FOLLOWED IN EACH CASE

by the designator of the next ATS route segment, even if the same as the previous one,

OR by DCT, if the flight to the next point will be outside a designated route, unless both points are defined by geographical coordinates.

Flights outside designated ATS routes

INSERT points normally not more than 30 minutes flying time or 370 km (200 NM) apart, including each point at which a change of speed or level, a change of track, or a change of flight rules is planned.

Rules of the Air and Air Traffic Services (PANS-RAC)

OR, when required by appropriate ATS authority(ies),

DEFINE the track of flights operating predominantly in an east-west direction between 70°N and 70°S by reference to significant points formed by the intersections of half or whole degrees of latitude with meridians spaced at intervals of 10 degrees of longitude. For flights operating in areas outside those latitudes the tracks shall be defined by significant points formed by the intersection of parallels of latitude with meridians normally spaced at 20 degrees of longitude. The distance between significant points shall, as far as possible, not exceed one hour's flight time. Additional significant points shall be established as deemed necessary.

For flights operating predominantly in a north-south direction, define tracks by reference to significant points formed by the intersection of whole degrees of longitude with specified parallels of latitude which are spaced at 5 degrees.

INSERT DCT between successive points unless both points are defined by geographical coordinates or by bearing and distance.

USE ONLY the conventions in (1) to (5) below and *SEPARATE* each sub-item by a space.

(1) ATS route (2 to 7 characters)

The coded designator assigned to the route or route segment including, where appropriate, the coded designator assigned to the standard departure or arrival route (e.g. BCN1, B1, R14, UB10, KODAP2A).

Note.— Provisions for the application of route designators are contained in Annex 11, Appendix 1, whilst guidance material on the application of an RNP type to a specific route segment(s), route(s) or area is contained in the Manual on Required Navigation Performance (RNP) (Doc 9613).

(2) Significant point (2 to 11 characters)

The coded designator (2 to 5 characters) assigned to the point (e.g. LN, MAY, HADDY), or,

if no coded designator has been assigned, one of the following ways:

— *Degrees only* (7 characters):

2 figures describing latitude in degrees, followed by “N” (North) or “S” (South), followed by 3 figures describing longitude in degrees, followed by “E” (East) or “W” (West). Make up the correct number of figures, where necessary, by insertion of zeros, e.g. 46N078W.

— *Degrees and minutes* (11 characters):

4 figures describing latitude in degrees and tens and units of minutes followed by “N” (North) or “S” (South), followed by 5 figures describing longitude in degrees and tens and units of minutes, followed by “E” (East) or “W” (West). Make up the correct number of figures, where necessary, by insertion of zeros, e.g. 4620N07805W.

— *Bearing and distance from a navigation aid:*

The identification of the navigation aid (normally a VOR), in the form of 2 or 3 characters, THEN the bearing from the aid in the form of 3 figures giving degrees magnetic, THEN the distance from the aid in the form of 3 figures expressing nautical miles. Make up the correct number of figures, where necessary, by insertion of zeros — e.g. a point 180° magnetic at a distance of 40 nautical miles from VOR “DUB” should be expressed as DUB180040.

(3)

Change of speed or level
(maximum 21 characters)

The point at which a change of speed (5% TAS or 0.01 Mach or more) or a change of level is planned, expressed exactly as in (2) above, followed by an *oblique stroke and both the cruising speed and the cruising level*, expressed exactly as in (a) and (b) above, without a space between them, *even when only one of these quantities will be changed.*

Examples: LN/N0284A045
MAY/N0305F180
HADDY/N0420F330
4602N07805W/N0500F350
46N078W/M082F330
DUB180040/N0350M0840

(4)

Change of flight rules
(maximum 3 characters)

The point at which the change of flight rules is planned, expressed exactly as in (2) or (3) above as appropriate, *followed by a space and one of the following:*

VFR if from IFR to VFR
IFR if from VFR to IFR

Examples: LN VFR
LN/N0284A050 IFR

(5)

Cruise climb (maximum 28 characters)

The letter C followed by an *oblique stroke; THEN the point at which cruise climb is planned to start*, expressed exactly as in (2) above, *followed by an oblique stroke; THEN the speed to be maintained during cruise climb*, expressed exactly as in (a) above, followed by *the two levels defining the layer to be occupied during cruise climb*, each level expressed exactly as in (b) above, *or the level above which cruise climb is planned followed by the letters PLUS*, without a space between them.

Examples: C/48N050W/M082F290F350
C/48N050W/M082F290PLUS
C/52N050W/M220F580F620.

**ITEM 16: DESTINATION AERODROME AND
TOTAL ESTIMATED ELAPSED TIME,
ALTERNATE AERODROME(S)**

Destination aerodrome and total
estimated elapsed time (8 characters)

INSERT the ICAO four-letter location indicator of the destination aerodrome followed, without a space, by the total estimated elapsed time,

OR, if no location indicator has been assigned,

INSERT ZZZZ followed, without a space, by the total estimated elapsed time, and *SPECIFY* in Item 18 the name of the aerodrome, preceded by DEST/ .

Note.— For a flight plan received from an aircraft in flight, the total estimated elapsed time is the estimated time from the first point of the route to which the flight plan applies.

Alternate aerodrome(s) (4 characters)

INSERT the ICAO four-letter location indicator(s) of not more than two alternate aerodromes, separated by a space,

OR, if no location indicator has been assigned to the alternate aerodrome,

INSERT ZZZZ and *SPECIFY* in Item 18 the name of the aerodrome, preceded by ALTN/ .

ITEM 18: OTHER INFORMATION

INSERT 0 (zero) if no other information,

OR, any other necessary information in the preferred sequence shown hereunder, in the form of the appropriate indicator followed by an oblique stroke and the information to be recorded:

EET/ Significant points or FIR boundary designators and accumulated estimated elapsed times to such points or FIR boundaries, when so prescribed on the basis of regional air navigation agreements, or by the appropriate ATS authority.

Examples: EET/CAP0745 XYZ0830
EET/EINN0204

RIF/ The route details to the revised destination aerodrome, followed by the ICAO four-letter location indicator of the aerodrome. The revised route is subject to reclearance in flight.

Examples: RIF/DTA HEC KLAX
RIF/ESP G94 CLA APPH
RIF/LEMD

REG/ The registration markings of the aircraft, if different from the aircraft identification in Item 7.

Rules of the Air and Air Traffic Services (PANS-RAC)

SEL/ SELCAL Code, if so prescribed by the appropriate ATS authority.

OPR/ Name of the operator, if not obvious from the aircraft identification in Item 7.

STS/ Reason for special handling by ATS, e.g. hospital aircraft, one engine inoperative, e.g. STS/HOSP, STS/ONE ENG INOP.

TYP/ Type(s) of aircraft, preceded if necessary by number(s) of aircraft, if ZZZZ is inserted in Item 9.

PER/ Aircraft performance data, if so prescribed by the appropriate ATS authority.

COM/ Significant data related to communication equipment as required by the appropriate ATS authority, e.g. COM/UHF only.

DAT/ Significant data related to data link capability, using one or more of the letters S, H, V and M, e.g. DAT/S for satellite data link, DAT/H for HF data link, DAT/V for VHF data link, DAT/M for SSR Mode S data link.

NAV/ Significant data related to navigation equipment as required by the appropriate ATS authority.

DEP/ Name of departure aerodrome, if ZZZZ is inserted in Item 13, or the ICAO four-letter location indicator of the location of the ATS unit from which supplementary flight plan data can be obtained, if AFIL is inserted in Item 13.

DEST/ Name of destination aerodrome, if ZZZZ is inserted in Item 16.

ALTN/ Name of destination alternate aerodrome(s), if ZZZZ is inserted in Item 16.

RALT/ Name of en-route alternate aerodrome(s).

CODE/ Aircraft address (expressed in the form of an alphanumerical code of six hexadecimal characters) when required by the appropriate ATS authority. Example: "F00001" is the lowest aircraft address contained in the specific block administered by ICAO.

RMK/ Any other plain language remarks when required by the appropriate ATS authority or deemed necessary.

ITEM 19: SUPPLEMENTARY INFORMATION

Endurance

After E/ *INSERT* a 4-figure group giving the fuel endurance in hours and minutes.

Persons on board

After P/ *INSERT* the total number of persons (passengers and crew) on board, when required by the appropriate ATS authority. *INSERT* TBN (to be notified) if the total number of persons is not known at the time of filing.

Emergency and survival equipment

R/ (RADIO) *CROSS OUT* U if UHF on frequency 243.0 MHz is not available. *CROSS OUT* V if VHF on frequency 121.5 MHz is not available. *CROSS OUT* E if emergency locator transmitter (ELT) is not available.

S/ (SURVIVAL EQUIPMENT) *CROSS OUT* all indicators if survival equipment is not carried. *CROSS OUT* P if polar survival equipment is not carried. *CROSS OUT* D if desert survival equipment is not carried. *CROSS OUT* M if maritime survival equipment is not carried. *CROSS OUT* J if jungle survival equipment is not carried.

J/ (JACKETS) *CROSS OUT* all indicators if life jackets are not carried. *CROSS OUT* L if life jackets are not equipped with lights. *CROSS OUT* F if life jackets are not equipped with

fluorescein. *CROSS OUT* U or V or both as in R/ above to indicate radio capability of jackets, if any.

D/ (DINGHIES) (NUMBER) *CROSS OUT* indicators D and C if no dinghies are carried, or *INSERT* number of dinghies carried; and

(CAPACITY) *INSERT* total capacity, in persons, of all dinghies carried; and

(COVER) *CROSS OUT* indicator C if dinghies are not covered; and

(COLOUR) *INSERT* colour of dinghies if carried.

A/ (AIRCRAFT COLOUR AND MARKINGS) *INSERT* colour of aircraft and significant markings.

N/ (REMARKS) *CROSS OUT* indicator N if no remarks, or *INDICATE* any other survival equipment carried and any other remarks regarding survival equipment.

C/ (PILOT) *INSERT* name of pilot-in-command.

2.3 Filed by

INSERT the name of the unit, agency or person filing the flight plan.

2.4 Acceptance of the flight plan

Indicate acceptance of the flight plan in the manner prescribed by the appropriate ATS authority.

2.5 Instructions for insertion of COM data

Items be completed

COMPLETE the top two shaded lines of the form, and *COMPLETE* the third shaded line only when necessary, in accordance with the provisions in PANS-RAC, Part IX, 2.1.2, unless ATS prescribes otherwise.

3. Instructions for the transmission of a filed flight plan (FPL) message

Correction of obvious errors

Unless otherwise prescribed, *CORRECT* obvious format errors and/or omissions (i.e. oblique strokes) to ensure adherence as specified in Section 2.

Items to be transmitted

TRANSMIT items as indicated hereunder, unless otherwise prescribed:

- a) the items in the shaded lines, above Item 3;
- b) commencing with <<≡ (FPL of Item 3:

all symbols and data in the unshaded boxes down to the)<<≡ at the end of Item 18,

additional alignment functions as necessary to prevent the inclusion of more than 69 characters in any line of Items 15 or 18. The alignment function is to be inserted only in lieu of a space so as not to break up a group of data,

letter shifts and figure shifts (not preprinted on the form) as necessary;

- c) the AFTN Ending, as described below:

End-of-Text Signal

- a) one LETTER SHIFT
- b) two CARRIAGE RETURNS, one LINE FEED

Page-feed Sequence

Seven LINE FEEDS

End-of-Message Signal

Four of the letter N.

4. Instructions for the transmission of a supplementary flight plan (SPL) message

Items to be transmitted

Transmit items as indicated hereunder, unless otherwise prescribed:

- a) AFTN Priority Indicator, Addressee Indicators <<≡, Filing Time, Originator Indicator <<≡ and, if necessary, specific identification of addressees and/or originator;
- b) commencing with <<≡ (SPL:

all symbols and data in the unshaded areas of boxes 7, 16 and 18, except that the ‘)’ at the end of box 18 is *not* to be transmitted, and then the symbols in the unshaded area of box 19 down to and including the)<<≡ of box 19,

additional alignment functions as necessary to prevent the inclusion of more than 69 characters in any line of Items 18 and 19. The alignment function is to be inserted only in lieu of a space, so as not to break up a group of data,

letter shifts and figure shifts (not preprinted on the form) as necessary;

- c) the AFTN Ending, as described below:

End-of-Text Signal

- a) one LETTER SHIFT
- b) two CARRIAGE RETURNS, one LINE FEED

Page-feed Sequence

Seven LINE FEEDS

End-of-Message Signal

Four of the letter N.

5. Example of a completed flight plan form

| FLIGHT PLAN PLAN DE VOL | | | |
|--|---|--|--|
| PRIORITY Priorité <<≡ FF → | ADDRESSEE(S) Destinataire(s) EHAA ZQZX EBURZQZX EDDYZQZX LFFFZQZX LFRAZQZX LFBZQZX LECMZQZX LPPCZQZX | | |
| FILING TIME Heure de dépôt L 9 0 8 3 6 → | ORIGINATOR Expéditeur EHAMZPZX <<≡ | | |
| SPECIFIC IDENTIFICATION OF ADDRESSEE(S) AND/OR ORIGINATOR Identification précise du(des) destinataire(s) et/ou de l'expéditeur | | | |
| 3 MESSAGE TYPE Type de message <<≡ (FPL | 7 AIRCRAFT IDENTIFICATION Identification de l'aéronef - AC F 4 0 2 | 8 FLIGHT RULES Règles de vol - I | TYPE OF FLIGHT Type de vol N <<≡ |
| 9 NUMBER Nombre - | TYPE OF AIRCRAFT Type d'aéronef EA 3 0 | WAKE TURBULENCE CAT. Cat. de turbulence de sillage / H | 10 EQUIPMENT Équipement - S / C <<≡ |
| 13 DEPARTURE AERODROME Aérodrome de départ - EHAM | TIME Heure 0 9 4 0 <<≡ | | |
| 15 CRUISING SPEED Vitesse croisière - K 0 8 3 0 | LEVEL Niveau F 2 9 0 | ROUTE Route LEK 2 B LEK UA 6 XMM/MO 7 8 F 3 3 0 UA 6 PON URION CHW UA 5 NTS DCT 4 6 1 1 N 0 0 4 1 2 W DCT STG UA 5 FTM FATIMIA | |
| <<≡ | | | |
| 16 DESTINATION AERODROME Aérodrome de destination - LPPT | TOTAL EET Durée totale estimée HR. MIN 0 2 3 0 | ALTN AERODROME Aérodrome de dégagement - LPPR | 2ND. ALTN AERODROME 2ème aérodrome de dégagement - <<≡ |
| 18 OTHER INFORMATION Renseignements divers - REG / FBVGA SEL / EJFL EET / LPPC 0 1 5 8 | | | |
|) <<≡ | | | |
| SUPPLEMENTARY INFORMATION (NOT TO BE TRANSMITTED IN FPL MESSAGES) Renseignements complémentaires (À NE PAS TRANSMETTRE DANS LES MESSAGES DE PLAN DE VOL DÉPOSÉ) | | | |
| 19 ENDURANCE Autonomie HR. MIN - E / 0 3 4 5 | PERSONS ON BOARD Personnes à bord → P / 3 0 0 | EMERGENCY RADIO Radio de secours → R / UHF [U] VHF [V] ELT [E] | |
| SURVIVAL EQUIPMENT/Équipement de survie → S / POLAR [X] DESERT [X] MARITIME [M] JUNGLE [X] | | | |
| JACKETS/Gilets de sauvetage → J / LIGHT [L] FLUORES [F] UHF [X] VHF [X] | | | |
| DINGHIES/Canots → D / 1 1 | CAPACITY Capacité → 3 3 0 | COVER Couverture → C | COLOUR Couleur → YELLOW <<≡ |
| AIRCRAFT COLOUR AND MARKINGS Couleur et marques de l'aéronef A / WHITE | | | |
| REMARKS Remarques → [X] <<≡ | | | |
| PILOT-IN-COMMAND Pilotte commandant de bord C / DENKE <<≡ | | | |
| FILED BY/Déposé par AIR CHARTER INT. | | SPACE RESERVED FOR ADDITIONAL REQUIREMENTS Espace réservé à des fins supplémentaires | |

6. ICAO model repetitive flight plan (RPL) listing form

REPETITIVE FLIGHT PLAN LISTING

| A OPERATOR | | B ADDRESSEE(S) | | C DEPARTURE AERODROME(S) | | D | E | F | | | | | | |
|------------|---|----------------|------------|--------------------------|---------------------------------|--------------------------|-------------------------------------|---|---|--------------------|----------------------|-------|---|---------|
| | | | | | | DATE ----- yyymmdd | SERIAL NO. ----- | PAGE OF -- / -- | | | | | | |
| H | I | J | K | | L | M | N | O | P | Q | | | | |
| + | - | yyymmdd | VALID FROM | VALID UNTIL yyymmdd | 1 2 3 4 5 6 7 | DAYS OF OPERATION | AIRCRAFT IDENTIFICATION (Item 7) | TYPE OF AIRCRAFT AND WAKE TURBULENCE CATEGORY (Item 9) | DEPARTURE AERODROME AND TIME (Item 13) | ROUTE (Item 15) | CRUISING SPEED LEVEL | ROUTE | DESTINATION AERODROME AND TOTAL ESTIMATED ELAPSED TIME (Item 16) | REMARKS |
| | | | | | | | | | | | | | | |
| | | | | | | | | | | | | | | |
| | | | | | | | | | | | | | | |
| | | | | | | | | | | | | | | |
| | | | | | | | | | | | | | | |
| | | | | | | | | | | | | | | |
| | | | | | | | | | | | | | | |
| | | | | | | | | | | | | | | |
| | | | | | | | | | | | | | | |
| | | | | | | | | | | | | | | |
| | | | | | | | | | | | | | | |
| | | | | | | | | | | | | | | |
| | | | | | | | | | | | | | | |
| | | | | | | | | | | | | | | |

7. Instructions for the completion of the repetitive flight plan (RPL) listing form

7.1 General

List only flight plans that will operate in accordance with IFR. (Flight rules I in FPL format).

It is assumed that all aircraft are operating as scheduled flights (Type of flight S in FPL format), otherwise *notify* in Q (Remarks).

It is assumed that all aircraft operating on RPLs are equipped with 4 096-code transponders with Modes A and C. Otherwise, *notify* in Q (Remarks).

List flight plans in *alphabetical order of the location indicator of the departure aerodrome*.

List flight plans for each departure aerodrome in chronological order of estimated off-block times.

Adhere closely to the data conventions as indicated for the Flight Plan Form (Appendix 3, 1.6) unless otherwise specifically indicated in 7.4.

Insert all clock times in 4 figures UTC.

Insert all estimated elapsed times in 4 figures (hours and minutes).

Insert data on a separate line for each segment of operations with one or more stops; i.e. from any departure aerodrome to the next destination aerodrome even though call sign or flight number is the same for multiple segments.

Clearly identify additions and deletions in accordance with Item H at 7.4. Subsequent listings shall list the corrected and added data, and deleted flight plans shall be omitted.

Number pages by indicating number of page and total number of pages in submission.

Utilize more than one line for any RPL where the space provided for items O and Q on one line is not sufficient.

7.2 A flight shall be cancelled as follows:

- a) indicate a minus sign in Item H followed by all other items of the cancelled flight;

- b) insert a subsequent entry denoted by a plus sign in Item H and the date of the last flight in Item J, with all other items of the cancelled flight unchanged.

7.3 Modification to a flight shall be made as follows:

- a) carry out the cancellation as indicated in 7.2; and
- b) insert a third entry giving the new flight plan(s) with the appropriate items modified as necessary, including the new validity dates in Items I and J.

Note.— All entries related to the same flight will be inserted in succession in the order specified above.

7.4 Instructions for insertion of RPL data

Complete Items A to Q as indicated hereunder.

ITEM A: OPERATOR

INSERT name of operator.

ITEM B: ADDRESSEE(S)

INSERT name of agency(ies) designated by States to administer RPLs for FIRs or areas of responsibility concerned with the route of flight.

ITEM C: DEPARTURE AERODROME(S)

INSERT location indicator(s) of departure aerodrome(s).

ITEM D: DATE

INSERT on each page of submission the date (year, month, day) in a 6-figure group that the listing was submitted.

ITEM E: SERIAL NO.

INSERT serial number of submission (2 numerics) indicating last two digits of year, a dash, and the sequential no. of the submission for the year indicated (start with numeral 1 each new year).

ITEM F: PAGE OF

INSERT page number and total number of pages submitted.

ITEM G: SUPPLEMENTARY DATA AT

INSERT name of contact where information normally provided under Item 19 of the FPL is kept readily available and can be supplied without delay.

ITEM H: ENTRY TYPE

INSERT a minus sign (-) for each flight plan that is to be deleted from the listing.

INSERT a plus sign (+) for each initial listing and, in the case of subsequent submissions, for each flight plan not listed in the previous submission.

Note.— No information is required under this item for any flight plan which is unchanged from the previous submission.

ITEM I: VALID FROM

INSERT first date (year, month, day) upon which the flight is scheduled to operate.

ITEM J: VALID UNTIL

INSERT last date (year, month, day) upon which the flight is scheduled to operate as listed, or

UFN if the duration is unknown.

ITEM K: DAYS OF OPERATION

INSERT number corresponding to the day of the week in the appropriate column;
Monday = 1 through Sunday = 7.

INSERT 0 for each day of non-operation in the appropriate column.

ITEM L: AIRCRAFT IDENTIFICATION

(Item 7 of the ICAO flight plan)

INSERT aircraft identification to be used for the flight.

ITEM M: TYPE OF AIRCRAFT AND WAKE TURBULENCE CATEGORY

(Item 9 of the ICAO flight plan)

INSERT appropriate ICAO designator as specified in ICAO Doc 8643 — *Aircraft Type Designators*.

INSERT H, M or L indicator as appropriate:

H — HEAVY to indicate an aircraft type with a maximum certificated take-off mass of 136 000 kg or more,

M — MEDIUM to indicate an aircraft type with a maximum certificated take-off mass of less than 136 000 kg but more than 7 000 kg,

L — LIGHT to indicate an aircraft type with a maximum certificated take-off mass of 7 000 kg or less.

ITEM N: DEPARTURE AERODROME AND TIME

(Item 13 of the ICAO flight plan)

INSERT location indicator of the departure aerodrome.

INSERT the off-block time, i.e. the estimated time that the aircraft will commence movement associated with departure.

(c) Route

INSERT the entire route in accordance with Item 15 (c) of the ICAO flight plan.

ITEM O: ROUTE

(Item 15 of the ICAO flight plan)

ITEM P: DESTINATION AERODROME AND TOTAL ESTIMATED ELAPSED TIME

(Item 16 of the ICAO flight plan)

(a) Cruising speed

INSERT the true airspeed for the first or whole cruising portion of the flight in accordance with Item 15 (a) of the ICAO flight plan.

INSERT location indicator of the destination aerodrome.

INSERT the total estimated elapsed time.

(b) Cruising level

INSERT the planned cruising level for the first or whole portion of the route in accordance with Item 15 (b) of the ICAO flight plan.

ITEM Q: REMARKS

INSERT items of information as required by the appropriate ATS authority, items normally notified in Item 18 of the ICAO flight plan and any other information pertinent to the flight of concern to ATS.

8. Example of a completed repetitive flight plan (RPL) listing form

REPETITIVE FLIGHT PLAN LISTING

| A OPERATOR | | B ADDRESSEE(S) | | | | | | | C DEPARTURE AERODROME(S) | | | D | E | F | | | | | | | | |
|-----------------|-----------------------|---|-------------------|---|---|---|---|---|--------------------------|-------------------------------------|---|---|---------------------|------------------|--------------------|---|-----------------------|------|------|----------------|--|--|
| BRITISH AIRWAYS | | UK STORED FLIGHT PLAN OFFICE EGTZBZX Chef de la Subdivision informatique 9 rue de Champagne 91205 Athismons France | | | | | | | EGLL | | | DATE 800305 yyymmdd | SERIAL NO. 80-12 | PAGE OF 3 / 3 | | | | | | | | |
| H | I | J | K | | | | | | | L | M | N | O | P | Q | | | | | | | |
| | | | DAYS OF OPERATION | | | | | | | | | | | | | | | | | | | |
| | VALID FROM yyymmdd | VALID UNTIL yyymmdd | 1 | 2 | 3 | 4 | 5 | 6 | 7 | AIRCRAFT IDENTIFICATION (Item 7) | TYPE OF AIRCRAFT AND WAKE TURBULENCE CATEGORY (Item 9) | DEPARTURE AERODROME AND TIME (Item 13) | CRUISING SPEED | LEVEL | ROUTE (Item 15) | DESTINATION AERODROME AND TOTAL ESTIMATED ELAPSED TIME (Item 16) | REMARKS | | | | | |
| + | 800401 | 811031 | 1 | 2 | 3 | 4 | 5 | 6 | 7 | BAW004 | HS21 | M | EGLL | 0700 | N0440 | F210 | A1E UA1E DPE UA16 MAN | LFPG | 0045 | | | |
| + | 800401 | 800731 | 1 | 2 | 3 | 4 | 5 | 6 | 7 | BAW032 | HS21 | M | EGLL | 1800 | N0440 | F210 | A1E UA1E DPE UA16 MAN | LFPG | 0045 | | | |
| + | 800801 | 811031 | 1 | 0 | 3 | 0 | 5 | 0 | 7 | BAW032 | HS21 | M | EGLL | 1800 | N0440 | F210 | A1E UA1E DPE UA16 MAN | LFPG | 0045 | | | |
| + | 800601 | 800930 | 0 | 0 | 0 | 0 | 0 | 0 | 7 | BAW082 | HS21 | M | EGLL | 1805 | N0450 | F270 | A1S UA1S RBT UA3 MTL | | | | | |
| | | | | | | | | | | | | | | | | | UA3W STP DCT GL | LFMN | 0130 | | | |
| - | 800103 | 800930 | 0 | 0 | 0 | 0 | 0 | 6 | 7 | BAW092 | B737 | M | EGLL | 1810 | N0430 | F190 | A1E UA1E DPE UA16 MAN | LFPG | 0400 | CHARTERED ACFT | | |
| + | 800103 | 800315 | 0 | 0 | 0 | 0 | 0 | 6 | 7 | BAW092 | B737 | M | EGLL | 1810 | N0430 | F190 | A1E UA1E DPE UA16 MAN | LFPG | 0400 | CHARTERED ACFT | | |
| | | | | | | | | | | | | | | | | | | | | | | |
| | | | | | | | | | | | | | | | | | | | | | | |
| | | | | | | | | | | | | | | | | | | | | | | |
| | | | | | | | | | | | | | | | | | | | | | | |
| | | | | | | | | | | | | | | | | | | | | | | |
| | | | | | | | | | | | | | | | | | | | | | | |
| | | | | | | | | | | | | | | | | | | | | | | |
| | | | | | | | | | | | | | | | | | | | | | | |
| | | | | | | | | | | | | | | | | | | | | | | |
| | | | | | | | | | | | | | | | | | | | | | | |
| | | | | | | | | | | | | | | | | | | | | | | |
| | | | | | | | | | | | | | | | | | | | | | | |
| | | | | | | | | | | | | | | | | | | | | | | |

APPENDIX 3. AIR TRAFFIC SERVICES MESSAGES

1. Message contents, formats and data conventions
2. Examples of ATS messages

1. Message contents, formats and data conventions

Note.— To facilitate description of the content and format of air traffic services messages, both for interchange between units without automatic data processing equipment and for interchange between air traffic control computers, the elements of data to be included in the message are grouped into “fields”. Each field contains a single element or a group of related elements.

1.1 The standard types of message

1.1.1 The standard types of message established for the interchange of ATS data, together with the associated Message Type Designators, are as follows:

| <i>Message category</i> | <i>Message type</i> | <i>Message type designator</i> |
|---|-----------------------------------|--------------------------------|
| Emergency | Alerting | ALR |
| | Radio communication failure | RCF |
| Filed flight plan and associated update | Filed flight plan | FPL |
| | Modification | CHG |
| | Cancellation | CNL |
| | Delay | DLA |
| | Departure | DEP |
| | Arrival | ARR |
| Co-ordination | Current flight plan | CPL |
| | Estimate | EST |
| | Co-ordination | CDN |
| | Acceptance | ACP |
| | Logical acknowledgement | LAM |
| Supplementary | Request flight plan | RQP |
| | Request supplementary flight plan | RQS |
| | Supplementary flight plan | SPL |

1.2 The standard types of field

1.2.1 The standard fields of data permitted in ATS messages are as shown in the following table. The numbers in column 1 correspond with those in the reference table on page A3-30.

| <i>Field type</i> | <i>Data</i> |
|-------------------|--|
| 3 | Message type, number and reference data |
| 5 | Description of emergency |
| 7 | Aircraft identification and SSR Mode and Code |
| 8 | Flight rules and type of flight |
| 9 | Number and type of aircraft and wake turbulence category |
| 10 | Equipment |
| 13 | Departure aerodrome and time |
| 14 | Estimate data |
| 15 | Route |
| 16 | Destination aerodrome and total estimated elapsed time, alternate aerodrome(s) |
| 17 | Arrival aerodrome and time |
| 18 | Other information |
| 19 | Supplementary information |
| 20 | Alerting search and rescue information |
| 21 | Radio failure information |
| 22 | Amendment |

1.3 Composition of the standard types of message

1.3.1 The composition of each standard type of message, expressed as a standardized sequence of fields of data, shall be as prescribed in the reference table on page A3-30. Each message shall contain all the fields prescribed.

1.4 Composition of the standard types of field

1.4.1 The composition of each standard type of field, expressed as a standardized sequence of elements of data, or in some cases as a simple element, shall be as prescribed in the field tables on pages A3-5 to A3-29.

Note.— Each type of field contains at least one mandatory element and, except in Field Type 9, this is the first or only element in the field. The rules for the inclusion or omission of conditional elements are indicated in the field tables.

1.5 Structuring and punctuation

1.5.1 The beginning of the ATS data shall be indicated on page copy by an Open Bracket ‘(’, which constitutes the

Start-of-ATS-Data Signal. This signal shall be used only as the printed character immediately preceding the Message Type Designator.

Note.— In teletypewriter operation using International Telegraph Alphabet No. 2, the open bracket is transmitted as the Figures Case of Signal No. 11. On some teletypewriter machines, this will print as a symbol other than ‘(’, but this variation will be local and of no consequence. Where higher level codes are employed, the character printing as ‘(’ is used.

1.5.2 The beginning of each field, other than the first, shall be indicated by a single hyphen ‘-’, which constitutes the Start-of-Field Signal. This signal shall be used only as the printed character preceding the first element of ATS data in each field.

Note.— In teletypewriter operation using International Telegraph Alphabet No. 2, the single hyphen is transmitted as the Figures Case of Signal No. 1. On some teletypewriter machines, this will print as a symbol other than ‘-’, but this variation will be local and of no consequence. Where higher level codes are employed, the character printing as ‘-’ is used.

1.5.3 Elements within a field shall be separated by an oblique stroke ‘/’ (see Note 1), or a space (sp.) (see Note 2) only where so prescribed in the field tables on pages A3-5 to A3-29.

Note 1.— In teletypewriter operation using International Telegraph Alphabet No. 2, the oblique stroke is transmitted as the Figures Case of Signal No. 24. On some teletypewriter machines, this will print as a symbol other than ‘/’, but this variation will be local and of no consequence. Where higher level codes are employed, the character printing as ‘/’ is used.

Note 2.— In teletypewriter operation using International Telegraph Alphabet No. 2, the space is transmitted as Signal No. 31. Where higher level codes are employed, the character which causes a space on page copy is to be used.

1.5.4 The end of the ATS data shall be indicated by a close bracket ‘)’, which constitutes the End-of-ATS-Data Signal. This signal shall be used only as the printed character immediately following the last field in the message.

Note.— In teletypewriter operation using International Telegraph Alphabet No. 2, the close bracket is transmitted as Signal No. 12. On some teletypewriter machines, this will

print as a symbol other than ‘)’, but this variation will be local and of no consequence. Where higher level codes are employed, the character printing as ‘)’ is to be used.

1.5.5 When the standard ATS messages are prepared in teletypewriter form, an Alignment Function (two Carriage Returns followed by one Line Feed) shall be inserted:

- a) prior to each of the fields so annotated in the reference table on page A3-30;
- b) in Fields Type 5 (Description of Emergency), 15 (Route), 18 (Other Information), 19 (Supplementary Information), 20 (Alerting Search and Rescue Information), 21 (Radio Failure Information) and 22 (Amendment), whenever it is necessary to begin a new line on page copy (see Note). In such cases, the Alignment Function shall be inserted between two data elements and shall not divide an element.

Note.— Annex 10 prescribes that a line of teletypewriter copy shall not contain more than 69 characters.

1.6 Data conventions

1.6.1 Most of the conventions to be used in the expression of ATS data in the messages are prescribed in the field tables on pages A3-5 to A3-29, but the conventions for the expression of level, position and route data are given below to simplify the field tables.

1.6.2 The expression of level data

1.6.2.1 Four alternative conventions are available for the expression of level data:

- a) “F” followed by 3 decimal numerics: indicates a Flight Level Number, i.e. Flight Level 330 is expressed as “F330”;
- b) “S” followed by 4 decimal numerics: indicates Standard Metric Level in tens of metres, i.e. Standard Metric Level 11 300 metres (Flight Level 370) is expressed as “S1130”;
- c) “A” followed by 3 decimal numerics: indicates altitude in hundreds of feet, i.e. an altitude of 4 500 feet is expressed as “A045”;
- d) “M” followed by 4 decimal numerics: indicates altitude in tens of metres, i.e. an altitude of 8 400 metres is expressed as “M0840”.

1.6.3 The expression of position or route

1.6.3.1 The following alternative data conventions shall be used for the expression of position or route:

- a) from 2 to 7 characters, being the coded designator assigned to an ATS route to be flown;
- b) from 2 to 5 characters, being the coded designator assigned to an en-route point;
- c) 4 numerics describing latitude in degrees and tens and units of minutes, followed by "N" (meaning "North") or "S" (South), followed by 5 numerics describing longitude in degrees and tens and units of minutes, followed by "E" (East) or "W" (West). The correct number of numerics is to be made up, where necessary, by the insertion of zeros, e.g. "4620N07805W";
- d) 2 numerics describing latitude in degrees, followed by "N" (North) or "S" (South), followed by 3 numerics describing longitude in degrees, followed by "E" (East) or "W" (West). Again, the correct number of numerics is to be made up, where necessary, by the insertion of zeros, e.g. "46N078W";
- e) 2 or 3 characters being the coded identification of a navigation aid (normally a VOR), followed by 3 decimal numerics giving the bearing from the point in degrees magnetic followed by 3 decimal numerics giving the distance from the point in nautical miles. The correct number of numerics is to be made up, where necessary, by the insertion of zeros, e.g. a point at 180° magnetic at a distance of 40 nautical miles from VOR "FOJ" would be expressed as "FOJ180040".

1.7 The detail of the fields

1.7.1 The elements of data prescribed or permitted to be included in each type of field, together with a prescription of the conditions or options permitted, are shown on pages A3-5 to A3-29.

1.7.2 A key appears at the right-hand side of each of the field pages; this key permits the sequence of fields in each type of message to be followed.

1.7.3 The first field in each message type is field type 3; on the page describing field type 3 a key indicates the field type number of the next field for each message. On subsequent field pages, the field type number of the previous field is shown to permit back reference also. The Start-of-ATS-Data Signal '(' is used in the key to indicate that there is no previous type of field; the End-of-ATS-Data Signal ')' is used to indicate that there is no next type of field.

1.7.4 On the field pages,

elements with a fixed number of characters are shown diagrammatically as (three characters in this example)



elements of variable length are shown as



1.8 Accuracy in the preparation of ATS messages

1.8.1 Where the standard ATS messages are transmitted by teletypewriter channels in areas where ATC computers are known to be in use, the formats and data conventions prescribed in the field tables on pages A3-5 to A3-29 shall be adhered to rigorously.

Field Type 3 — Message Type, Number and Reference Data

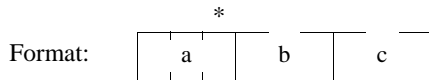

OPEN BRACKET

(a) *Message Type Designator*

3 LETTERS as follows:

| | |
|-----|-----------------------------------|
| ALR | Alerting |
| RCF | Radio communication failure |
| FPL | Filed flight plan |
| CHG | Modification |
| CNL | Cancellation |
| DLA | Delay |
| DEP | Departure |
| ARR | Arrival |
| CPL | Current flight plan |
| EST | Estimate |
| CDN | Co-ordination |
| ACP | Acceptance |
| LAM | Logical acknowledgement |
| RQP | Request flight plan |
| RQS | Request supplementary flight plan |
| SPL | Supplementary flight plan |

* Unless instructed otherwise, this field shall contain only the single element (a). Elements (b) or (b) and (c) are for use when messages are generated by, and/or exchanged between, the computer systems of ATS units.

(b) *Message Number*

| | |
|--------------------|--|
| 1 to 4 LETTER(S) | identifying the sending ATS unit, followed by |
| OBLIQUE STROKE (/) | followed by |
| 1 to 4 LETTER(S) | identifying the receiving ATS unit, followed by |
| 3 DECIMAL NUMERICS | giving the serial number of this message in the sequence of messages transmitted by this unit to the indicated receiving ATS unit. |

FIELD TYPE 3

| <i>Previous type of field or symbol</i> | <i>This type of field is used in</i> | <i>Next type of field or symbol</i> |
|---|--------------------------------------|-------------------------------------|
| (| ALR | 5 |
| (| RCF | 7 |
| (| FPL | 7 |
| (| CHG | 7 |
| (| CNL | 7 |
| (| DLA | 7 |
| (| DEP | 7 |
| (| ARR | 7 |
| (| CPL | 7 |
| (| EST | 7 |
| (| CDN | 7 |
| (| ACP | 7 |
| (| LAM |) |
| (| RQP | 7 |
| (| RQS | 7 |
| (| SPL | 7 |

*Field Type 3 (cont.)***(c) Reference Data**

1 to 4 LETTER(S) followed by OBLIQUE STROKE (/) followed by 1 to 4 LETTER(S) followed by 3 DECIMAL NUMERICS, giving the “message number” contained in element (b) of the operational message which began the sequence of messages of which this message is a part.

Examples: (FPL
(CNL
(CHGA/B234A/B231
(CPLA/B002

Field Type 5 — Description of Emergency

Format: – [a] / [b] / [c]

SINGLE HYPHEN

(a) *Phase of Emergency*

or INCERFA if an uncertainty phase,
 or ALERFA if an alert phase,
 DETRESFA if a distress phase

has been declared in respect of the aircraft concerned.

OBLIQUE STROKE

(b) *Originator of Message*

8 LETTERS, being the 4-letter ICAO location indicator plus the 3-letter designator of the ATS unit originating the message followed by the letter X or, if applicable, the one-letter designator identifying the division of the ATS unit originating the message.

OBLIQUE STROKE

(c) *Nature of Emergency*

SHORT PLAIN LANGUAGE TEXT, as necessary to explain the nature of the emergency, with natural spaces between the words.

Example: –ALERFA/EINNZQZX/REPORT OVERDUE

FIELD TYPE 5

| <i>Previous type of field or symbol</i> | <i>This type of field is used in</i> | <i>Next type of field or symbol</i> |
|---|--------------------------------------|-------------------------------------|
| 3 | ALR | 7 |

Field Type 7 — Aircraft Identification and Mode A Code

FIELD TYPE 7

Format: – (a) Max. 7 characters ^{*} / b c

| Previous type of field or symbol | This type of field is used in | Next type of field or symbol |
|----------------------------------|--|---------------------------------|
| 5 3 | ALR RCF | 8 21 |
| 3 3 3 3 3 3 | FPL CHG CNL DLA DEP ARR | 8 13 13 13 13 13 |
| 3 3 3 3 | CPL EST CDN ACP | 8 13 13 13 |
| 3 3 3 | RQP RQS SPL | 13 13 13 |

SINGLE HYPHEN

(a) *Aircraft Identification*

NOT MORE THAN 7 CHARACTERS, being the aircraft identification shown in the filed flight plan and composed as specified in Appendix 2, Section 2.

* This field may be terminated here in messages relating to flights operating within areas where SSR is not used, or when the SSR Code information is not known or would not be meaningful to the accepting unit.

OBLIQUE STROKE

(b) *SSR Mode*

LETTER A giving the SSR Mode related to (c).

(c) *SSR Code*

4 NUMERICS giving the SSR Code assigned to the aircraft by ATS and transmitted in the Mode given in (b).

Examples: –BAW902
–SAS912/A5100

Field Type 8 — Flight Rules and Type of Flight

| |
|--------------|
| FIELD TYPE 8 |
|--------------|

Format: –

| |
|-------|
| * |
| a b |

| <i>Previous type of field or symbol</i> | <i>This type of field is used in</i> | <i>Next type of field or symbol</i> |
|---|--------------------------------------|-------------------------------------|
| 7 | ALR | 9 |
| 7 | FPL | 9 |
| 7 | CPL | 9 |

SINGLE HYPHEN

(a) *Flight Rules*

1 LETTER as follows:

I if IFR
 V if VFR
 Y if IFR first
 Z if VFR first

Note.— If the letter Y or Z is used, the point or points at which a change of flight rules is planned is to be shown as indicated in Field Type 15.

* This field shall be terminated here unless indication of the type of flight is required by the appropriate ATS authority.

(b) *Type of flight*

1 LETTER as follows:

S if scheduled air transport
 N if non-scheduled air transport
 G if general aviation
 M if military
 X other flights

Examples: –V
 –IS

Field Type 9 — Number and Type of Aircraft and Wake Turbulence Category

| |
|--------------|
| FIELD TYPE 9 |
|--------------|

Format: –

| | | | | |
|--|---|--|---|--|
| | a | | b | |
|--|---|--|---|--|

 /

| | |
|--|---|
| | c |
|--|---|

| Previous type of field or symbol | This type of field is used in | Next type of field or symbol |
|----------------------------------|-------------------------------|------------------------------|
| 8 | ALR | 10 |
| 8 | FPL | 10 |
| 8 | CPL | 10 |

SINGLE HYPHEN

(a) *Number of Aircraft (if more than one)*

Note.— This element is included only in the case of formation flights.

1 OR 2 NUMERICS giving the number of aircraft in the flight.

(b) *Type of Aircraft*

2 to 4 CHARACTERS, being the appropriate designator chosen from ICAO Doc 8643, *Aircraft Type Designators*, or

ZZZZ if no designator has been assigned or if there is more than one type of aircraft in the flight.

Note.— If the letters ZZZZ are used, the type(s) of aircraft is (are) to be shown in the Other Information Field (see Field Type 18).

OBLIQUE STROKE

(c) *Wake Turbulence Category*

1 LETTER to indicate maximum certificated take-off mass of the aircraft:

H — Heavy
 M — Medium
 L — Light

Examples: –DC3/M
 –B707/M
 –2FK27/M
 –ZZZZ/L
 –3ZZZZ/L
 –B747/H

Field Type 10 — Equipment

Format: – a / b

| |
|---------------|
| FIELD TYPE 10 |
|---------------|

| Previous type of field or symbol | This type of field is used in | Next type of field or symbol |
|----------------------------------|-------------------------------|------------------------------|
| 9 | ALR | 13 |
| 9 | FPL | 13 |
| 9 | CPL | 13 |

SINGLE HYPHEN

(a) *Radio Communication, Navigation and Approach Aid Equipment*

1 LETTER as follows:

N no COM/NAV/approach aid equipment for the route to be flown is carried, or the equipment is unserviceable

OR S Standard COM/NAV/approach aid equipment for the route to be flown is carried and serviceable (See Note 1)

AND/OR ONE OR MORE OF THE FOLLOWING LETTERS to indicate the COM/NAV/approach aid equipment serviceable

- | | |
|-------------------------------|---|
| A (Not allocated) | M Omega |
| B (Not allocated) | O VOR |
| C LORAN C | P (Not allocated) |
| D DME | Q (Not allocated) |
| E (Not allocated) | R RNP type certification (see Note 5) |
| F ADF | T TACAN |
| G (GNSS) | U UHF RTF |
| H HF RTF | V VHF RTF |
| I Inertial Navigation | W when |
| J (Data link) (see Note 3) | X } prescribed |
| K (MLS) | Y } by ATS |
| L ILS | Z Other equipment carried (see Note 2) |

Note 1.— Standard equipment is considered to be VHF RTF, ADF, VOR and ILS, unless another combination is prescribed by the appropriate ATS authority.

Note 2.— If the letter Z is used, the equipment carried is to be specified in Item 18, preceded by COM/ and/or NAV/ , as appropriate.

Note 3.— If the letter J is used, specify in Item 18 the equipment carried, preceded by DAT/ followed by one or more letters as appropriate.

Note 4.— Information on navigation capability is provided to ATC for clearance and routing purposes.

Note 5.— Inclusion of letter R indicates that an aircraft meets the RNP type prescribed for the route segment(s), route(s) and/or area concerned.

Field Type 10 (cont.)

OBLIQUE STROKE

(b) *Surveillance Equipment*

ONE OR TWO LETTERS to describe the serviceable surveillance equipment carried:

SSR equipment

- N Nil
- A Transponder — Mode A (4 digits — 4 096 codes)
- C Transponder — Mode A (4 digits — 4 096 codes) and Mode C
- X Transponder — Mode S without both aircraft identification and pressure-altitude transmission
- P Transponder — Mode S, including pressure-altitude transmission, but no aircraft identification transmission
- I Transponder — Mode S, including aircraft identification transmission, but no pressure-altitude transmission
- S Transponder — Mode S, including both pressure-altitude and aircraft identification transmission

ADS equipment

- D ADS capability

Examples: -S/A
-SCHJ/CD
-SAFJ/SD

Field Type 13 — Departure Aerodrome and Time

FIELD TYPE 13

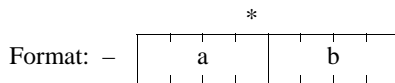

SINGLE HYPHEN

| Previous type of field or symbol | This type of field is used in | Next type of field or symbol |
|----------------------------------|-------------------------------|------------------------------|
| 10 | ALR | 15 |
| 10 | FPL | 15 |
| 7 | CHG | 16 |
| 7 | CNL | 16 |
| 7 | DLA | 16 |
| 7 | DEP | 16 |
| 7 | ARR | (16)** 17 |
| 10 | CPL | 14 |
| 7 | EST | 14 |
| 7 | CDN | 16 |
| 7 | ACP | 16 |
| 7 | RQP | 16 |
| 7 | RQS | 16 |
| 7 | SPL | 16 |

** Only in case of a diversionary landing

(a) *Departure Aerodrome*

4 LETTERS, being

the ICAO four-letter location indicator allocated to the departure aerodrome, or

ZZZZ if no ICAO location indicator has been allocated (see Note 1) or if the departure aerodrome is not known, or

AFIL if the flight plan has been filed in the air (see Note 2).

Note 1.— If ZZZZ is used, the name of the departure aerodrome is to be shown in the Other Information Field (see Field Type 18) if this Field Type is contained in the message.

Note 2.— If AFIL is used, the ATS unit from which supplementary flight data can be obtained is to be shown in the Other Information Field (Field Type 18).

* This field shall be terminated here in message types CHG, CNL, ARR, CPL, EST, CDN, ACP and RQS. It shall be terminated here in message type RQP if the estimated off-block time is not known.

(b) *Time*

4 NUMERICS giving

the estimated off-block time at the aerodrome in (a) in FPL and DLA messages transmitted before departure and in RQP message, if known, or

the actual time of departure from the aerodrome in (a) in ALR, DEP and SPL messages, or

the actual or estimated time of departure from the first point shown in the Route Field (see Field Type 15) in FPL messages derived from flight plans filed in the air, as shown by the letters AFIL in (a).

Examples: —EHAM0730
—AFIL1625

Field Type 14 — Estimate Data

| |
|---------------|
| FIELD TYPE 14 |
|---------------|

Format: –

| |
|---|
| a |
|---|

| | | | |
|---|---|---|---|
| b | c | d | e |
|---|---|---|---|

| Previous type of field or symbol | This type of field is used in | Next type of field or symbol |
|----------------------------------|-------------------------------|------------------------------|
| 13 | CPL | 15 |
| 13 | EST | 16 |

SINGLE HYPHEN

(a) *Boundary Point (see Note 1)*

The BOUNDARY POINT expressed either by a designator consisting of 2 to 5 characters, in Geographical Coordinates, in Abbreviated Geographical Coordinates, or by bearing and distance from a designated point (e.g. a VOR).

Note 1.— This point may be an agreed point located close to, rather than on, the FIR boundary.

Note 2.— See 1.6 for data conventions.

OBLIQUE STROKE

(b) *Time at Boundary Point*

4 NUMERICS giving the estimated time at the Boundary Point.

(c) *Cleared Level*

F followed by 3 NUMERICS, or

S followed by 4 NUMERICS, or

A followed by 3 NUMERICS, or

M followed by 4 NUMERICS

See data conventions in 1.6 of this Appendix.

giving the cleared level at which the aircraft will cross the Boundary Point, if in level cruising flight, or the cleared level to which it is proceeding, if climbing or descending at the Boundary Point.

* This field will be terminated here if the aircraft will cross the Boundary Point in level cruising flight.

Field Type 14 (cont.)

(d) *Supplementary Crossing Data*

A LEVEL, expressed as in (c), at or above which or at or below which (see (e)) the aircraft will cross the Boundary Point.

(e) *Crossing Condition*

1 LETTER as follows:

A if the aircraft will cross the Boundary Point at or above the level in (d),
or

B if the aircraft will cross the Boundary Point at or below the level in (d).

Examples: -LN/1746
-F160
-CLN/1831F240F180A
-5420N05000W/0417F290
-LNX/1205F160F200B
-ZD126028/0653F130

Field Type 15 — Route

FIELD TYPE 15

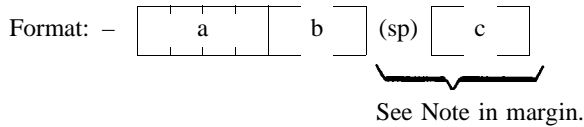

| Previous type of field or symbol | This type of field is used in | Next type of field or symbol |
|----------------------------------|-------------------------------|------------------------------|
| 13 | ALR | 16 |
| 13 | FPL | 16 |
| 14 | CPL | 16 |

SINGLE HYPHEN

(a) *Cruising Speed or Mach Number*

The True Airspeed for the first or the whole cruising portion of the flight, in terms of:

K followed by 4 NUMERICS giving the True Airspeed in kilometres per hour, or

N followed by 4 NUMERICS giving the True Airspeed in knots, or

when so prescribed by the appropriate ATS authority, M followed by 3 NUMERICS giving the Mach Number to the nearest hundredth of unit Mach.

(b) *Requested Cruising Level*

F followed by 3 NUMERICS, or
 S followed by 4 NUMERICS, or
 A followed by 3 NUMERICS, or
 M followed by 4 NUMERICS, or

} See data conventions in 1.6 of this Appendix.

VFR.

SPACE

followed by a string of elements/groups of elements of the following seven types separated by SPACES, in whatever sequence is necessary to describe the route in an unambiguous manner (see Appendix 2, Section 2).

Note.— Further element groups of elements (c) should be added, as necessary, each to be preceded by a space.

Field Type 15 (cont.)

(c1) *Standard Departure Route*

The designator for the Standard Departure Route from the aerodrome of departure to the first significant point on the defined route to be flown.

Note 1.— See data convention in 1.6.3.1 a) of this Appendix.

Note 2.— Element (c1) may be followed by (c3) or (c4).

Note 3.— Standard Departure Route need be included only where appropriate.

(c2) *ATS Route Designator*

Note 1.— See data convention in 1.6.3.1 a) of this Appendix.

Note 2.— Element (c2) may be followed by (c3) or (c4) only.

(c3) *Significant Point*

Note.— See alternative data conventions in 1.6.3.1 b), c), d) and e) of this Appendix.

(c4) *Significant Point/Cruising Speed and Cruising Level*

SIGNIFICANT POINT (as in element (c3))

OBLIQUE STROKE

CRUISING SPEED OR MACH NUMBER (as in element (a))

REQUESTED CRUISING LEVEL (as in element (b)).

Field Type 15 (cont.)

(c5) *Indicator*

VFR if a change to VFR is to be made at the preceding point, or

IFR if a change to IFR is to be made at the preceding point, or

DCT if the flight to the next point will be outside a designated route, unless both points are defined by geographical coordinates or by bearing and distance.

T if the route description is truncated at the preceding point and the remainder is to be sought in a previously transmitted FPL or other data.

Note 1.— Element (c5) may follow (c3) or (c4) and (c6) only.

Note 2.— When used, T must conclude the Route Field.

(c6) *Cruise Climb*

The letter C followed by an oblique stroke; then the point at which cruise climb is planned to start, expressed exactly as in (c3) above, followed by an oblique stroke; then the speed to be maintained during cruise climb expressed exactly as in (a) above followed by *the two levels* defining the layer to be occupied during cruise climb; each level expressed as in (b) above, or the level above which cruise climb is planned, followed by the letters PLUS, without a space between them.

(c7) *Standard Arrival Route*

The designator for the Standard Arrival Route from the point of leaving the defined route to the point at which the approach procedure is initiated.

Note.— Standard Arrival Route need only be included where appropriate.

Examples: -K0410S1500 A4 CCV R11
 -K0290A120 BR 614
 -N0460F290 LEK2B LEK UA6 FNE UA6 XMM/M078F330 UA6N PON UR10N
 CHW UA5 NTS DCT 4611N00412W DCT STG UA5 FTM FATIM1A
 -M082F310 BCN1G BCN UG1 52N015W 52N020W 52N030W 50N040W
 49N050W DCT YQX
 -N0420F310 R10 UB19 CGC UA25 DIN/N0420F330 UR14 IBY UR1 MID

Field Type 16 — Destination Aerodrome and Total Estimated Elapsed Time, Alternate Aerodrome(s)

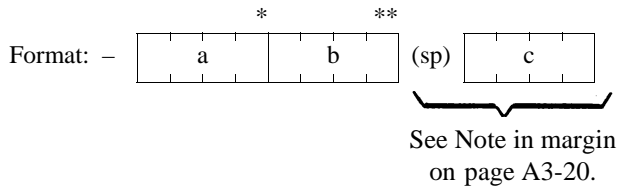

SINGLE HYPHEN

(a) *Destination Aerodrome*

4 LETTERS, being

the ICAO four-letter location indicator allocated to the destination aerodrome, or

ZZZZ if no ICAO location indicator has been allocated.

Note.— If ZZZZ is used, the name of the destination aerodrome is to be shown in the Other Information Field (see Field Type 18).

* This field is to be terminated here in all message types other than ALR, FPL and SPL.

(b) *Total Estimated Elapsed Time*

4 NUMERICS, giving

the total estimated elapsed time.

** This field may be terminated here in FPL messages when so agreed between the ATS units concerned or prescribed on the basis of regional air navigation agreements.

FIELD TYPE 16

| <i>Previous type of field or symbol</i> | <i>This type of field is used in</i> | <i>Next type of field or symbol</i> |
|---|--------------------------------------|-------------------------------------|
| 15 | ALR | 18 |
| 15 | FPL | 18 |
| 13 | CHG | 22 |
| 13 | CNL |) |
| 13 | DLA |) |
| 13 | DEP |) |
| 13 | ARR*** | 17 |
| 15 | CPL | 18 |
| 14 | EST |) |
| 13 | CDN | 22 |
| 13 | ACP |) |
| 13 | RQS |) |
| 13 | SPL | 18 |

*** Only in case of a diversionary landing.

Field Type 16 (cont.)

SPACE

(c) *Alternate Aerodrome(s)*

4 LETTERS, being

the ICAO four-letter location indicator allocated to an alternate aerodrome,
or

ZZZZ if no ICAO location indicator has been allocated.

*Note.— If ZZZZ is used, the name of the alternate aerodrome is to be shown
in the Other Information Field (see Field Type 18).*

*Note.— One further element of (c)
should be added, as necessary,
preceded by a space.*

Examples: -EINN0630
-EHAM0645 EBBR
-EHAM0645 EBBR EDDL

Field Type 17 — Arrival Aerodrome and Time

FIELD TYPE 17

Format: –

| | |
|---|---|
| a | b |
|---|---|

 (sp)

| |
|---|
| c |
|---|

| Previous type of field or symbol | This type of field is used in | Next type of field or symbol |
|----------------------------------|-------------------------------|------------------------------|
| 13 (16)** | ARR |) |

SINGLE HYPHEN

(a) *Arrival Aerodrome*
4 LETTERS, being
the ICAO four-letter location indicator allocated to the arrival aerodrome, or ZZZZ if no ICAO location indicator has been allocated.

(b) *Time of Arrival*
4 NUMERICS, giving
the actual time of arrival.

* This field is to be terminated here if an ICAO location indicator has been allocated to the arrival aerodrome.

** Only in case of a diversionary landing.

SPACE

(c) *Arrival Aerodrome*
Name of arrival aerodrome, if ZZZZ is inserted in (a).

Examples: –EHAM1433
–ZZZZ1620 DEN HELDER

Field Type 18 — Other Information

| |
|---------------|
| FIELD TYPE 18 |
|---------------|

Format: –

| |
|---|
| a |
|---|

–

| |
|--|
| |
|--|

^{or}

| |
|--|
| |
|--|

 (sp)

| |
|--|
| |
|--|

| |
|--|
| |
|--|

 (sp) * (sp)

| |
|--|
| |
|--|

| |
|--|
| |
|--|

(* additional elements as necessary)

| Previous type of field or symbol | This type of field is used in | Next type of field or symbol |
|----------------------------------|-------------------------------|------------------------------|
| 16 | ALR | 19 |
| 16 | FPL |) |
| 16 | CPL |) |
| 16 | SPL | 19 |

SINGLE HYPHEN

| | |
|-----|----------------------------------|
| (a) | 0 (zero) if no other information |
|-----|----------------------------------|

OR

Any other necessary information in the preferred sequence shown hereunder, in the form of the appropriate abbreviation followed by an oblique stroke and the information to be recorded:

| | |
|------|--|
| EET/ | Significant points or FIR boundary designators and accumulated estimated elapsed times over such points or FIR boundaries, when so prescribed on the basis of regional air navigation agreements, or by the appropriate ATS authority. |
| | Examples: EET/CAP0745 XYZ0830 EET/EINN0204 |

| | |
|------|--|
| RIF/ | The route details to the revised destination aerodrome, followed by the ICAO four-letter location indicator of the aerodrome. The revised route is subject to reclearance in flight. |
| | Examples: RIF/DTA HEC KLAX RIF/ESP G94 CLA APPH RIF/LEMD |

| | |
|------|---|
| REG/ | The registration markings of the aircraft, only if necessary and if different from the aircraft identification in Item 7. |
|------|---|

| | |
|------|---|
| SEL/ | SELCAL Code, if so prescribed by the appropriate ATS authority. |
|------|---|

| | |
|------|--|
| OPR/ | Name of the operator, if not obvious from the aircraft identification in Item 7. |
|------|--|

Field Type 18 (cont.)

| | |
|-------|---|
| STS/ | Reason for special handling by ATS e.g. hospital aircraft, one engine inoperative, e.g. STS/HOSP, STS/ONE ENG INOP. |
| TYP/ | Types(s) of aircraft, preceded if necessary by number(s) of aircraft, if ZZZZ is used in Item 9. |
| PER/ | Aircraft performance data, if so prescribed by the appropriate ATS authority. |
| COM/ | Significant data related to communication equipment as required by the appropriate ATS authority, e.g. COM/UHF only. |
| DAT/ | Significant data related to data link capability, using one or more of the letters S, H, V and M, e.g. DAT/S for satellite data link, DAT/H for HF data link, DAT/V for VHF data link, DAT/M for SSR Mode S data link. |
| NAV/ | Significant data related to navigation equipment as required by the appropriate ATS authority. |
| DEP/ | Name of departure aerodrome, if ZZZZ is inserted in Item 13, or the ICAO four-letter location indicator of the location of the ATS unit from which supplementary flight plan data can be obtained, if AFIL is inserted in Item 13. |
| DEST/ | Name of destination aerodrome, if ZZZZ is inserted in Item 16. |
| ALTN/ | Name of destination alternate aerodrome(s), if ZZZZ is inserted in Item 16. |
| RALT/ | Name of en-route alternate aerodrome(s). |
| CODE/ | Aircraft address (expressed in the form of an alphanumeric code of six hexadecimal characters) when required by the appropriate ATS authority. Example: "F00001" is the lowest aircraft address contained in the specific block administered by ICAO. |
| RMK/ | Any other plain language remarks when required by the appropriate ATS authority or deemed necessary by the pilot-in-command for the provision of air traffic services. |

Examples: -0

-EET/15W0315 20W0337 30W0420 40W0502

-STS/ONE ENG INOP

-DAT/S

Field Type 19 — Supplementary Information

| |
|---------------|
| FIELD TYPE 19 |
|---------------|

Format: – (sp) (sp) * (sp)
 (* additional elements as necessary)

| <i>Previous type of field or symbol</i> | <i>This type of field is used in</i> | <i>Next type of field or symbol</i> |
|---|--------------------------------------|-------------------------------------|
| 18 | ALR | 20 |
| 18 | SPL |) |

This field consists of such supplementary information as is available, organized into a string of elements separated by spaces.

The permissible elements in their proper sequence are:

SINGLE HYPHEN

| |
|---|
| (a) E/ followed by 4 NUMERICS giving the fuel endurance in hours and minutes. |
|---|

| |
|---|
| (b) P/ followed by 1, 2 or 3 NUMERICS giving the total number of persons on board, when so prescribed by the appropriate ATS authority. |
|---|

| |
|--|
| (c) R/ followed by one or more of the following, without spaces: U if frequency 243.0 MHz (UHF) is available, V if frequency 121.5 MHz (VHF) is available, E if emergency locator transmitter (ELT) is available. |
|--|

| |
|---|
| (d) S/ followed by one or more of the following, without spaces: P if polar survival equipment is carried, D if desert survival equipment is carried, M if maritime survival equipment is carried, J if jungle survival equipment is carried. |
|---|

| |
|---|
| (e) J/ followed by one or more of the following, without spaces: L if the life jackets are equipped with lights, F if they are equipped with fluorescein, followed by space followed by U if any life jacket radio is equipped with UHF on frequency 243.0 MHz, V if any life jacket radio is equipped with VHF on frequency 121.5 MHz. |
|---|

Field Type 19 (cont.)

(f) D/ followed by one or more of the following, separated by spaces:
2 NUMERICS giving the number of dinghies carried,
3 NUMERICS giving the total capacity, in persons carried, of all dinghies.
C if dinghies are covered.
The colour of the dinghies (e.g. RED).

(g) A/ followed by one or more of the following, separated by spaces:
The colour of the aircraft.
Significant markings (this may include the aircraft registration).

(h) N/ followed by plain language indicating any other survival equipment carried and any other useful remarks.

(i) C/ followed by the name of the pilot-in-command.

Example: -E/0745 P/6 R/VE S/M J/L D/2 8 C YELLOW
A/YELLOW RED TAIL N145E C/SMITH

Field Type 20 — Alerting Search and Rescue Information

| |
|---------------|
| FIELD TYPE 20 |
|---------------|

Format: – [] [] (sp) [] [] (sp) * (sp) [] []
 (*EIGHT elements in all)

| <i>Previous type of field or symbol</i> | <i>This type of field is used in</i> | <i>Next type of field or symbol</i> |
|---|--------------------------------------|-------------------------------------|
| 19 | ALR |) |

This field consists of the following specified sequence of elements separated by spaces. Any information not available should be shown as “NIL” or “NOT KNOWN” and not simply omitted.

SINGLE HYPHEN

- (a) *Identity of Operator*
 The ICAO two-letter designator of the aircraft operating agency or, if this has not been assigned, the name of the operator.

- (b) *Unit which made Last Contact*
 6 LETTERS consisting of the 4-letter ICAO location indicator followed by the 2-letter designator which together identify the ATS unit which made the last two-way contact or, if these are not available, some other description of the unit.

- (c) *Time of Last Two-way Contact*
 4 NUMERICS giving the time of the last two-way contact.

- (d) *Frequency of Last Contact*
 NUMERICS as necessary giving the transmitting/receiving frequency of the last contact.

- (e) *Last Reported Position*
 The last reported position expressed in one of the data conventions of 1.6 of this Appendix followed by the time over that position.

Field Type 20 (cont.)

(f) *Method of Determining Last Known Position*

Plain language text as necessary.

(g) *Action Taken by Reporting Unit*

Plain language text as necessary.

(h) *Other Pertinent Information*

Plain language text as necessary.

Example: -USAF LGGGZAZX 1022 126.7 GN 1022
PILOT REPORT OVER NDB ATS UNITS
ATHENS FIR ALERTED NIL

Field Type 21 — Radio Failure Information

| |
|---------------|
| FIELD TYPE 21 |
|---------------|

Format: – [] [] (sp) [] [] (sp) * (sp) [] []
 (*SIX elements in all)

| <i>Previous type of field or symbol</i> | <i>This type of field is used in</i> | <i>Next type of field or symbol</i> |
|---|--------------------------------------|-------------------------------------|
| 7 | RCF |) |

This field consists of the following specified sequence of elements preceded by a single hyphen and separated by spaces. Any information not available is to be shown as “NIL” or “NOT KNOWN” and not simply omitted.

SINGLE HYPHEN

| |
|---|
| <p>(a) <i>Time of Last Two-way Contact</i></p> <p>4 NUMERICS giving the time of the last two-way contact with the aircraft.</p> |
|---|

| |
|---|
| <p>(b) <i>Frequency of Last Contact</i></p> <p>NUMERICS as necessary giving the transmitting/receiving frequency of the last two-way contact with the aircraft.</p> |
|---|

| |
|--|
| <p>(c) <i>Last Reported Position</i></p> <p>The last reported position expressed in one of the data conventions of 1.6 of this Appendix.</p> |
|--|

| |
|---|
| <p>(d) <i>Time at Last Reported Position</i></p> <p>4 NUMERICS giving the time at the last reported position.</p> |
|---|

| |
|---|
| <p>(e) <i>Remaining COM Capability</i></p> <p>LETTERS as necessary identifying the remaining COM capability of the aircraft, if known, using the convention of Field Type 10, or in plain language.</p> |
|---|

| |
|--|
| <p>(f) <i>Any Necessary Remarks</i></p> <p>Plain language text as necessary.</p> |
|--|

Example: –1232 121.3 CLA 1229 TRANSMITTING ONLY 126.7
 LAST POSITION CONFIRMED BY RADAR

Field Type 22 — Amendment

Format: – a / b

SINGLE HYPHEN

(a) *Field Indicator*

ONE OR TWO NUMERICS giving the type number of the field to be amended.

OBLIQUE STROKE

(b) *Amended Data*

The complete and amended data of the field indicated in (a), constructed as specified for that field.

Example of amendment of Field Type 8 (Flight Rules and Type of Flight) to IN:

–8/IN

Example of amendment of Field Type 14 (Estimate Data):

–14/ENO/0145F290A090A

Example of amendment of Fields Type 8 (Flight Rules and Type of Flight) and 14 (Estimate Data):

–8/I-14/ENO/0148F290A110A

FIELD TYPE 22

| <i>Previous type of field or symbol</i> | <i>This type of field is used in</i> | <i>Next type of field or symbol</i> |
|---|--------------------------------------|-------------------------------------|
| 16 | CHG | *22 or) |
| 16 | CDN | *22 or) |

* Indicates that further fields of this type may be added.

STANDARD ATS MESSAGES AND THEIR COMPOSITION

| DESIGNATOR | | MESSAGE FIELDS | | | | | | | | | | | | | | | | | | | | | | FIELD TYPE NUMBERS | |
|-----------------------------------|-----|----------------|---|---|---|---|---|---|---|---|----|----|----|----|----|----|----|----|----|----|----|----|----|--------------------|---|
| MESSAGE TYPE | | 1 | 2 | 3 | 4 | 5 | 6 | 7 | 8 | 9 | 10 | 11 | 12 | 13 | 14 | 15 | 16 | 17 | 18 | 19 | 20 | 21 | 22 | | |
| Alerting | ALR | | | 3 | | 5 | | 7 | 8 | 9 | 10 | | | 13 | | 15 | 16 | | 18 | 19 | 20 | | | 21 | Emergency messages |
| Radiocommunication failure | RCF | | | 3 | | | | 7 | | | | | | | | | | | | | | | | 21 | |
| Filed flight plan | FPL | | | 3 | | | | 7 | 8 | 9 | 10 | | | 13 | | 15 | 16 | | 18 | | | | | | Filed flight plan messages and associated update messages |
| Delay | DLA | | | 3 | | | | 7 | | | | | | 13 | | | 16 | | | | | | | | |
| Modification | CHG | | | 3 | | | | 7 | | | | | | 13 | | | 16 | | | | | | | 22 | |
| Flight plan cancellation | CNL | | | 3 | | | | 7 | | | | | | 13 | | | 16 | | | | | | | | |
| Departure | DEP | | | 3 | | | | 7 | | | | | | 13 | | | 16 | | | | | | | | |
| Arrival | ARR | | | 3 | | | | 7 | | | | | | 13 | | | 16 | 17 | | | | | | | |
| Current flight plan | CPL | | | 3 | | | | 7 | 8 | 9 | 10 | | | 13 | 14 | 15 | 16 | | 18 | | | | | | Co-ordination messages |
| Estimate | EST | | | 3 | | | | 7 | | | | | | 13 | 14 | | 16 | | | | | | | | |
| Co-ordination | CDN | | | 3 | | | | 7 | | | | | | 13 | | | 16 | | | | | | | 22 | |
| Acceptance | ACP | | | 3 | | | | 7 | | | | | | 13 | | | 16 | | | | | | | | |
| Logical acknowledgement message | LAM | | | 3 | | | | 7 | | | | | | | | | | | | | | | | | |
| Request flight plan | RQP | | | 3 | | | | 7 | | | | | | 13 | | | 16 | | | | | | | | Supplementary messages |
| Request supplementary flight plan | RQS | | | 3 | | | | 7 | | | | | | 13 | | | 16 | | | | | | | | |
| Supplementary flight plan | SPL | | | 3 | | | | 7 | | | | | | 13 | | | 16 | | 18 | 19 | | | | | |



This field begins a new line when the message is printed in page teletypewriter form.



This field is repeated as necessary.

RULES FOR THE COMPOSITION OF ATS MESSAGES

(See Sections 1.3 to 1.8 of this Appendix)

Composition of the standard types of message

The composition of each standard type of message, expressed as a standardized sequence of fields of data shall be as prescribed in the reference table on this page. Each message shall contain all the fields prescribed.

Composition of the standard types of field

The composition of each standard type of field, expressed as a standardized sequence of elements of data, or in some cases as a simple element, shall be as prescribed in the field tables on pages A3-5 to A3-29.

Note.— Each type of field contains at least one mandatory element and, except in Field Type 9, this is the first or only element in the field. The rules for the inclusion or omission of optional elements are indicated in the field tables.

Structuring and punctuation

The beginning of the ATS data shall be indicated on page copy by an open bracket '(', which constitutes the Start-of-ATS-Data Signal. This signal shall be used only as the printed character immediately preceding the Message Type Designator.

Note.— In teletypewriter operation using International Telegraph Alphabet No. 2, the open bracket is transmitted as the Figures Case of Signal No. 11. On some teletypewriter machines, this will print as a symbol other than '(', but this variation will be local and of no consequence. Where higher level codes are employed, the character printing as '(' is used.

The beginning of each field, other than the first, shall be indicated by a single hyphen '-', which constitutes the Start-of-Field Signal. This signal shall be used only as the printed character preceding the first element of ATS data in each field.

Note.— In teletypewriter operation using International Telegraph Alphabet No. 2, single hyphen is transmitted as the Figures Case of Signal No. 1. On some teletypewriter machines, this will print as a symbol other than '-', but this variation will be local and of no consequence. Where higher level codes are employed, the character printing as '-' is used.

Elements within a field shall be separated by an oblique stroke '/' (see Note 1) or a space (sp) (see Note 2) only where so prescribed in the field tables on pages A3-5 to A3-29.

Note 1.— In teletypewriter operation using International Telegraph Alphabet No. 2, the oblique stroke is transmitted as the Figures Case of Signal No. 24. On some teletypewriter machines, this will print as a symbol other than '/'; but this variation will be local and of no consequence. Where higher level codes are employed, the character printing as '/' is used.

Note 2.— In teletypewriter operation using International Telegraph Alphabet No. 2, the space is transmitted as Signal No. 31. Where higher level codes

are employed, the character which causes a space on page copy is to be used.

The end of the ATS data shall be indicated by a close bracket ')', which constitutes the End-of-ATS-Data Signal. This signal shall be used only as the printed character immediately following the last field in the message.

Note.— In teletypewriter operation using International Telegraph Alphabet No. 2, the close bracket is transmitted as Signal No. 12. On some teletypewriter machines, this will print as a symbol other than ')'; but this variation will be local and of no consequence. Where higher level codes are employed, the character printing as ')' is to be used.

When the standard ATS messages are prepared in teletypewriter form, an Alignment Function (two Carriage Returns followed by one Line Feed) shall be inserted:

- (a) prior to each of the fields so annotated in the reference table on this page;
- (b) in Fields Type 5 (Description of Emergency), 15 (Route), 18 (Other Information), 19 (Supplementary Information), 20 (Alerting Search and Rescue Information), 21 (Radio Failure Information) and 22 (Amendment), whenever it is necessary to begin a new line on page copy (see Note). In such cases, the Alignment Function shall be inserted between two data elements and shall not divide an element.

Note.— Annex 10 prescribes that a line of teletypewriter copy shall not contain more than 69 characters.

Data conventions

Most of the conventions to be used in the expression of ATS data in the messages are prescribed in the field tables on pages A3-5 to A3-29, but the conventions for the expression of level, position and route data are given below.

The expression of level data

Four alternative conventions are available for the expression of level data:

- (a) "F" followed by 3 decimal numerics: indicates a Flight Level Number, i.e. Flight Level 340 is expressed as "F340";
- (b) "S" followed by 4 decimal numerics: indicates a Standard Metric Level in tens of metres, i.e. Standard Metric Level 11 300 m (Flight Level 370) is expressed as "S1130";
- (c) "A" followed by 3 decimal numerics: indicates altitude in hundreds of feet, i.e. an altitude of 4 500 feet is expressed as "A045";
- (d) "M" followed by 4 decimal numerics: indicates altitude in tens of metres, i.e. an altitude of 8 100 metres is expressed as "M0810".

The expression of position or route

The following alternative data conventions shall be used for the expression of position or route:

- (a) from 2 to 7 characters, being the coded designator assigned to an ATS route to be flown;
- (b) from 2 to 5 characters, being the coded designator assigned to an en-route point;
- (c) 4 numerics describing latitude in tens and units of degrees and tens and units of minutes, followed by 5 numerics describing longitude in hundreds, tens and units of degrees and tens and units of minutes, followed by "E" (East) or "W" (West). The correct number of numerics is to be made up, where necessary, by insertion of zeros, e.g. "4620N07805W";
- (d) 2 decimal numerics describing latitude in degrees, followed by "N" (North) or "S" (South), followed by 3 decimal numerics describing longitude in degrees, followed by "E" (East) or "W" (West). Again, the correct number of numerics is to be made up, where necessary, by insertion of zeros, e.g. "46N078W";
- (e) 2 or 3 characters being the coded identification of a navigation aid (normally a VOR), followed by 3 decimal numerics giving the bearing from the point in degrees magnetic followed by 3 decimal numerics giving the distance from the point in nautical miles. The correct number of numerics is to be made up, where necessary, by insertion of zeros, e.g. a point at 180° magnetic at a distance of 40 nautical miles from VOR "FOJ" would be expressed as "FOJ180040".

The detail of the fields

The elements of data prescribed or permitted to be included in each type of field, together with a prescription of the conditions or options permitted, are shown on pages A3-5 to A3-29.

A key appears at the right-hand side of each of the field pages; this key permits the sequence of fields in each type of message to be followed.

On the field pages,

elements with a fixed number of characters are shown diagrammatically as (three characters in this example)

| | | |
|--|--|--|
| | | |
|--|--|--|

elements of variable length are shown as

| | |
|--|--|
| | |
|--|--|

Accuracy in the preparation of ATS messages

Where the standard ATS messages are transmitted by teletypewriter channels in areas where ATC computers are known to be in use, the formats and data conventions prescribed in the field tables on pages A3-5 to A3-29 shall be adhered to rigorously.

2. Examples of ATS messages

2.1 Table of contents

| <i>Message category</i> | <i>Message type</i> | <i>Message type designator</i> | <i>Paragraph</i> |
|---|-----------------------------------|--------------------------------|------------------|
| Emergency | Alerting | ALR | 2.2.1 |
| | Radio communication failure | RCF | 2.2.2 |
| Filed flight plan and associated update | Filed flight plan | FPL | 2.3.1 |
| | Modification | CHG | 2.3.2 |
| | Cancellation | CNL | 2.3.3 |
| | Delay | DLA | 2.3.4 |
| | Departure | DEP | 2.3.5 |
| | Arrival | ARR | 2.3.6 |
| Co-ordination | Current flight plan | CPL | 2.4.1 |
| | Estimate | EST | 2.4.2 |
| | Co-ordination | CDN | 2.4.3 |
| | Acceptance | ACP | 2.4.4 |
| | Logical acknowledgement | LAM | 2.4.5 |
| Supplementary | Request flight plan | RQP | 2.5.1 |
| | Request supplementary flight plan | RQS | 2.5.2 |
| | Supplementary flight plan | SPL | 2.5.3 |

Note 1.— Only the ATS information, i.e. in AFTN messages only the AFTN text, is shown.

Note 2.— The numbers in the composition diagrams correspond to the field type numbers used in Section 1 of this Appendix.

2.2 Emergency messages

2.2.1 Alerting (ALR) message

2.2.1.1 Composition

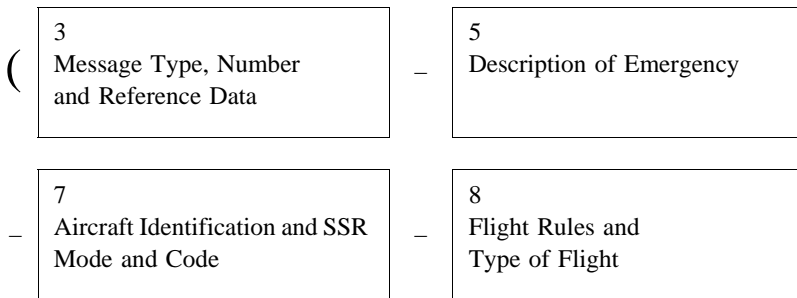

– 9
Type of Aircraft and
Wake Turbulence Category

– 10
Equipment

13
Departure Aerodrome
and Time

– 15
Route (using more than one line if necessary)

16
Destination Aerodrome and Total Estimated Elapsed Time, Alternate Aerodrome(s)

– 18
Other Information (using more than one line if necessary)

– 19
Supplementary Information (using more than one line if necessary)

– 20
Alerting Search and Rescue Information (using more than one line if necessary)

2.2.1.2 Example

The following is an example of an alerting message relating to an uncertainty phase, sent by Athens Approach Control to Belgrade Centre and other ATS units, in respect of a flight from Athens to Munich.

```
(ALR-INCERFA/LGGGZAZX/OVERDUE
-FOX236/A3600-IM
-C141/H-S/CD
-LGAT1020
-N0430F220 B9 3910N02230W/N0415F240 B9 IVA/N0415F180 B9
-EDDM0227 EDDF
-EET/LYBE0020 EDM10133 REG/A43213 OPR/USAF RMK/NO
POSITION REPORT SINCE DEP PLUS 2 MINUTES
```

-E/0720 P/12 R/UV J/LF D/02 014 C ORANGE A/SILVER C/SIGGAH
 -USAF LGGGZAZX 1022 126.7 GN 1022 PILOT REPORT OVER NDB ATS
 UNITS ATHENS FIR ALERTED NIL)

2.2.1.2.1 *Meaning*

Alerting message — uncertainty phase declared by Athens due no position reports and no radio contact since two minutes after departure — aircraft identification FOX236 — IFR, military flight — Starlifter, heavy wake turbulence category, equipped with standard communications, navigation and approach aid equipment for the route, SSR transponder with Modes A (4 096 code capability) and C — ADS capability — last assigned Code 3624 — departed Athens 1020 UTC — cruising speed for first portion of route 430 knots, first requested cruising level FL 220 — proceeding on airway Blue 9 to 3910N2230W where TAS would be changed to 415 knots — proceeding on airway Blue 9 to Ivanic Grad VOR where FL 180 would be requested, maintaining TAS of 415 knots — proceeding on airway Blue 9 to Munich, total estimated elapsed time 2 hours and 27 minutes — alternate is Frankfurt — accumulated estimated elapsed times at the Belgrade and Munich FIR boundaries 20 minutes and 1 hour and 33 minutes respectively — aircraft registration A43213 — the aircraft is operated by the USAF — no position report has been received since 2 minutes after departure — endurance 7 hours and 20 minutes after take-off — 12 persons on board — portable radio equipment working on VHF 121.5 MHz and UHF 243 MHz is carried — life jackets fitted with lights and fluorescein are carried — 2 dinghies with orange covers are carried, have a total capacity for 14 persons — aircraft colour is silver — pilot’s name is SIGGAH — operator is USAF — Athens approach control was the last unit to make contact at 1022 UTC on 126.7 MHz when pilot reported over GN runway locator beacon — Athens approach control have alerted all ATS units within Athens FIR — no other pertinent information.

2.2.2 *Radio communication failure (RCF) message*

2.2.2.1 *Composition*

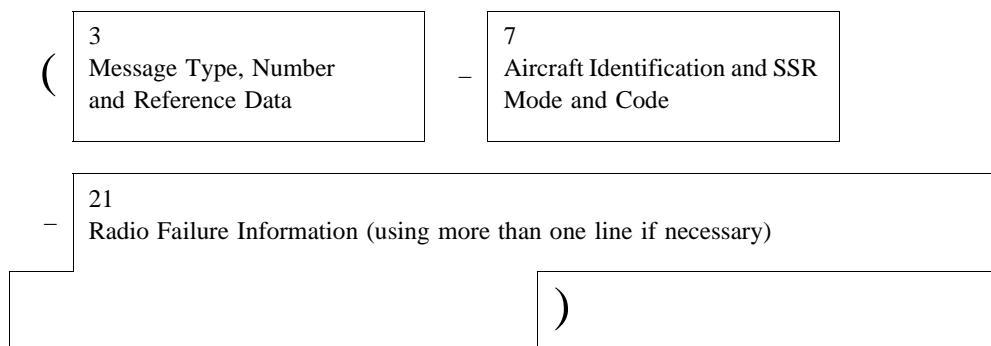

2.2.2.2 *Example*

The following is an example of a message sent from London to Amsterdam informing that centre of a radio communication failure on a flight that has been cleared to it. The related flight plan shows that the aircraft is not equipped with an SSR transponder.

(RCF-GAGAB
 -1231 121.3 CLA 1229 TRANSMITTING ONLY 126.7 MHZ LAST POSITION CONFIRMED BY RADAR)

2.2.2.2.1 *Meaning*

Radio communication failure message — aircraft identification GAGAB — no SSR Code assigned — last communication with London Centre 1232 UTC on 121.3 MHz — last reported position was Clacton VOR, at 1229 UTC — remaining COM capability: last heard transmitting on 126.7 MHz — position report at Clacton observed by radar.

2.3 Filed flight plan and associated update messages

2.3.1 Filed flight plan (FPL) message

2.3.1.1 Composition

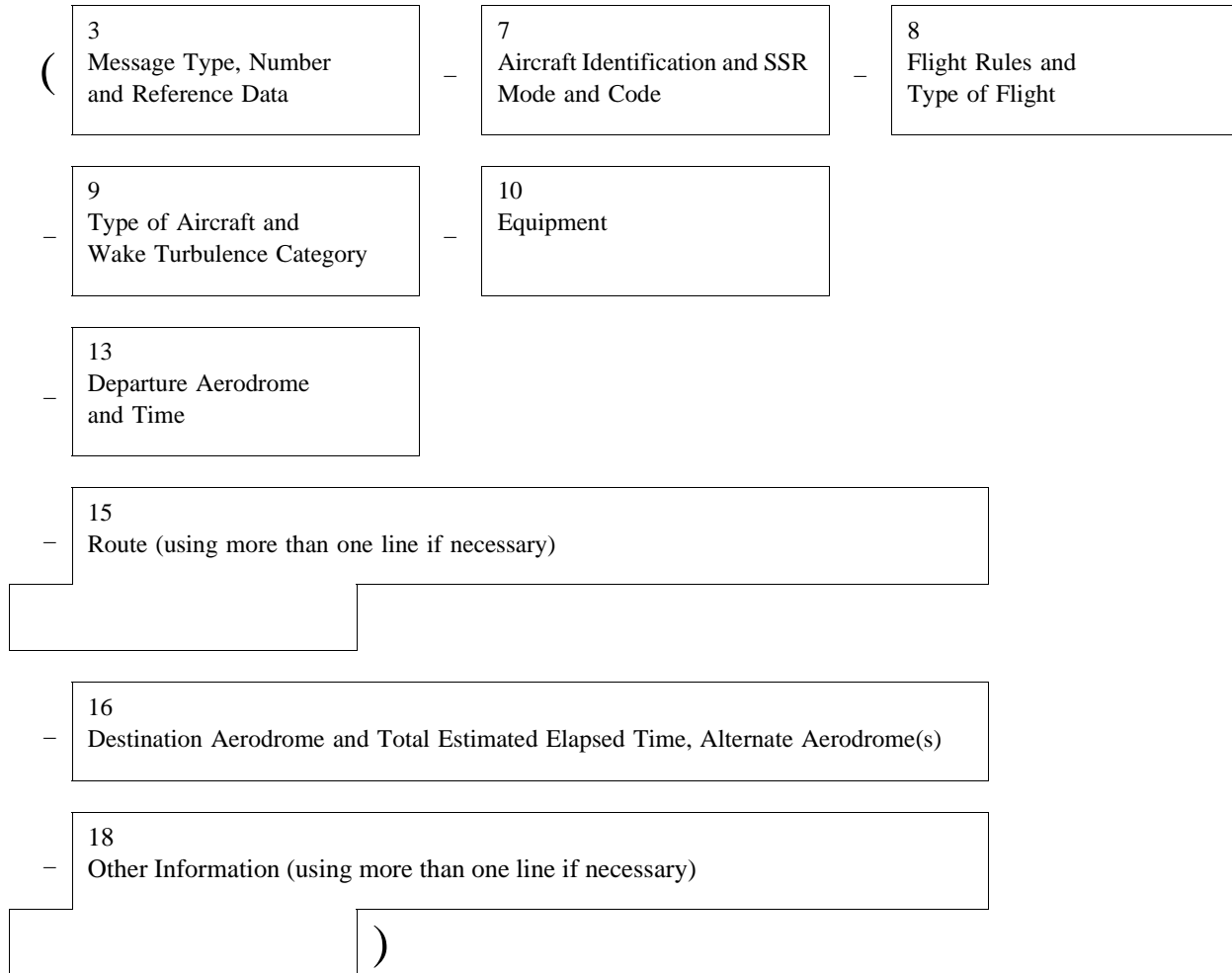

2.3.1.2 Example

The following is an example of a filed flight plan message sent by London Airport to Shannon, Shanwick and Gander Centres. The message may also be sent to the London Centre or the data may be passed to that centre by voice.

```
(FPL-TPR101-IS
-B707M-CHOPV/CD
-EGLL1400
-N0450F310 G1 UG1 STU285036/M082F310 UG1 52N015W
52N020W 52N030W 50N040W 49N050W
-CYQX0455 CYYR
-EET/EINN0026 EGGX0111 20W0136 CYQX0228 40W0330 50W0415 SEL/FJEL)
```

2.3.1.2.1 *Meaning*

Filed flight plan message — aircraft identification TPR101 — IFR, scheduled flight — a Boeing 707, medium wake turbulence category equipped with Loran C, HF RTF, VOR, Doppler, VHF RTF and SSR transponder with Modes A (4 096 code capability) and C — ADS capability — departure aerodrome is London, estimated off-block time 1400 UTC — cruising speed and requested flight level for the first portion of the route are 450 knots and FL 310 — the flight will proceed on Airways Green 1 and Upper Green 1 to a point bearing 285 degrees magnetic and 36 NM from the Strumble VOR. From this point the flight will fly at a constant Mach number of .82, proceeding on Upper Green 1 to 52N15W; then to 52N20W; to 52N30W; to 50N40W; to 49N50W; to destination Gander, total estimated elapsed time 4 hours and 55 minutes — alternate is Goose Bay — captain has notified accumulated estimated elapsed times at significant points along the route, they are at the Shannon FIR boundary 26 minutes, at the Shanwick Oceanic FIR boundary 1 hour and 11 minutes, at 20W 1 hour and 36 minutes, at the Gander Oceanic FIR boundary 2 hours and 28 minutes, at 40W 3 hours and 30 minutes and at 50W 4 hours and 15 minutes — SELCAL code is FJEL.

2.3.2 *Modification (CHG) message*

2.3.2.1 *Composition*

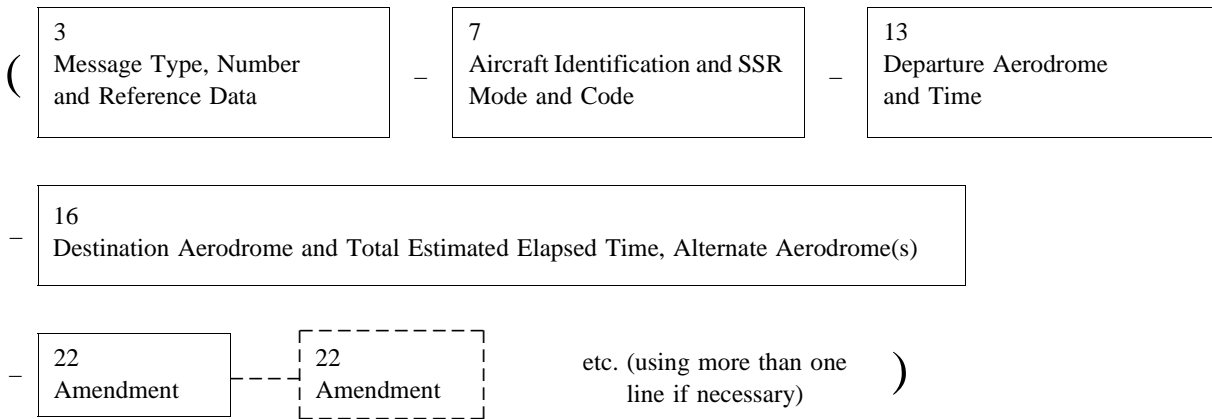

2.3.2.2 *Example*

The following is an example of a modification message sent by Amsterdam Centre to Frankfurt Centre correcting information previously sent to Frankfurt in a filed flight plan message. It is assumed that both centres are computer-equipped.

(CHGA/F016A/F014-GABWE/A2173-EHAM-EDDF-8/I-16/EDDN)

2.3.2.2.1 *Meaning*

Modification message — Amsterdam and Frankfurt computer unit identifiers A and F, followed by serial number (016) of this message sent by Amsterdam, repeat of computer unit identifiers followed by serial number (014) of the related filed flight plan message — aircraft identification GABWE, SSR Code 2173 operating in Mode A, en route from Amsterdam to Frankfurt — Field Type 8 of the related filed flight plan message is corrected to IFR — Field Type 16 of the related filed flight plan is corrected, the new destination is Nürnberg.

2.3.3 Flight plan cancellation (CNL) message

2.3.3.1 Composition

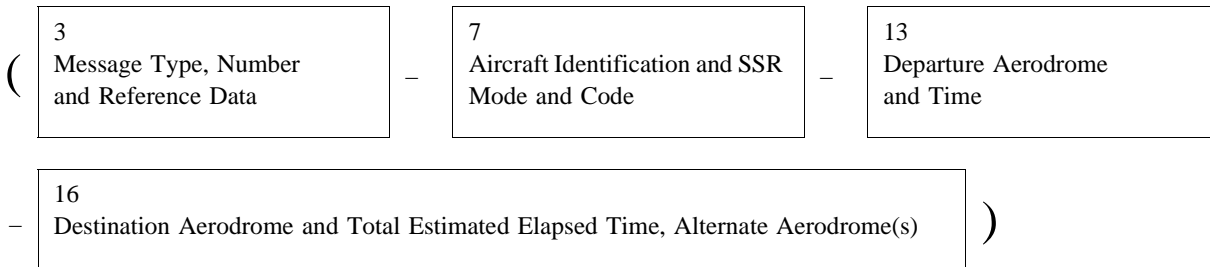

2.3.3.2 Example 1

The following is an example of a flight plan cancellation message sent by an ATS unit to all addressees of a filed flight plan message previously sent by that unit.

(CNL-DLH522-EDBB-LFPO)

2.3.3.2.1 Meaning

Flight plan cancellation message — cancel the flight plan of aircraft identification DLH522 — flight planned from Berlin to Paris.

2.3.3.3 Example 2

The following is an example of a flight plan cancellation message sent by a centre to an adjacent centre. It is assumed that both centres are equipped with ATC computers.

(CNLF/B127F/B055-BAW580-EDDF-EDDW)

2.3.3.3.1 Meaning

Flight plan cancellation message — identifiers of sending and receiving ATC computer units F and B, followed by serial number (127) of this message, repeat of computer unit identifiers followed by serial number (055) of current flight plan message previously transmitted — cancel the flight plan of aircraft identification BAW580 — flight planned from Frankfurt to Bremen.

2.3.4 Delay (DLA) message

2.3.4.1 Composition

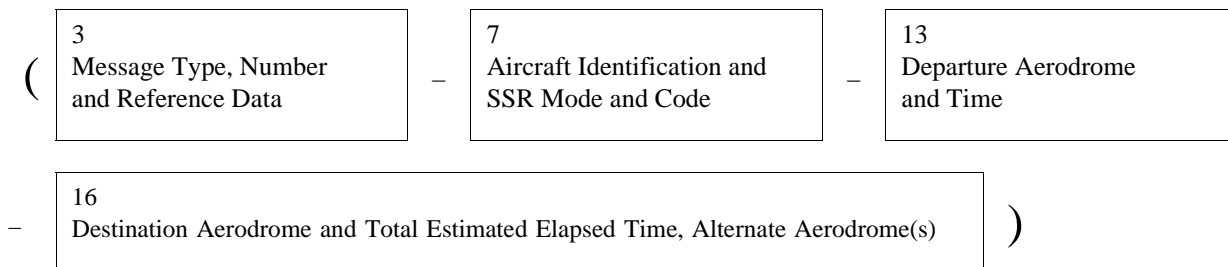

2.3.4.2 Example

The following is an example of a delay message sent from a departure aerodrome, or from a parent unit handling communications for a departure aerodrome, to each addressee of a filed flight plan message.

(DLA-KLM671-LIRF0900-LYDU)

2.3.4.2.1 Meaning

Delay message — aircraft identification KLM671 — revised estimated off-block time Fiumicino 0900 UTC destination Dubrovnik.

2.3.5 Departure (DEP) message

2.3.5.1 Composition

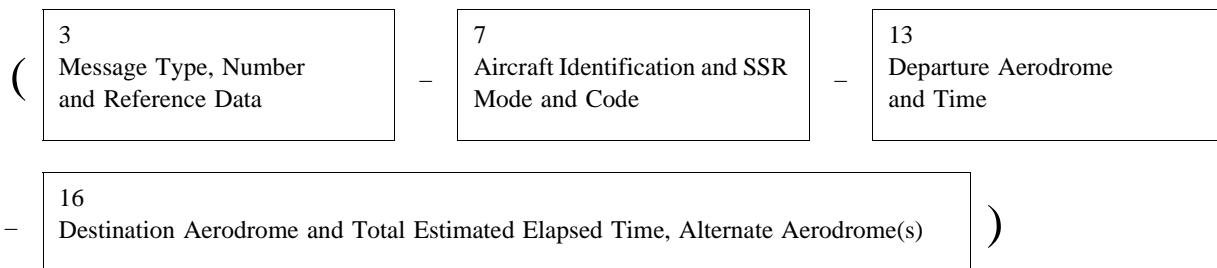

2.3.5.2 Example

The following is an example of a departure message sent from a departure aerodrome, or from a parent unit handling communications for a departure aerodrome, to each addressee of a filed flight plan message.

(DEP-CSA4311-EGPD1923-ENZV)

2.3.5.2.1 Meaning

Departure message — aircraft identification CSA4311 — departed from Aberdeen at 1923 UTC — destination Stavanger.

2.3.6 Arrival (ARR) message

2.3.6.1 Composition

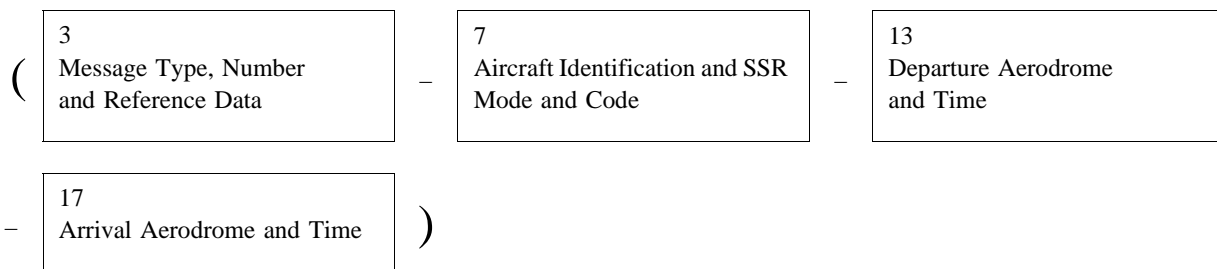

2.3.6.2 Example 1

The following is an example of an arrival message sent from the arrival aerodrome (= destination) to the departure aerodrome.

(ARR-CSA406-LHBP-LKPR0913)

2.3.6.2.1 Meaning

Arrival message — aircraft identification CSA406 — departed from Budapest/Ferihegy — landed at Prague/Ruzyne Airport at 0913 UTC.

2.3.6.3 Example 2

The following is an example of an arrival message sent for an aircraft which has landed at an aerodrome for which no ICAO location indicator has been allocated. The SSR Code would not be meaningful.

(ARR-HELI13-EHAM-ZZZZ1030 DEN HELDER)

2.3.6.3.1 Meaning

Arrival message aircraft identification HELI13 — departed from Amsterdam — landed at Den Helder heliport at 1030 UTC.

2.4 Co-ordination messages

2.4.1 Current flight plan (CPL) message

2.4.1.1 Composition

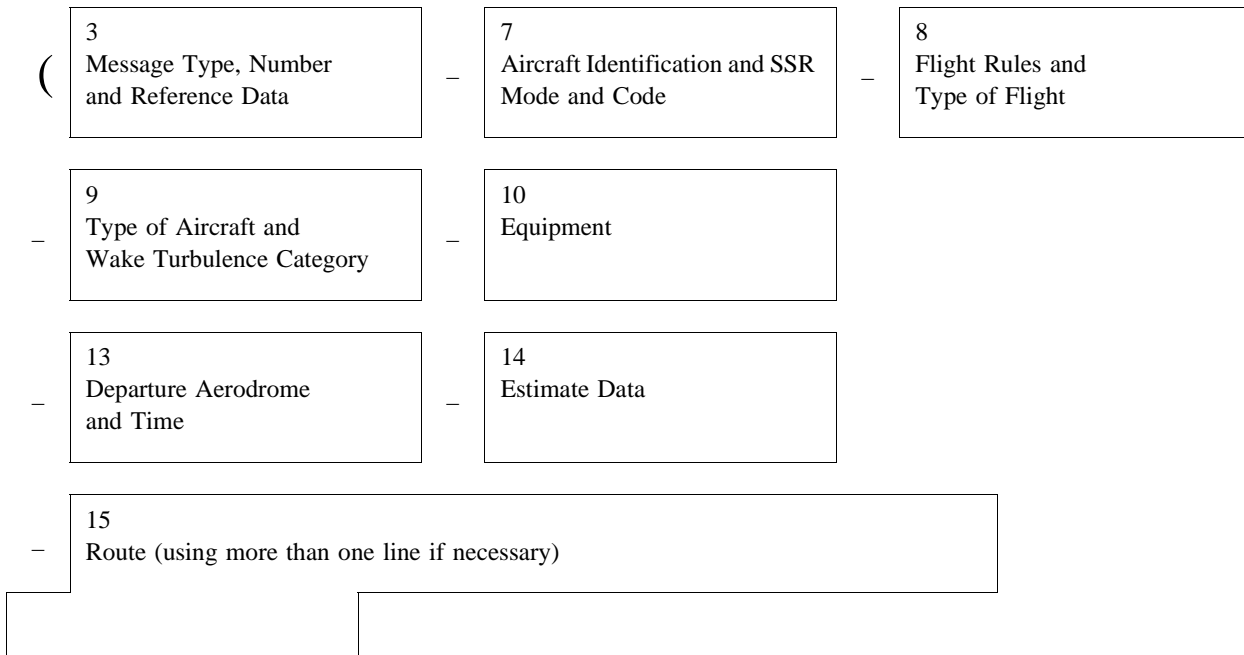

– 16
Destination Aerodrome and Total Estimated Elapsed Time, Alternate Aerodrome(s)

– 18
Other Information (using more than one line if necessary)

)

2.4.1.2 Example 1

The following is an example of a current flight plan message sent from Boston Centre to New York Centre on a flight which is en route from Boston to La Guardia Airport.

```
(CPL-UAL621/A5120-IS
-DC9/M-S/CD
-KBOS-HFD/1341A220A200A
-N0420A220 V3 AGL V445
-KLGA
-0)
```

2.4.1.3 Example 2

The following is an example of the same current flight plan message, but in this case the message is exchanged between ATC computers.

```
(CPLBOS/LGA052-UAL621/A5120-IS
-DC9/M-S/CD
-KBOS-HFD/1341A220A200A
-N0420A220 V3 AGL V445
-KLGA
-0)
```

Note.— The messages in Examples 1 and 2 are identical except that the Message Number of Example 2 does not appear in Example 1.

2.4.1.4 Meaning

Current flight plan message [with sending unit identity (BOS) and receiving unit identity (LGA), followed by the serial number of this message (052)] — aircraft identification UAL621, last assigned SSR Code 5120 in Mode A — IFR, scheduled flight — one DC9, medium wake turbulence category, equipped with standard communications, navigation and approach aid equipment for the route and SSR transponder with Modes A (4 096 code capability) and C — ADS capability — departed Boston — the flight is estimated to cross the Boston/New York “boundary” at point HFD at 1341 UTC, cleared by the Boston Centre at altitude 22 000 feet but to be at or above altitude 20 000 feet at HFD — TAS is 420 knots, requested cruising level is altitude 22 000 feet — the flight will proceed on airway V3 to reporting point AGL thence on airway V445 — destination is La Guardia Airport — no other information.

2.4.2 Estimate (EST) message

2.4.2.1 Composition

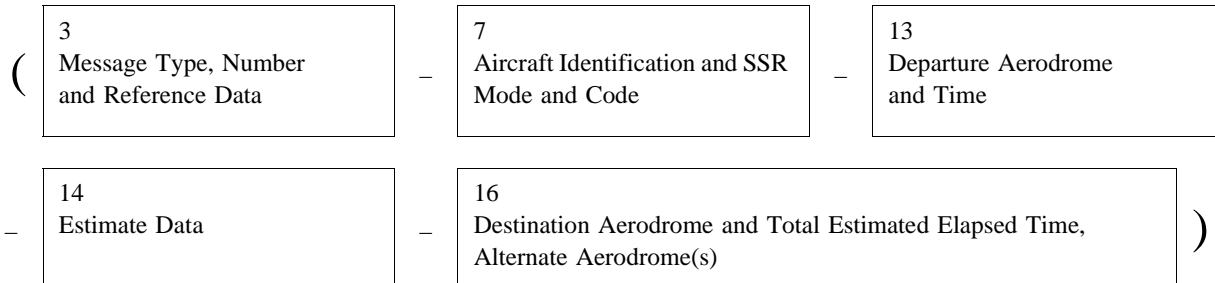

2.4.2.2 Example

The following is an example of an estimate message sent from Paris Centre to London Centre. It is assumed that London Centre has received a filed flight plan message relating to this flight. Both centres are equipped with computers.

(ESTP/L027-BAW671/A5631-LFPG-ABB/1548F140F110A-EGLL)

2.4.2.2.1 Meaning

Estimate message [with sending unit identity (P) and receiving unit identity (L), followed by the serial number of this message (027)] — aircraft identification BAW671, last assigned SSR Code 5631 operating in Mode A — departure aerodrome Paris de Gaulle — estimating Abbeville VOR 1548 UTC, cleared FL 140, flight will cross the Abbeville VOR at FL 110 or above, ascending — destination aerodrome London.

2.4.3 Co-ordination (CDN) message

2.4.3.1 Composition

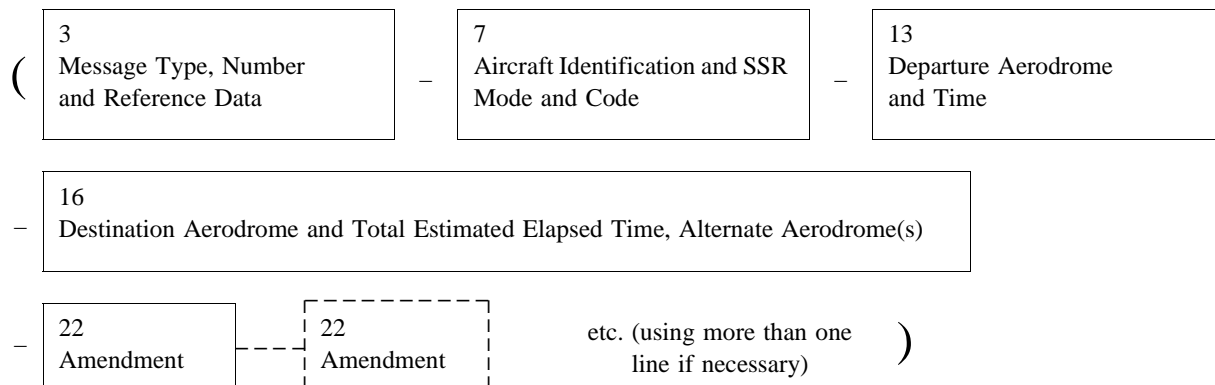

2.4.3.2 Example

The following is an example of a co-ordination message sent from Prestwick Centre to Dublin Centre proposing changes to the conditions under which an aircraft should cross the Dublin/Prestwick boundary. Prestwick has received a current flight plan message from Dublin and both centres are equipped with ATC computers.

(CDNP/D098D/P036-BAW617/A5136-EIDW-EGPK-14/GRN/1735F210F130A)

2.4.3.2.1 Meaning

Co-ordination message — Prestwick and Dublin ATC computer unit identifiers, P and D, followed by serial number (098) of this message sent by Prestwick, followed by analogous data identifying the current flight plan message sent from Dublin to which it is related (D/P036) — aircraft identification BAW617/SSR Code 5136 operating in Mode A — en route from Dublin to Prestwick — Field Type 14 is the subject of the proposal, i.e. Prestwick will accept the flight at the boundary point GRN at 1735 UTC and crossing the boundary point at or above FL 130 climbing to a cleared level of FL 210.

2.4.4 Acceptance (ACP) message

2.4.4.1 Composition

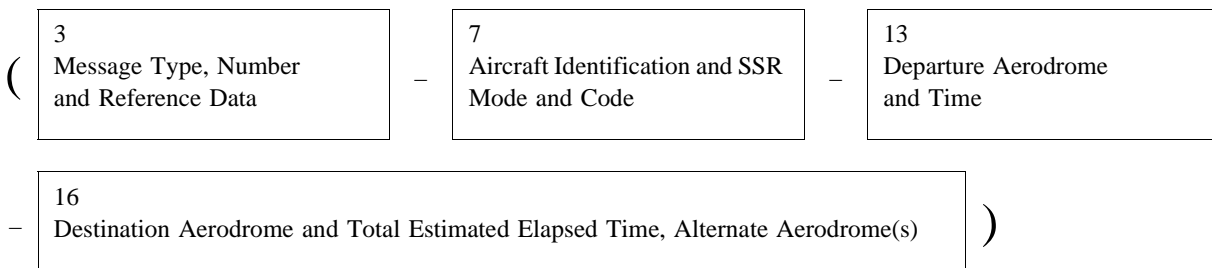

2.4.4.2 Example

The following is an example of an acceptance message sent from London Centre to Paris Centre relating to a current flight plan message which London has received from Paris. It is assumed that both centres are equipped with ATC computers.

(ACPL/P086P/L142-EIN065/A4570-LFPO-EGLL)

2.4.4.2.1 Meaning

Acceptance message — London and Paris computer unit identifiers, L and P, followed by serial number (086) of this message sent by London, followed by analogous data identifying the current flight plan message sent from Paris, to which it is related (PL142) — aircraft identification EIN065/SSR Code 4570 operating in Mode A — en route from Paris to London — is acceptable.

2.4.5 Logical acknowledgement (LAM) message

2.4.5.1 Composition

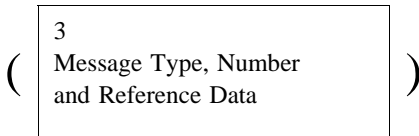

2.4.5.2 Example

The following is an example of a logical acknowledgement message sent by a centre to an adjacent centre reacting to a current flight plan message. It is assumed that both centres are equipped with ATC computers.

(LAMP/M178M/P100)

2.4.5.2.1 Meaning

Logical acknowledgement message — identifiers of sending and receiving ATC computer units Paris and Maastricht, followed by the sending unit serial number (178) of this message, followed by the computer unit identifiers and serial number (100) of the related estimate message.

2.5 Supplementary messages

2.5.1 Request flight plan (RQP) message

2.5.1.1 Composition

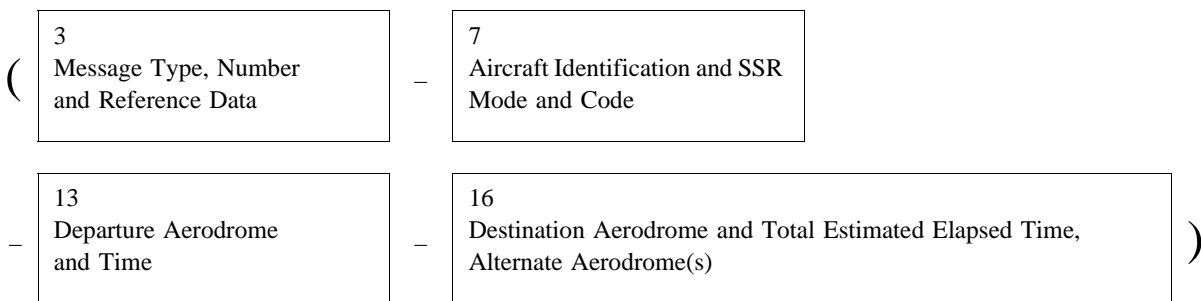

2.5.1.2 Example

The following is an example of a request flight plan message sent by a centre to an adjacent centre after receipt of an estimate message, for which no corresponding filed flight plan message had been received previously.

(RQP-PHOEN-EHRD-EDDL)

2.5.1.2.1 *Meaning*

Request flight plan message — aircraft identification PHOEN departed from Rotterdam — destination Düsseldorf.

2.5.2 *Request supplementary flight plan (RQS) message*

2.5.2.1 *Composition*

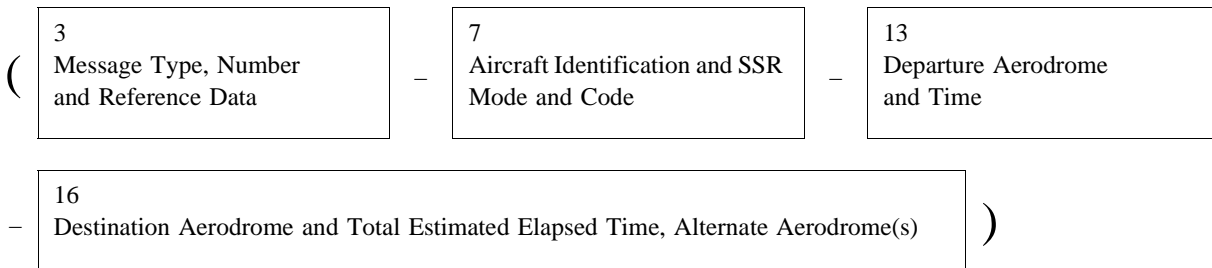

2.5.2.2 *Example*

The following is an example of a request supplementary flight plan message sent by an ATS unit to the ATS unit serving the departure aerodrome requesting information contained in the flight plan form, but not transmitted in the filed or current flight plan messages.

(RQS-KLM405/A4046-EHAM-CYMX)

2.5.2.2.1 *Meaning*

Request supplementary flight plan message — aircraft identification KLM405/SSR Code 4046 operating in Mode A — departure aerodrome is Amsterdam — destination aerodrome is Mirabel.

2.5.3 *Supplementary flight plan (SPL) message*

2.5.3.1 *Composition*

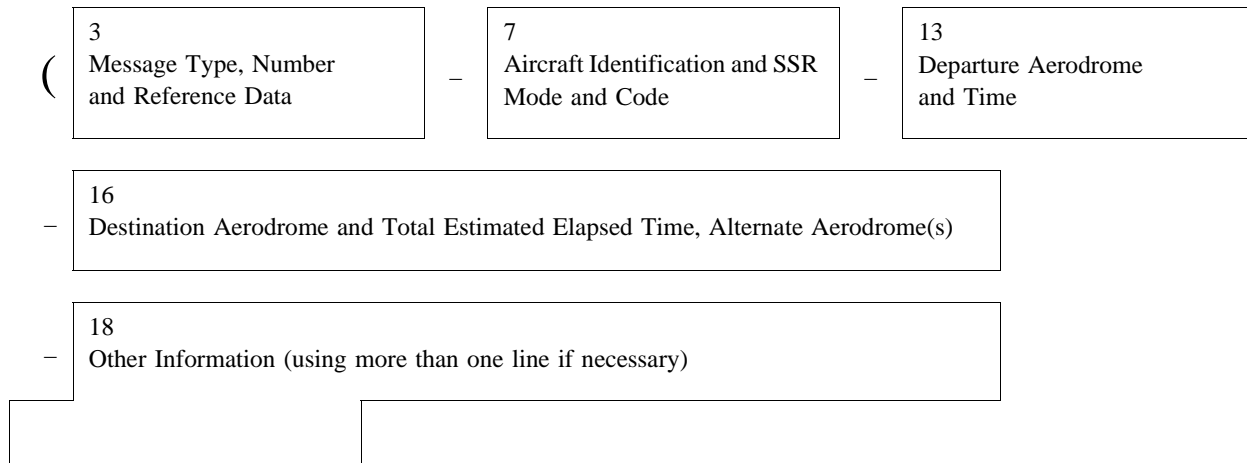

| | |
|----|---|
| 19 | Supplementary Information (using more than one line if necessary) |
|----|---|

)

2.5.3.2 Example

The following is an example of a supplementary flight plan message sent by the departure aerodrome of a flight to an ATS unit which had requested supplementary information recorded on the flight plan form (but not transmitted in filed flight plan messages or current flight plan messages).

(SPL-SAW502A
-EDDW0920
-EKCH0400 EKVB
-REG/GBZTA RMK/CHARTER
-E/0640 P/9 R/V J/L A/BLUE C/DENKE

2.5.3.2.1 Meaning

Supplementary flight plan message — aircraft identification SAW502A no SSR — departed Bremen 0920 UTC — destination Kastrup, total estimated elapsed time 4 hours — alternate Viborg — aircraft registration GBZTA — charter flight — endurance 6 hours and 40 minutes after departure — 9 persons on board — portable radio working on International Distress Frequency 121.5 MHz is carried — life jackets fitted with lights are carried — the aircraft colour is blue — the pilot's name is Denke.

APPENDIX 4. AIR TRAFFIC INCIDENT REPORT

1. ICAO model air traffic incident report form
2. Instructions for the completion of the air traffic incident report form

1. ICAO model air traffic incident report form

| AIR TRAFFIC INCIDENT REPORT FORM | | |
|--|--|-------------------------------------|
| <i>For use when submitting and receiving reports on air traffic incidents. In an initial report by radio, shaded items should be included.</i> | | |
| A — AIRCRAFT IDENTIFICATION | B — TYPE OF INCIDENT | |
| | AIRPROX / PROCEDURE / FACILITY* | |
| C — THE INCIDENT | | |
| 1. General | | |
| a) Date / time of incident _____ | UTC | |
| b) Position _____ | | |
| 2. Own aircraft | | |
| a) Heading and route _____ | | |
| b) True airspeed _____ measured in () kt _____ () km/h _____ | | |
| c) Level and altimeter setting | | |
| d) Aircraft climbing or descending | | |
| () Level flight | () Climbing | () Descending |
| e) Aircraft bank angle | | |
| () Wings level | () Slight bank | () Moderate bank |
| () Steep bank | () Inverted | () Unknown |
| f) Aircraft direction of bank | | |
| () Left | () Right | () Unknown |
| g) Restrictions to visibility (select as many as required) | | |
| () Sun glare | () Windscreen pillar | () Dirty windscreen |
| () Other cockpit structure | () None | |
| h) Use of aircraft lighting (select as many as required) | | |
| () Navigation lights | () Strobe lights | () Cabin lights |
| () Red anti-collision lights | () Landing / taxi lights | () Logo (tail fin) lights |
| () Other | () None | |
| i) Traffic avoidance advice issued by ATS | | |
| () Yes, based on radar | () Yes, based on visual sighting | () Yes, based on other information |
| () No | | |
| j) Traffic information issued | | |
| () Yes, based on radar | () Yes, based on visual sighting | () Yes, based on other information |
| () No | | |
| k) Airborne collision avoidance system — ACAS | | |
| () Not carried | () Type | () Traffic advisory issued |
| () Resolution advisory issued | () Traffic advisory or resolution advisory not issued | |

* Delete as appropriate

| | | |
|---|---|--|
| l) Radar identification | | |
| <input type="checkbox"/> No radar available | <input type="checkbox"/> Radar identification | <input type="checkbox"/> No radar identification |
| m) Other aircraft sighted | | |
| <input type="checkbox"/> Yes | <input type="checkbox"/> No | <input type="checkbox"/> Wrong aircraft sighted |
| n) Avoiding action taken | | |
| <input type="checkbox"/> Yes | <input type="checkbox"/> No | |
| o) Type of flight plan | IFR / VFR / none* | |

3. Other aircraft

a) Type and call sign / registration (if known) _____

b) If a) above not known, describe below

| | | |
|-------------------------------------|--|------------------------------------|
| <input type="checkbox"/> High wing | <input type="checkbox"/> Mid wing | <input type="checkbox"/> Low wing |
| <input type="checkbox"/> Rotorcraft | | |
| <input type="checkbox"/> 1 engine | <input type="checkbox"/> 2 engines | <input type="checkbox"/> 3 engines |
| <input type="checkbox"/> 4 engines | <input type="checkbox"/> More than 4 engines | |

Marking, colour or other available details

c) Aircraft climbing or descending

| | | |
|---------------------------------------|-----------------------------------|-------------------------------------|
| <input type="checkbox"/> Level flight | <input type="checkbox"/> Climbing | <input type="checkbox"/> Descending |
| <input type="checkbox"/> Unknown | | |

d) Aircraft bank angle

| | | |
|--------------------------------------|--------------------------------------|--|
| <input type="checkbox"/> Wings level | <input type="checkbox"/> Slight bank | <input type="checkbox"/> Moderate bank |
| <input type="checkbox"/> Steep bank | <input type="checkbox"/> Inverted | <input type="checkbox"/> Unknown |

e) Aircraft direction of bank

| | | |
|-------------------------------|--------------------------------|----------------------------------|
| <input type="checkbox"/> Left | <input type="checkbox"/> Right | <input type="checkbox"/> Unknown |
|-------------------------------|--------------------------------|----------------------------------|

f) Lights displayed

| | | |
|--|--|---|
| <input type="checkbox"/> Navigation lights | <input type="checkbox"/> Strobe lights | <input type="checkbox"/> Cabin lights |
| <input type="checkbox"/> Red anti-collision lights | <input type="checkbox"/> Landing / taxi lights | <input type="checkbox"/> Logo (tail fin) lights |
| <input type="checkbox"/> Other | <input type="checkbox"/> None | <input type="checkbox"/> Unknown |

g) Traffic avoidance advice issued by ATS

| | | |
|--|--|--|
| <input type="checkbox"/> Yes, based on radar | <input type="checkbox"/> Yes, based on visual sighting | <input type="checkbox"/> Yes, based on other information |
| <input type="checkbox"/> No | <input type="checkbox"/> Unknown | |

h) Traffic information issued

| | | |
|--|--|--|
| <input type="checkbox"/> Yes, based on radar | <input type="checkbox"/> Yes, based on visual sighting | <input type="checkbox"/> Yes, based on other information |
| <input type="checkbox"/> No | <input type="checkbox"/> Unknown | |

| | | |
|------------------------------|-----------------------------|----------------------------------|
| i) Avoiding action taken | | |
| <input type="checkbox"/> Yes | <input type="checkbox"/> No | <input type="checkbox"/> Unknown |

* Delete as appropriate

E — SUPPLEMENTARY INFORMATION BY ATS UNIT CONCERNED

1. Receipt of report

- a) Report received via AFTN / radio / telephone / other (specify)* _____
- b) Report received by _____ (name of ATS unit)

2. Details of ATS action

Clearance, incident seen (radar/visually, warning given, result of local enquiry, etc.)

DIAGRAMS OF AIRPROX

Mark passage of other aircraft relative to you, in plan on the left and in elevation on the right, assuming YOU are at the centre of each diagram. Include first sighting and passing distance.

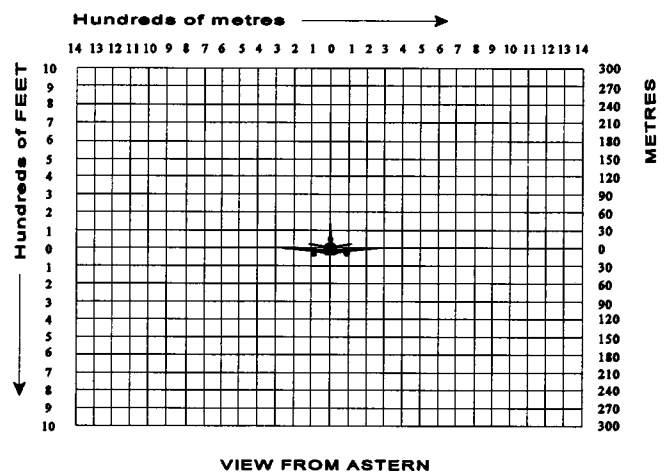
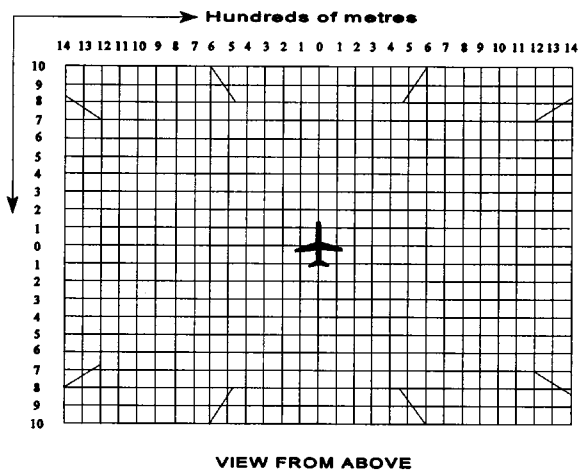

* Delete as appropriate

2. Instructions for the completion of the air traffic incident report form*Item*

- A Aircraft identification of the aircraft filing the report.
 - B An AIRPROX report should be filed immediately by radio.
 - C1 Date/time UTC and position in bearing and distance from a navigation aid or in LAT/LONG.
 - C2 Information regarding aircraft filing the report, tick as necessary.
 - C2 c) E.g. FL 350/1 013 hPa or 2 500 ft/QNH 1 007 hPa or 1 200 ft/QFE 998 hPa.
 - C3 Information regarding the other aircraft involved.
 - C4 Passing distance — state units used.
 - C6 Attach additional papers as required. The diagrams may be used to show aircraft's positions.
 - D1 f) State name of ATS unit and date/time in UTC.
 - D1 g) Date and time in UTC.
 - E2 Include details of ATS unit such as service provided, radiotelephony frequency, SSR Codes assigned and altimeter setting. Use diagram to show the aircraft's position and attach additional papers as required.
-

APPENDIX 5. CONTROLLER-PILOT DATA LINK COMMUNICATIONS (CPDLC) MESSAGE SET

1. Uplink messages
2. Downlink messages

1. Uplink messages

Table A5-1. Responses/acknowledgements (uplink)

| | <i>Message intent/use</i> | <i>Message element</i> | <i>URG</i> | <i>ALRT</i> | <i>RESP</i> |
|-----|--|--------------------------|------------|-------------|-------------|
| 0 | Indicates that ATC cannot comply with the request. | UNABLE | N | M | N |
| 1 | Indicates that ATC has received the message and will respond. | STANDBY | N | L | N |
| 2 | Indicates that ATC has received the request but it has been deferred until later. | REQUEST DEFERRED | N | L | N |
| 3 | Indicates that ATC has received and understood the message. | ROGER | N | L | N |
| 4 | Yes. | AFFIRM | N | L | N |
| 5 | No. | NEGATIVE | N | L | N |
| 235 | Notification of receipt of unlawful interference message. | ROGER 7500 | U | H | N |
| 211 | Indicates that ATC has received the request and has passed it to the next control authority. | REQUEST FORWARDED | N | L | N |
| 218 | Indicates to the pilot that the request has already been received on the ground. | REQUEST ALREADY RECEIVED | L | N | N |

Table A5-2. Vertical clearances (uplink)

| | <i>Message intent/use</i> | <i>Message element</i> | <i>URG</i> | <i>ALRT</i> | <i>RESP</i> |
|---|---|-------------------------------------|------------|-------------|-------------|
| 6 | Notification that a level change instruction should be expected. | EXPECT (<i>level</i>) | L | L | R |
| 7 | Notification that an instruction should be expected for the aircraft to commence climb at the specified time. | EXPECT CLIMB AT (<i>time</i>) | L | L | R |
| 8 | Notification that an instruction should be expected for the aircraft to commence climb at the specified position. | EXPECT CLIMB AT (<i>position</i>) | L | L | R |

| | <i>Message intent/use</i> | <i>Message element</i> | <i>URG</i> | <i>ALRT</i> | <i>RESP</i> |
|----|---|---|------------|-------------|-------------|
| 9 | Notification that an instruction should be expected for the aircraft to commence descent at the specified time. | EXPECT DESCENT AT <i>(time)</i> | L | L | R |
| 10 | Notification that an instruction should be expected for the aircraft to commence descent at the specified position. | EXPECT DESCENT AT <i>(position)</i> | L | L | R |
| 11 | Notification that an instruction should be expected for the aircraft to commence cruise climb at the specified time. | EXPECT CRUISE CLIMB AT <i>(time)</i> | L | L | R |
| 12 | Notification that an instruction should be expected for the aircraft to commence cruise climb at the specified position. | EXPECT CRUISE CLIMB AT <i>(position)</i> | L | L | R |
| 13 | Notification that an instruction should be expected for the aircraft to commence climb at the specified time to the specified level. | AT <i>(time)</i> EXPECT CLIMB TO <i>(level)</i> | L | L | R |
| 14 | Notification that an instruction should be expected for the aircraft to commence climb at the specified position to the specified level. | AT <i>(position)</i> EXPECT CLIMB TO <i>(level)</i> | L | L | R |
| 15 | Notification that an instruction should be expected for the aircraft to commence descent at the specified time to the specified level. | AT <i>(time)</i> EXPECT DESCENT TO <i>(level)</i> | L | L | R |
| 16 | Notification that an instruction should be expected for the aircraft to commence descent at the specified position to the specified level. | AT <i>(position)</i> EXPECT DESCENT TO <i>(level)</i> | L | L | R |
| 17 | Notification that an instruction should be expected for the aircraft to commence cruise climb at the specified time to the specified level. | AT <i>(time)</i> EXPECT CRUISE CLIMB TO <i>(level)</i> | L | L | R |
| 18 | Notification that an instruction should be expected for the aircraft to commence cruise climb at the specified position to the specified level. | AT <i>(position)</i> EXPECT CRUISE CLIMB TO <i>(level)</i> | L | L | R |
| 19 | Instruction to maintain the specified level. | MAINTAIN <i>(level)</i> | N | M | W/U |
| 20 | Instruction that a climb to a specified level is to commence and once reached the specified level is to be maintained. | CLIMB TO <i>(level)</i> | N | M | W/U |

| | <i>Message intent/use</i> | <i>Message element</i> | <i>URG</i> | <i>ALRT</i> | <i>RESP</i> |
|-----|---|---|------------|-------------|-------------|
| 21 | Instruction that at the specified time a climb to the specified level is to commence and once reached the specified level is to be maintained. | AT (<i>time</i>) CLIMB TO (<i>level</i>) | N | M | W/U |
| 22 | Instruction that at the specified position a climb to the specified level is to commence and once reached the specified level is to be maintained. | AT (<i>position</i>) CLIMB TO (<i>level</i>) | N | M | W/U |
| 185 | Instruction that after passing the specified position a climb to the specified level is to commence and once reached the specified level is to be maintained. | AFTER PASSING (<i>position</i>) CLIMB TO (<i>level</i>) | N | M | W/U |
| 23 | Instruction that a descent to a specified level is to commence and once reached the specified level is to be maintained. | DESCEND TO (<i>level</i>) | N | M | W/U |
| 24 | Instruction that at a specified time a descent to a specified level is to commence and once reached the specified level is to be maintained. | AT (<i>time</i>) DESCEND TO (<i>level</i>) | N | M | W/U |
| 25 | Instruction that at the specified position a descent to the specified level is to commence and once reached the specified level is to be maintained. | AT (<i>position</i>) DESCEND TO (<i>level</i>) | N | M | W/U |
| 186 | Instruction that after passing the specified position a descent to the specified level is to commence and once reached the specified level is to be maintained. | AFTER PASSING (<i>position</i>) DESCEND TO (<i>level</i>) | N | M | W/U |
| 26 | Instruction that a climb is to commence at a rate such that the specified level is reached at or before the specified time. | CLIMB TO REACH (<i>level</i>) BY (<i>time</i>) | N | M | W/U |
| 27 | Instruction that a climb is to commence at a rate such that the specified level is reached at or before the specified position. | CLIMB TO REACH (<i>level</i>) BY (<i>position</i>) | N | M | W/U |
| 28 | Instruction that a descent is to commence at a rate such that the specified level is reached at or before the specified time. | DESCEND TO REACH (<i>level</i>) BY (<i>time</i>) | N | M | W/U |
| 29 | Instruction that a descent is to commence at a rate such that the specified level is reached at or before the specified position. | DESCEND TO REACH (<i>level</i>) BY (<i>position</i>) | N | M | W/U |

| | <i>Message intent/use</i> | <i>Message element</i> | <i>URG</i> | <i>ALRT</i> | <i>RESP</i> |
|-----|--|--|------------|-------------|-------------|
| 192 | Instruction that a change of level is to continue, but at a rate such that the specified level is reached at or before the specified time. | REACH (<i>level</i>) BY (<i>time</i>) | N | M | W/U |
| 209 | Instruction that a change of level is to continue, but at a rate such that the specified level is reached at or before the specified position. | REACH (<i>level</i>) BY (<i>position</i>) | N | M | W/U |
| 30 | Instruction that a level within the defined vertical range specified is to be maintained. | MAINTAIN BLOCK (<i>level</i>) TO (<i>level</i>) | N | M | W/U |
| 31 | Instruction that a climb to a level within the vertical range defined is to commence. | CLIMB TO AND MAINTAIN BLOCK (<i>level</i>) TO (<i>level</i>) | N | M | W/U |
| 32 | Instruction that a descent to a level within the vertical range defined is to commence. | DESCEND TO AND MAINTAIN BLOCK (<i>level</i>) TO (<i>level</i>) | N | M | W/U |
| 34 | Instruction that a cruise climb is to commence and continue until the specified level is reached. | CRUISE CLIMB TO (<i>level</i>) | N | M | W/U |
| 35 | Instruction that a cruise climb can commence once above the specified level. | CRUISE CLIMB ABOVE (<i>level</i>) | N | M | W/U |
| 219 | Instruction to stop the climb below the previously assigned level. | STOP CLIMB AT (<i>level</i>) | U | M | W/U |
| 220 | Instruction to stop the descent above the previously assigned level. | STOP DESCENT AT (<i>level</i>) | U | M | W/U |
| 36 | Instruction that the climb to the specified level should be made at the aircraft's best rate. | EXPEDITE CLIMB TO (<i>level</i>) | U | M | W/U |
| 37 | Instruction that the descent to the specified level should be made at the aircraft's best rate. | EXPEDITE DESCENT TO (<i>level</i>) | U | M | W/U |
| 38 | Urgent instruction to immediately climb to the specified level. | IMMEDIATELY CLIMB TO (<i>level</i>) | D | H | W/U |
| 39 | Urgent instruction to immediately descend to the specified level. | IMMEDIATELY DESCEND TO (<i>level</i>) | D | H | W/U |
| 40 | (reserved) | | L | L | Y |
| 41 | (reserved) | | L | L | Y |
| 171 | Instruction to climb at not less than the specified rate. | CLIMB AT (<i>vertical rate</i>) MINIMUM | N | M | W/U |
| 172 | Instruction to climb at not above the specified rate. | CLIMB AT (<i>vertical rate</i>) MAXIMUM | N | M | W/U |
| 173 | Instruction to descend at not less than the specified rate. | DESCEND AT (<i>vertical rate</i>) MINIMUM | N | M | W/U |

| | <i>Message intent/use</i> | <i>Message element</i> | <i>URG</i> | <i>ALRT</i> | <i>RESP</i> |
|-----|---|--|------------|-------------|-------------|
| 174 | Instruction to descend at not above the specified rate. | DESCEND AT (<i>vertical rate</i>) MAXIMUM | N | M | W/U |
| 33 | (reserved) | | L | L | Y |

Note.— Wherever the variable “level” is specified, the message can specify either a single level or a vertical range, i.e. block level.

Table A5-3. Crossing constraints (uplink)

| | <i>Message intent/use</i> | <i>Message element</i> | <i>URG</i> | <i>ALRT</i> | <i>RESP</i> |
|----|--|---|------------|-------------|-------------|
| 42 | Notification that a level change instruction should be expected which will require the specified position to be crossed at the specified level. | EXPECT TO CROSS (<i>position</i>) AT (<i>level</i>) | L | L | R |
| 43 | Notification that a level change instruction should be expected which will require the specified position to be crossed at or above the specified level. | EXPECT TO CROSS (<i>position</i>) AT OR ABOVE (<i>level</i>) | L | L | R |
| 44 | Notification that a level change instruction should be expected which will require the specified position to be crossed at or below the specified level. | EXPECT TO CROSS (<i>position</i>) AT OR BELOW (<i>level</i>) | L | L | R |
| 45 | Notification that a level change instruction should be expected which will require the specified position to be crossed at the specified level which is to be maintained subsequently. | EXPECT TO CROSS (<i>position</i>) AT AND MAINTAIN (<i>level</i>) | L | L | R |
| 46 | Instruction that the specified position is to be crossed at the specified level. This may require the aircraft to modify its climb or descent profile. | CROSS (<i>position</i>) AT (<i>level</i>) | N | M | W/U |
| 47 | Instruction that the specified position is to be crossed at or above the specified level. | CROSS (<i>position</i>) AT OR ABOVE (<i>level</i>) | N | M | W/U |
| 48 | Instruction that the specified position is to be crossed at or below the specified level. | CROSS (<i>position</i>) AT OR BELOW (<i>level</i>) | N | M | W/U |
| 49 | Instruction that the specified position is to be crossed at the specified level and that level is to be maintained when reached. | CROSS (<i>position</i>) AT AND MAINTAIN (<i>level</i>) | N | M | W/U |
| 50 | Instruction that the specified position is to be crossed at a level between the specified levels. | CROSS (<i>position</i>) BETWEEN (<i>level</i>) AND (<i>level</i>) | N | M | W/U |

| | <i>Message intent/use</i> | <i>Message element</i> | <i>URG</i> | <i>ALRT</i> | <i>RESP</i> |
|----|--|--|------------|-------------|-------------|
| 51 | Instruction that the specified position is to be crossed at the specified time. | CROSS (<i>position</i>) AT (<i>time</i>) | N | M | W/U |
| 52 | Instruction that the specified position is to be crossed at or before the specified time. | CROSS (<i>position</i>) AT OR BEFORE (<i>time</i>) | N | M | W/U |
| 53 | Instruction that the specified position is to be crossed at or after the specified time. | CROSS (<i>position</i>) AT OR AFTER (<i>time</i>) | N | M | W/U |
| 54 | Instruction that the specified position is to be crossed at a time between the specified times. | CROSS (<i>position</i>) BETWEEN (<i>time</i>) AND (<i>time</i>) | N | M | W/U |
| 55 | Instruction that the specified position is to be crossed at the specified speed and the specified speed is to be maintained until further advised. | CROSS (<i>position</i>) AT (<i>speed</i>) | N | M | W/U |
| 56 | Instruction that the specified position is to be crossed at a speed equal to or less than the specified speed and the specified speed or less is to be maintained until further advised. | CROSS (<i>position</i>) AT OR LESS THAN (<i>speed</i>) | N | M | W/U |
| 57 | Instruction that the specified position is to be crossed at a speed equal to or greater than the specified speed and the specified speed or greater is to be maintained until further advised. | CROSS (<i>position</i>) AT OR GREATER THAN (<i>speed</i>) | N | M | W/U |
| 58 | Instruction that the specified position is to be crossed at the specified time and at the specified level. | CROSS (<i>position</i>) AT (<i>time</i>) AT (<i>level</i>) | N | M | W/U |
| 59 | Instruction that the specified position is to be crossed at or before the specified time and at the specified level. | CROSS (<i>position</i>) AT OR BEFORE (<i>time</i>) AT (<i>level</i>) | N | M | W/U |
| 60 | Instruction that the specified position is to be crossed at or after the specified time and at the specified level. | CROSS (<i>position</i>) AT OR AFTER (<i>time</i>) AT (<i>level</i>) | N | M | W/U |
| 61 | Instruction that the specified position is to be crossed at the specified level and speed, and the level and speed are to be maintained. | CROSS (<i>position</i>) AT AND MAINTAIN (<i>level</i>) AT (<i>speed</i>) | N | M | W/U |
| 62 | Instruction that at the specified time the specified position is to be crossed at the specified level and the level is to be maintained. | AT (<i>time</i>) CROSS (<i>position</i>) AT AND MAINTAIN (<i>level</i>) | N | M | W/U |

| | <i>Message intent/use</i> | <i>Message element</i> | <i>URG</i> | <i>ALRT</i> | <i>RESP</i> |
|----|--|---|------------|-------------|-------------|
| 63 | Instruction that at the specified time the specified position is to be crossed at the specified level and speed, and the level and speed are to be maintained. | AT (<i>time</i>) CROSS (<i>position</i>) AT AND MAINTAIN (<i>level</i>) AT (<i>speed</i>) | N | M | W/U |

Note.— Wherever the variable “level” is specified, the message can specify either a single level or a vertical range, i.e. block level.

Table A5-4. Lateral offsets (uplink)

| | <i>Message intent/use</i> | <i>Message element</i> | <i>URG</i> | <i>ALRT</i> | <i>RESP</i> |
|----|--|---|------------|-------------|-------------|
| 64 | Instruction to fly a parallel track to the cleared route at a displacement of the specified distance in the specified direction. | OFFSET (<i>specified distance</i>) (<i>direction</i>) OF ROUTE | N | M | W/U |
| 65 | Instruction to fly a parallel track to the cleared route at a displacement of the specified distance in the specified direction and commencing at the specified position. | AT (<i>position</i>) OFFSET (<i>specified distance</i>) (<i>direction</i>) OF ROUTE | N | M | W/U |
| 66 | Instruction to fly a parallel track to the cleared route at a displacement of the specified distance in the specified direction and commencing at the specified time. | AT (<i>time</i>) OFFSET (<i>specified distance</i>) (<i>direction</i>) OF ROUTE | N | M | W/U |
| 67 | Instruction that the cleared flight route is to be rejoined. | PROCEED BACK ON ROUTE | N | M | W/U |
| 68 | Instruction that the cleared flight route is to be rejoined at or before the specified position. | REJOIN ROUTE BY (<i>position</i>) | N | M | W/U |
| 69 | Instruction that the cleared flight route is to be rejoined at or before the specified time. | REJOIN ROUTE BY (<i>time</i>) | N | M | W/U |
| 70 | Notification that a clearance may be issued to enable the aircraft to rejoin the cleared route at or before the specified position. | EXPECT BACK ON ROUTE BY (<i>position</i>) | L | L | R |
| 71 | Notification that a clearance may be issued to enable the aircraft to rejoin the cleared route at or before the specified time. | EXPECT BACK ON ROUTE BY (<i>time</i>) | L | L | R |
| 72 | Instruction to resume own navigation following a period of tracking or heading clearances. May be used in conjunction with an instruction on how or where to rejoin the cleared route. | RESUME OWN NAVIGATION | N | M | W/U |

Table A5-5. Route modifications (uplink)

| | <i>Message intent/use</i> | <i>Message element</i> | <i>URG</i> | <i>ALRT</i> | <i>RESP</i> |
|-----|---|--|------------|-------------|-------------|
| 73 | Notification to the aircraft of the instructions to be followed from departure until the specified clearance limit. | <i>(departure clearance)</i> | N | M | W/U |
| 74 | Instruction to proceed directly from its present position to the specified position. | PROCEED DIRECT TO <i>(position)</i> | N | M | W/U |
| 75 | Instruction to proceed, when able, directly to the specified position. | WHEN ABLE PROCEED DIRECT TO <i>(position)</i> | N | M | W/U |
| 76 | Instruction to proceed, at the specified time, directly to the specified position. | AT <i>(time)</i> PROCEED DIRECT TO <i>(position)</i> | N | M | W/U |
| 77 | Instruction to proceed, at the specified position, directly to the next specified position. | AT <i>(position)</i> PROCEED DIRECT TO <i>(position)</i> | N | M | W/U |
| 78 | Instruction to proceed, upon reaching the specified level, directly to the specified position. | AT <i>(level)</i> PROCEED DIRECT TO <i>(position)</i> | N | M | W/U |
| 79 | Instruction to proceed to the specified position via the specified route. | CLEARED TO <i>(position)</i> VIA <i>(route clearance)</i> | N | M | W/U |
| 80 | Instruction to proceed via the specified route. | CLEARED <i>(route clearance)</i> | N | M | W/U |
| 81 | Instruction to proceed in accordance with the specified procedure. | CLEARED <i>(procedure name)</i> | N | M | W/U |
| 236 | Instruction to leave controlled airspace. | LEAVE CONTROLLED AIRSPACE | N | M | W/U |
| 82 | Approval to deviate up to the specified distance from the cleared route in the specified direction. | CLEARED TO DEVIATE UP TO <i>(specified distance)</i> <i>(direction)</i> OF ROUTE | N | M | W/U |
| 83 | Instruction to proceed from the specified position via the specified route. | AT <i>(position)</i> CLEARED <i>(route clearance)</i> | N | M | W/U |
| 84 | Instruction to proceed from the specified position via the specified procedure. | AT <i>(position)</i> CLEARED <i>(procedure name)</i> | N | M | W/U |
| 85 | Notification that a clearance to fly on the specified route may be issued. | EXPECT <i>(route clearance)</i> | L | L | R |
| 86 | Notification that a clearance to fly on the specified route from the specified position may be issued. | AT <i>(position)</i> EXPECT <i>(route clearance)</i> | L | L | R |
| 87 | Notification that a clearance to fly directly to the specified position may be issued. | EXPECT DIRECT TO <i>(position)</i> | L | L | R |

| | <i>Message intent/use</i> | <i>Message element</i> | <i>URG</i> | <i>ALRT</i> | <i>RESP</i> |
|-----|---|---|------------|-------------|-------------|
| 88 | Notification that a clearance to fly directly from the first specified position to the next specified position may be issued. | AT (<i>position</i>) EXPECT DIRECT TO (<i>position</i>) | L | L | R |
| 89 | Notification that a clearance to fly directly to the specified position commencing at the specified time may be issued. | AT (<i>time</i>) EXPECT DIRECT TO (<i>position</i>) | L | L | R |
| 90 | Notification that a clearance to fly directly to the specified position commencing when the specified level is reached may be issued. | AT (<i>level</i>) EXPECT DIRECT TO (<i>position</i>) | L | L | R |
| 91 | Instruction to enter a holding pattern with the specified characteristics at the specified position and level. | HOLD AT (<i>position</i>) MAINTAIN (<i>level</i>) INBOUND TRACK (<i>degrees</i>) (<i>direction</i>) TURNS (<i>leg type</i>) | N | M | W/U |
| 92 | Instruction to enter a holding pattern with the published characteristics at the specified position and level. | HOLD AT (<i>position</i>) AS PUBLISHED MAINTAIN (<i>level</i>) | N | M | W/U |
| 93 | Notification that an onwards clearance may be issued at the specified time. | EXPECT FURTHER CLEARANCE AT (<i>time</i>) | L | L | R |
| 94 | Instruction to turn left or right as specified on to the specified heading. | TURN (<i>direction</i>) HEADING (<i>degrees</i>) | N | M | W/U |
| 95 | Instruction to turn left or right as specified on to the specified track. | TURN (<i>direction</i>) GROUND TRACK (<i>degrees</i>) | N | M | W/U |
| 215 | Instruction to turn a specified number of degrees left or right. | TURN (<i>direction</i>) (<i>degrees</i>) | N | M | W/U |
| 190 | Instruction to fly on the specified heading. | FLY HEADING (<i>degrees</i>) | N | M | W/U |
| 96 | Instruction to continue to fly on the current heading. | CONTINUE PRESENT HEADING | N | M | W/U |
| 97 | Instruction to fly on the specified heading from the specified position. | AT (<i>position</i>) FLY HEADING (<i>degrees</i>) | N | M | W/U |
| 221 | Instruction to stop turn at the specified heading prior to reaching the previously assigned heading. | STOP TURN HEADING (<i>degrees</i>) | U | M | W/U |
| 98 | Instruction to turn immediately left or right as specified on to the specified heading. | IMMEDIATELY TURN (<i>direction</i>) HEADING (<i>degrees</i>) | D | H | W/U |
| 99 | Notification that a clearance may be issued for the aircraft to fly the specified procedure. | EXPECT (<i>procedure name</i>) | L | L | R |

Note.— Wherever the variable “level” is specified, the message can specify either a single level or a vertical range, i.e. block level.

Table A5-6. Speed changes (uplink)

| | <i>Message intent/use</i> | <i>Message element</i> | <i>URG</i> | <i>ALRT</i> | <i>RESP</i> |
|-----|--|---|------------|-------------|-------------|
| 100 | Notification that a speed instruction may be issued to be effective at the specified time. | AT (<i>time</i>) EXPECT (<i>speed</i>) | L | L | R |
| 101 | Notification that a speed instruction may be issued to be effective at the specified position. | AT (<i>position</i>) EXPECT (<i>speed</i>) | L | L | R |
| 102 | Notification that a speed instruction may be issued to be effective at the specified level. | AT (<i>level</i>) EXPECT (<i>speed</i>) | L | L | R |
| 103 | Notification that a speed range instruction may be issued to be effective at the specified time. | AT (<i>time</i>) EXPECT (<i>speed</i>) TO (<i>speed</i>) | L | L | R |
| 104 | Notification that a speed range instruction may be issued to be effective at the specified position. | AT (<i>position</i>) EXPECT (<i>speed</i>) TO (<i>speed</i>) | L | L | R |
| 105 | Notification that a speed range instruction may be issued to be effective at the specified level. | AT (<i>level</i>) EXPECT (<i>speed</i>) TO (<i>speed</i>) | L | L | R |
| 106 | Instruction that the specified speed is to be maintained. | MAINTAIN (<i>speed</i>) | N | M | W/U |
| 188 | Instruction that after passing the specified position the specified speed is to be maintained. | AFTER PASSING (<i>position</i>) MAINTAIN (<i>speed</i>) | N | M | W/U |
| 107 | Instruction that the present speed is to be maintained. | MAINTAIN PRESENT SPEED | N | M | W/U |
| 108 | Instruction that the specified speed or a greater speed is to be maintained. | MAINTAIN (<i>speed</i>) OR GREATER | N | M | W/U |
| 109 | Instruction that the specified speed or a lesser speed is to be maintained. | MAINTAIN (<i>speed</i>) OR LESS | N | M | W/U |
| 110 | Instruction that a speed within the specified range is to be maintained. | MAINTAIN (<i>speed</i>) TO (<i>speed</i>) | N | M | W/U |
| 111 | Instruction that the present speed is to be increased to the specified speed and maintained until further advised. | INCREASE SPEED TO (<i>speed</i>) | N | M | W/U |
| 112 | Instruction that the present speed is to be increased to the specified speed or greater, and maintained at or above the specified speed until further advised. | INCREASE SPEED TO (<i>speed</i>) OR GREATER | N | M | W/U |
| 113 | Instruction that the present speed is to be reduced to the specified speed and maintained until further advised. | REDUCE SPEED TO (<i>speed</i>) | N | M | W/U |
| 114 | Instruction that the present speed is to be reduced to the specified speed or less and maintained at or below the specified speed until further advised. | REDUCE SPEED TO (<i>speed</i>) OR LESS | N | M | W/U |

| | <i>Message intent/use</i> | <i>Message element</i> | <i>URG</i> | <i>ALRT</i> | <i>RESP</i> |
|-----|--|----------------------------------|------------|-------------|-------------|
| 115 | Instruction that the specified speed is not to be exceeded. | DO NOT EXCEED (<i>speed</i>) | N | M | W/U |
| 116 | Notification that the aircraft need no longer comply with the previously issued speed restriction. | RESUME NORMAL SPEED | N | M | W/U |
| 189 | Instruction that the present speed is to be changed to the specified speed. | ADJUST SPEED TO (<i>speed</i>) | N | M | W/U |
| 222 | Notification that the aircraft may keep its preferred speed without restriction. | NO SPEED RESTRICTION | L | L | R |
| 223 | Instruction to reduce present speed to the minimum safe approach speed | REDUCE TO MINIMUM APPROACH SPEED | N | M | W/U |

Note.— Wherever the variable “level” is specified, the message can specify either a single level or a vertical range, i.e. block level.

Table A5-7. Contact/monitor/surveillance requests (uplink)

| | <i>Message intent/use</i> | <i>Message element</i> | <i>URG</i> | <i>ALRT</i> | <i>RESP</i> |
|-----|---|--|------------|-------------|-------------|
| 117 | Instruction that the ATS unit with the specified ATS unit name is to be contacted on the specified frequency. | CONTACT (<i>unit name</i>) (<i>frequency</i>) | N | M | W/U |
| 118 | Instruction that at the specified position the ATS unit with the specified ATS unit name is to be contacted on the specified frequency. | AT (<i>position</i>) CONTACT (<i>unit name</i>) (<i>frequency</i>) | N | M | W/U |
| 119 | Instruction that at the specified time the ATS unit with the specified ATS unit name is to be contacted on the specified frequency. | AT (<i>time</i>) CONTACT (<i>unit name</i>) (<i>frequency</i>) | N | M | W/U |
| 120 | Instruction that the ATS unit with the specified ATS unit name is to be monitored on the specified frequency. | MONITOR (<i>unit name</i>) (<i>frequency</i>) | N | M | W/U |
| 121 | Instruction that at the specified position the ATS unit with the specified ATS unit name is to be monitored on the specified frequency. | AT (<i>position</i>) MONITOR (<i>unit name</i>) (<i>frequency</i>) | N | M | W/U |
| 122 | Instruction that at the specified time the ATS unit with the specified ATS unit name is to be monitored on the specified frequency. | AT (<i>time</i>) MONITOR (<i>unit name</i>) (<i>frequency</i>) | N | M | W/U |

| | <i>Message intent/use</i> | <i>Message element</i> | <i>URG</i> | <i>ALRT</i> | <i>RESP</i> |
|-----|--|--------------------------|------------|-------------|-------------|
| 123 | Instruction that the specified code (SSR code) is to be selected. | SQUAWK (<i>code</i>) | N | M | W/U |
| 124 | Instruction that the SSR transponder responses are to be disabled. | STOP SQUAWK | N | M | W/U |
| 125 | Instruction that the SSR transponder responses should include level information. | SQUAWK MODE CHARLIE | N | M | W/U |
| 126 | Instruction that the SSR transponder responses should no longer include level information. | STOP SQUAWK MODE CHARLIE | N | M | W/U |
| 179 | Instruction that the 'ident' function on the SSR transponder is to be actuated. | SQUAWK IDENT | N | M | W/U |

Table A5-8. Report/confirmation requests (uplink)

| | <i>Message intent/use</i> | <i>Message element</i> | <i>URG</i> | <i>ALRT</i> | <i>RESP</i> |
|-----|---|---|------------|-------------|-------------|
| 127 | Instruction to report when the aircraft is back on the cleared route. | REPORT BACK ON ROUTE | N | L | W/U |
| 128 | Instruction to report when the aircraft has left the specified level. | REPORT LEAVING (<i>level</i>) | N | L | W/U |
| 129 | Instruction to report when the aircraft is maintaining level flight at the specified level. | REPORT MAINTAINING (<i>level</i>) | N | L | W/U |
| 175 | Instruction to report when the aircraft has reached the specified level. | REPORT REACHING (<i>level</i>) | N | L | W/U |
| 200 | Instruction used in conjunction with a level clearance to report reaching the level assigned. | REPORT REACHING | N | L | W/U |
| 180 | Instruction to report when the aircraft is within the specified vertical range. | REPORT REACHING BLOCK (<i>level</i>) TO (<i>level</i>) | N | L | W/U |
| 130 | Instruction to report when the aircraft has passed the specified position. | REPORT PASSING (<i>position</i>) | N | L | W/U |
| 181 | Instruction to report the present distance to or from the specified position. | REPORT DISTANCE (<i>to/from</i>) (<i>position</i>) | N | M | Y |
| 184 | Instruction to report at the specified time the distance to or from the specified position. | AT (<i>time</i>) REPORT DISTANCE (<i>to/from</i>) (<i>position</i>) | N | L | Y |

| | <i>Message intent/use</i> | <i>Message element</i> | <i>URG</i> | <i>ALRT</i> | <i>RESP</i> |
|-----|--|--|------------|-------------|-------------|
| 228 | Instruction to report the estimated time of arrival at the specified position. | REPORT ETA (<i>position</i>) | L | L | Y |
| 131 | Instruction to report the amount of fuel remaining and the number of persons on board. | REPORT REMAINING FUEL AND PERSONS ON BOARD | U | M | Y |
| 132 | Instruction to report the present position. | REPORT POSITION | N | M | Y |
| 133 | Instruction to report the present level. | REPORT PRESENT LEVEL | N | M | Y |
| 134 | Instruction to report the requested speed. | REPORT (<i>speed type</i>) (<i>speed type</i>) (<i>speed type</i>) SPEED | N | M | Y |
| 135 | Instruction to confirm and acknowledge the currently assigned level. | CONFIRM ASSIGNED LEVEL | N | L | Y |
| 136 | Instruction to confirm and acknowledge the currently assigned speed. | CONFIRM ASSIGNED SPEED | N | L | Y |
| 137 | Instruction to confirm and acknowledge the currently assigned route. | CONFIRM ASSIGNED ROUTE | N | L | Y |
| 138 | Instruction to confirm the previously reported time over the last reported waypoint. | CONFIRM TIME OVER REPORTED WAYPOINT | N | L | Y |
| 139 | Instruction to confirm the identity of the previously reported waypoint. | CONFIRM REPORTED WAYPOINT | N | L | Y |
| 140 | Instruction to confirm the identity of the next waypoint. | CONFIRM NEXT WAYPOINT | N | L | Y |
| 141 | Instruction to confirm the previously reported estimated time at the next waypoint. | CONFIRM NEXT WAYPOINT ETA | N | L | Y |
| 142 | Instruction to confirm the identity of the next but one waypoint. | CONFIRM ENSUING WAYPOINT | N | L | Y |
| 143 | The request was not understood. It should be clarified and resubmitted. | CONFIRM REQUEST | N | L | Y |
| 144 | Instruction to report the selected (SSR) code. | CONFIRM SQUAWK | N | L | Y |
| 145 | Instruction to report the present heading. | REPORT HEADING | N | M | Y |
| 146 | Instruction to report the present ground track. | REPORT GROUND TRACK | N | M | Y |
| 182 | Instruction to report the identification code of the last ATIS received. | CONFIRM ATIS CODE | N | L | Y |
| 147 | Instruction to make a position report. | REQUEST POSITION REPORT | N | M | Y |

| | <i>Message intent/use</i> | <i>Message element</i> | <i>URG</i> | <i>ALRT</i> | <i>RESP</i> |
|-----|--|----------------------------|------------|-------------|-------------|
| 216 | Instruction to file a flight plan. | REQUEST FLIGHT PLAN | N | M | Y |
| 217 | Instruction to report that the aircraft has landed. | REPORT ARRIVAL | N | M | Y |
| 229 | Instruction to report the preferred alternate aerodrome for landing. | REPORT ALTERNATE AERODROME | L | L | Y |
| 231 | Instruction to indicate the pilot's preferred level. | STATE PREFERRED LEVEL | L | L | Y |
| 232 | Instruction to indicate the pilot's preferred time and/or position to commence descent to the aerodrome of intended arrival. | STATE TOP OF DESCENT | L | L | Y |

Note.— Wherever the variable “level” is specified, the message can specify either a single level or a vertical range, i.e. block level.

Table A5-9. Negotiation requests (uplink)

| | <i>Message intent/use</i> | <i>Message element</i> | <i>URG</i> | <i>ALRT</i> | <i>RESP</i> |
|-----|---|--|------------|-------------|-------------|
| 148 | Request for the earliest time at which the specified level can be accepted. | WHEN CAN YOU ACCEPT (<i>level</i>) | N | L | Y |
| 149 | Instruction to report whether or not the specified level can be accepted at the specified position. | CAN YOU ACCEPT (<i>level</i>) AT (<i>position</i>) | N | L | A/N |
| 150 | Instruction to report whether or not the specified level can be accepted at the specified time. | CAN YOU ACCEPT (<i>level</i>) AT (<i>time</i>) | N | L | A/N |
| 151 | Instruction to report the earliest time when the specified speed can be accepted. | WHEN CAN YOU ACCEPT (<i>speed</i>) | N | L | Y |
| 152 | Instruction to report the earliest time when the specified offset track can be accepted. | WHEN CAN YOU ACCEPT (<i>specified distance</i>) (<i>direction</i>) OFFSET | N | L | Y |

Note.— Wherever the variable “level” is specified, the message can specify either a single level or a vertical range, i.e. block level.

Table A5-10. Air traffic advisories (uplink)

| | <i>Message intent/use</i> | <i>Message element</i> | <i>URG</i> | <i>ALRT</i> | <i>RESP</i> |
|-----|--|---|------------|-------------|-------------|
| 153 | ATS advisory that the altimeter setting should be the specified setting. | ALTIMETER (<i>altimeter</i>) | N | L | R |
| 213 | ATS advisory that the specified altimeter setting relates to the specified facility. | (<i>facility designation</i>) ALTIMETER (<i>altimeter</i>) | N | L | R |

| | <i>Message intent/use</i> | <i>Message element</i> | <i>URG</i> | <i>ALRT</i> | <i>RESP</i> |
|-----|---|--|------------|-------------|-------------|
| 154 | ATS advisory that the radar service is terminated. | RADAR SERVICE TERMINATED | N | L | R |
| 191 | ATS advisory that the aircraft is entering airspace in which no air traffic services are provided and all existing air traffic services are terminated. | ALL ATS TERMINATED | N | M | R |
| 155 | ATS advisory that radar contact has been established at the specified position. | RADAR CONTACT (<i>position</i>) | N | M | R |
| 156 | ATS advisory that radar contact has been lost. | RADAR CONTACT LOST | N | M | R |
| 210 | ATS advisory that the aircraft has been identified on radar at the specified position. | IDENTIFIED (<i>position</i>) | N | M | R |
| 193 | Notification that radar identification has been lost. | IDENTIFICATION LOST | N | M | R |
| 157 | Notification that a continuous transmission is detected on the specified frequency. Check the microphone button. | CHECK STUCK MICROPHONE (<i>frequency</i>) | U | M | N |
| 158 | ATS advisory that the ATIS information identified by the specified code is the current ATIS information. | ATIS (<i>atis code</i>) | N | L | R |
| 212 | ATS advisory that the specified ATIS information at the specified airport is current. | (<i>facility designation</i>) ATIS (<i>atis code</i>) CURRENT | N | L | R |
| 214 | ATS advisory that indicates the RVR value for the specified runway. | RVR RUNWAY (<i>runway</i>) (<i>rvr</i>) | N | M | R |
| 224 | ATS advisory that no delay is expected. | NO DELAY EXPECTED | N | L | R |
| 225 | ATS advisory that the expected delay has not been determined. | DELAY NOT DETERMINED | N | L | R |
| 226 | ATS advisory that the aircraft may expect to be cleared to commence its approach procedure at the specified time. | EXPECTED APPROACH TIME (<i>time</i>) | N | L | R |

Table A5-11. System management messages (uplink)

| | <i>Message intent/use</i> | <i>Message element</i> | <i>URG</i> | <i>ALRT</i> | <i>RESP</i> |
|-----|--|---|------------|-------------|-------------|
| 159 | A system-generated message notifying that the ground system has detected an error. | ERROR (<i>error information</i>) | U | M | N |
| 160 | Notification to the avionics that the specified data authority is the next data authority. If no data authority is specified, this indicates that any previously specified next data authority is no longer valid. | NEXT DATA AUTHORITY (<i>facility</i>) | L | N | N |
| 161 | Notification to the avionics that the data link connection with the current data authority is being terminated. | END SERVICE | L | N | N |
| 162 | Notification that the ground system does not support this message. | SERVICE UNAVAILABLE | L | L | N |
| 234 | Notification that the ground system does not have a flight plan for that aircraft. | FLIGHT PLAN NOT HELD | L | L | N |
| 163 | Notification to the pilot of an ATSU identifier. | (<i>facility designation</i>) | L | N | N |
| 227 | Confirmation to the aircraft system that the ground system has received the message to which the logical acknowledgement refers and found it acceptable for display to the responsible person. | LOGICAL ACKNOWLEDGEMENT | N | M | N |
| 233 | Notification to the pilot that messages sent requiring a logical acknowledgement will not be accepted by this ground system. | USE OF LOGICAL ACKNOWLEDGEMENT PROHIBITED | N | M | N |

Table A5-12. Additional messages (uplink)

| | <i>Message intent/use</i> | <i>Message element</i> | <i>URG</i> | <i>ALRT</i> | <i>RESP</i> |
|-----|---|------------------------|------------|-------------|-------------|
| 164 | The associated instruction may be complied with at any future time. | WHEN READY | L | N | N |
| 230 | The associated instruction is to be complied with immediately. | IMMEDIATELY | D | H | N |
| 165 | Used to link two messages, indicating the proper order of execution of clearances/instructions. | THEN | L | N | N |

| | <i>Message intent/use</i> | <i>Message element</i> | <i>URG</i> | <i>ALRT</i> | <i>RESP</i> |
|-----|--|--|------------|-------------|-------------|
| 166 | The associated instruction is issued due to traffic considerations. | DUE TO (<i>traffic type</i>) TRAFFIC | L | N | N |
| 167 | The associated instruction is issued due to airspace restrictions. | DUE TO AIRSPACE RESTRICTION | L | N | N |
| 168 | The indicated communication should be ignored. | DISREGARD | U | M | R |
| 176 | Notification that the pilot is responsible for maintaining separation from other traffic and is also responsible for maintaining visual meteorological conditions. | MAINTAIN OWN SEPARATION AND VMC | N | M | W/U |
| 177 | Used in conjunction with a clearance/instruction to indicate that the pilot may execute when prepared to do so. | AT PILOTS DISCRETION | L | L | N |
| 178 | (reserved) | | L | L | Y |
| 169 | | (<i>free text</i>) | N | L | R |
| 170 | | (<i>free text</i>) | D | H | R |
| 183 | | (<i>free text</i>) | N | M | N |
| 187 | | (<i>free text</i>) | L | N | N |
| 194 | | (<i>free text</i>) | N | L | Y |
| 195 | | (<i>free text</i>) | L | L | R |
| 196 | | (<i>free text</i>) | N | M | W/U |
| 197 | | (<i>free text</i>) | U | M | W/U |
| 198 | | (<i>free text</i>) | D | H | W/U |
| 199 | | (<i>free text</i>) | N | L | N |
| 201 | Not used | | L | L | N |
| 202 | Not used | | L | L | N |
| 203 | | (<i>free text</i>) | N | M | R |
| 204 | | (<i>free text</i>) | N | M | Y |
| 205 | | (<i>free text</i>) | N | M | A/N |
| 206 | | (<i>free text</i>) | L | N | Y |
| 207 | | (<i>free text</i>) | L | L | Y |
| 208 | | (<i>free text</i>) | L | L | N |

Note.— Free text message elements have no associated message intent. The capability to send a free text message with any of the attribute combinations already used in the message set has been provided for in the technical requirements of the ATN (Annex 10, Volume III, Part I, Chapter 3).

2. Downlink messages

Table A5-13. Responses (downlink)

| | <i>Message intent/use</i> | <i>Message element</i> | <i>URG</i> | <i>ALRT</i> | <i>RESP</i> |
|---|--|------------------------|------------|-------------|-------------|
| 0 | The instruction is understood and will be complied with. | WILCO | N | M | N |
| 1 | The instruction cannot be complied with. | UNABLE | N | M | N |
| 2 | Wait for a reply. | STANDBY | N | M | N |
| 3 | Message received and understood. | ROGER | N | M | N |
| 4 | Yes. | AFFIRM | N | M | N |
| 5 | No. | NEGATIVE | N | M | N |

Table A5-14. Vertical requests (downlink)

| | <i>Message intent/use</i> | <i>Message element</i> | <i>URG</i> | <i>ALRT</i> | <i>RESP</i> |
|----|--|---|------------|-------------|-------------|
| 6 | Request to fly at the specified level. | REQUEST (<i>level</i>) | N | L | Y |
| 7 | Request to fly at a level within the specified vertical range. | REQUEST BLOCK (<i>level</i>) TO (<i>level</i>) | N | L | Y |
| 8 | Request to cruise climb to the specified level. | REQUEST CRUISE CLIMB TO (<i>level</i>) | N | L | Y |
| 9 | Request to climb to the specified level. | REQUEST CLIMB TO (<i>level</i>) | N | L | Y |
| 10 | Request to descend to the specified level. | REQUEST DESCENT TO (<i>level</i>) | N | L | Y |
| 11 | Request that at the specified position a climb to the specified level be approved. | AT (<i>position</i>) REQUEST CLIMB TO (<i>level</i>) | N | L | Y |
| 12 | Request that at the specified position a descent to the specified level be approved. | AT (<i>position</i>) REQUEST DESCENT TO (<i>level</i>) | N | L | Y |
| 13 | Request that at the specified time a climb to the specified level be approved. | AT (<i>time</i>) REQUEST CLIMB TO (<i>level</i>) | N | L | Y |
| 14 | Request that at the specified time a descent to the specified level be approved. | AT (<i>time</i>) REQUEST DESCENT TO (<i>level</i>) | N | L | Y |
| 69 | Request that a descent be approved on a see-and-avoid basis. | REQUEST VMC DESCENT | N | L | Y |

Note.— Wherever the variable “level” is specified, the message can specify either a single level or a vertical range, i.e. block level.

Table A5-15. Lateral offset requests (downlink)

| | <i>Message intent/use</i> | <i>Message element</i> | <i>URG</i> | <i>ALRT</i> | <i>RESP</i> |
|----|---|---|------------|-------------|-------------|
| 15 | Request that a parallel track, offset from the cleared track by the specified distance in the specified direction, be approved. | REQUEST OFFSET (<i>specified distance</i>) (<i>direction</i>) OF ROUTE | N | L | Y |
| 16 | Request that a parallel track, offset from the cleared track by the specified distance in the specified direction, be approved from the specified position. | AT (<i>position</i>) REQUEST OFFSET (<i>specified distance</i>) (<i>direction</i>) OF ROUTE | N | L | Y |
| 17 | Request that a parallel track, offset from the cleared track by the specified distance in the specified direction, be approved from the specified time. | AT (<i>time</i>) REQUEST OFFSET (<i>specified distance</i>) (<i>direction</i>) OF ROUTE | N | L | Y |

Table A5-16. Speed requests (downlink)

| | <i>Message intent/use</i> | <i>Message element</i> | <i>URG</i> | <i>ALRT</i> | <i>RESP</i> |
|----|--|---|------------|-------------|-------------|
| 18 | Request to fly at the specified speed. | REQUEST (<i>speed</i>) | N | L | Y |
| 19 | Request to fly within the specified speed range. | REQUEST (<i>speed</i>) TO (<i>speed</i>) | N | L | Y |

Table A5-17. Voice contact requests (downlink)

| | <i>Message intent/use</i> | <i>Message element</i> | <i>URG</i> | <i>ALRT</i> | <i>RESP</i> |
|----|---|---|------------|-------------|-------------|
| 20 | Request for voice contact. | REQUEST VOICE CONTACT | N | L | Y |
| 21 | Request for voice contact on the specified frequency. | REQUEST VOICE CONTACT (<i>frequency</i>) | N | L | Y |

Table A5-18. Route modification requests (downlink)

| | <i>Message intent/use</i> | <i>Message element</i> | <i>URG</i> | <i>ALRT</i> | <i>RESP</i> |
|----|--|---|------------|-------------|-------------|
| 22 | Request to track from the present position direct to the specified position. | REQUEST DIRECT TO (<i>position</i>) | N | L | Y |
| 23 | Request for the specified procedure clearance. | REQUEST (<i>procedure name</i>) | N | L | Y |
| 24 | Request for a route clearance. | REQUEST CLEARANCE (<i>route clearance</i>) | N | L | Y |

| | <i>Message intent/use</i> | <i>Message element</i> | <i>URG</i> | <i>ALRT</i> | <i>RESP</i> |
|----|--|--|------------|-------------|-------------|
| 25 | Request for a clearance. | REQUEST (<i>clearance type</i>) CLEARANCE | N | L | Y |
| 26 | Request for a weather deviation to the specified position via the specified route. | REQUEST WEATHER DEVIATION TO (<i>position</i>) VIA (<i>route clearance</i>) | N | M | Y |
| 27 | Request for a weather deviation up to the specified distance off track in the specified direction. | REQUEST WEATHER DEVIATION UP TO (<i>specified distance</i>) (<i>direction</i>) OF ROUTE | N | M | Y |
| 70 | Request a clearance to adopt the specified heading. | REQUEST HEADING (<i>degrees</i>) | N | L | Y |
| 71 | Request a clearance to adopt the specified ground track. | REQUEST GROUND TRACK (<i>degrees</i>) | N | L | Y |

Table A5-19. Reports (downlink)

| | <i>Message intent/use</i> | <i>Message element</i> | <i>URG</i> | <i>ALRT</i> | <i>RESP</i> |
|-----|---|---|------------|-------------|-------------|
| 28 | Notification of leaving the specified level. | LEAVING (<i>level</i>) | N | L | N |
| 29 | Notification of climbing to the specified level. | CLIMBING TO (<i>level</i>) | N | L | N |
| 30 | Notification of descending to the specified level. | DESCENDING TO (<i>level</i>) | N | L | N |
| 31 | Notification of passing the specified position. | PASSING (<i>position</i>) | N | L | N |
| 78 | Notification that at the specified time the aircraft's position was as specified. | AT (<i>time</i>) (<i>distance</i>) (<i>to/from</i>) (<i>position</i>) | N | L | N |
| 32 | Notification of the present level. | PRESENT LEVEL (<i>level</i>) | N | L | N |
| 33 | Notification of the present position. | PRESENT POSITION (<i>position</i>) | N | L | N |
| 34 | Notification of the present speed. | PRESENT SPEED (<i>speed</i>) | N | L | N |
| 113 | Notification of the requested speed. | (<i>speed type</i>) (<i>speed type</i>) (<i>speed type</i>) SPEED (<i>speed</i>) | N | L | N |
| 35 | Notification of the present heading in degrees. | PRESENT HEADING (<i>degrees</i>) | N | L | N |
| 36 | Notification of the present ground track in degrees. | PRESENT GROUND TRACK (<i>degrees</i>) | N | L | N |
| 37 | Notification that the aircraft is maintaining the specified level. | MAINTAINING (<i>level</i>) | N | L | N |
| 72 | Notification that the aircraft has reached the specified level. | REACHING (<i>level</i>) | N | L | N |
| 76 | Notification that the aircraft has reached a level within the specified vertical range. | REACHING BLOCK (<i>level</i>) TO (<i>level</i>) | N | L | N |

| | <i>Message intent/use</i> | <i>Message element</i> | <i>URG</i> | <i>ALRT</i> | <i>RESP</i> |
|-----|---|--|------------|-------------|-------------|
| 38 | Read-back of the assigned level. | ASSIGNED LEVEL (<i>level</i>) | N | M | N |
| 77 | Read-back of the assigned vertical range. | ASSIGNED BLOCK (<i>level</i>) TO (<i>level</i>) | N | M | N |
| 39 | Read-back of the assigned speed. | ASSIGNED SPEED (<i>speed</i>) | N | M | N |
| 40 | Read-back of the assigned route. | ASSIGNED ROUTE (<i>route clearance</i>) | N | M | N |
| 41 | The aircraft has regained the cleared route. | BACK ON ROUTE | N | M | N |
| 42 | The next waypoint is the specified position. | NEXT WAYPOINT (<i>position</i>) | N | L | N |
| 43 | The ETA at the next waypoint is as specified. | NEXT WAYPOINT ETA (<i>time</i>) | N | L | N |
| 44 | The next but one waypoint is the specified position. | ENSUING WAYPOINT (<i>position</i>) | N | L | N |
| 45 | Clarification of previously reported waypoint passage. | REPORTED WAYPOINT (<i>position</i>) | N | L | N |
| 46 | Clarification of time over previously reported waypoint. | REPORTED WAYPOINT (<i>time</i>) | N | L | N |
| 47 | The specified (SSR) code has been selected. | SQUAWKING (<i>code</i>) | N | L | N |
| 48 | Position report. | POSITION REPORT (<i>position report</i>) | N | M | N |
| 79 | The code of the latest ATIS received is as specified. | ATIS (<i>atis code</i>) | N | L | N |
| 89 | The specified ATS unit is being monitored on the specified frequency. | MONITORING (<i>unit name</i>) (<i>frequency</i>) | U | M | N |
| 102 | Used to report that an aircraft has landed. | LANDING REPORT | N | N | N |
| 104 | Notification of estimated time of arrival at the specified position. | ETA (<i>position</i>) (<i>time</i>) | L | L | N |
| 105 | Notification of the alternative aerodrome for landing. | ALTERNATE AERODROME (<i>airport</i>) | L | L | N |
| 106 | Notification of the preferred level. | PREFERRED LEVEL (<i>level</i>) | L | L | N |
| 109 | Notification of the preferred time to commence descent for approach. | TOP OF DESCENT (<i>time</i>) | L | L | N |
| 110 | Notification of the preferred position to commence descent for approach. | TOP OF DESCENT (<i>position</i>) | L | L | N |
| 111 | Notification of the preferred time and position to commence descent for approach. | TOP OF DESCENT (<i>time</i>) (<i>position</i>) | L | L | N |

Note.— Wherever the variable “level” is specified, the message can specify either a single level or a vertical range, i.e. block level.

Table A5-20. Negotiation requests (downlink)

| | <i>Message intent/use</i> | <i>Message element</i> | <i>URG</i> | <i>ALRT</i> | <i>RESP</i> |
|----|--|--|------------|-------------|-------------|
| 49 | Request for the earliest time at which a clearance to the specified speed can be expected. | WHEN CAN WE EXPECT (<i>speed</i>) | L | L | Y |
| 50 | Request for the earliest time at which a clearance to a speed within the specified range can be expected. | WHEN CAN WE EXPECT (<i>speed</i>) TO (<i>speed</i>) | L | L | Y |
| 51 | Request for the earliest time at which a clearance to regain the planned route can be expected. | WHEN CAN WE EXPECT BACK ON ROUTE | L | L | Y |
| 52 | Request for the earliest time at which a clearance to descend can be expected. | WHEN CAN WE EXPECT LOWER LEVEL | L | L | Y |
| 53 | Request for the earliest time at which a clearance to climb can be expected. | WHEN CAN WE EXPECT HIGHER LEVEL | L | L | Y |
| 54 | Request for the earliest time at which a clearance to cruise climb to the specified level can be expected. | WHEN CAN WE EXPECT CRUISE CLIMB TO (<i>level</i>) | L | L | Y |
| 87 | Request for the earliest time at which a clearance to climb to the specified level can be expected. | WHEN CAN WE EXPECT CLIMB TO (<i>level</i>) | L | L | Y |
| 88 | Request for the earliest time at which a clearance to descend to the specified level can be expected. | WHEN CAN WE EXPECT DESCENT TO (<i>level</i>) | L | L | Y |

Note.— Wherever the variable “level” is specified, the message can specify either a single level or a vertical range, i.e. block level.

Table A5-21. Emergency and urgent messages (downlink)

| | <i>Message intent/use</i> | <i>Message element</i> | <i>URG</i> | <i>ALRT</i> | <i>RESP</i> |
|-----|---|--|------------|-------------|-------------|
| 55 | Urgency prefix. | PAN PAN PAN | U | H | Y |
| 56 | Distress prefix. | MAYDAY MAYDAY MAYDAY | D | H | Y |
| 112 | Indicates specifically that the aircraft is being subjected to unlawful interference. | SQUAWKING 7500 | U | H | N |
| 57 | Notification of fuel remaining and number of persons on board. | (<i>remaining fuel</i>) OF FUEL REMAINING AND (<i>persons on board</i>) PERSONS ON BOARD | U | H | Y |
| 58 | Notification that the pilot wishes to cancel the emergency condition. | CANCEL EMERGENCY | U | M | Y |

| | <i>Message intent/use</i> | <i>Message element</i> | <i>URG</i> | <i>ALRT</i> | <i>RESP</i> |
|----|---|---|------------|-------------|-------------|
| 59 | Notification that the aircraft is diverting to the specified position via the specified route due to an urgent need. | DIVERTING TO (<i>position</i>) VIA (<i>route clearance</i>) | U | H | Y |
| 60 | Notification that the aircraft is deviating the specified distance in the specified direction off the cleared route and maintaining a parallel track due to an urgent need. | OFFSETTING (<i>specified distance</i>) (<i>direction</i>) OF ROUTE | U | H | Y |
| 61 | Notification that the aircraft is descending to the specified level due to an urgent need. | DESCENDING TO (<i>level</i>) | U | H | Y |
| 80 | Notification that the aircraft is deviating up to the specified distance from the cleared route in the specified direction due to an urgent need. | DEVIATING UP TO (<i>specified distance</i>) (<i>direction</i>) OF ROUTE | U | H | Y |

Note.— Wherever the variable “level” is specified, the message can specify either a single level or a vertical range, i.e. block level.

Table A5-22. System management messages (downlink)

| | <i>Message intent/use</i> | <i>Message element</i> | <i>URG</i> | <i>ALRT</i> | <i>RESP</i> |
|-----|--|------------------------------------|------------|-------------|-------------|
| 62 | A system-generated message that the avionics has detected an error. | ERROR (<i>error information</i>) | U | L | N |
| 63 | A system-generated denial to any CPDLC message sent from a ground facility that is not the current data authority. | NOT CURRENT DATA AUTHORITY | L | L | N |
| 99 | A system-generated message to inform a ground facility that it is now the current data authority. | CURRENT DATA AUTHORITY | L | L | N |
| 64 | Notification to the ground system that the specified ATSU is the current data authority. | (<i>facility designation</i>) | L | L | N |
| 107 | A system-generated message sent to a ground system that tries to connect to an aircraft when a current data authority has not designated the ground system as the NDA. | NOT AUTHORIZED NEXT DATA AUTHORITY | L | L | N |
| 73 | A system-generated message indicating the software version number. | (<i>version number</i>) | L | L | N |

| | <i>Message intent/use</i> | <i>Message element</i> | <i>URG</i> | <i>ALRT</i> | <i>RESP</i> |
|-----|--|----------------------------|------------|-------------|-------------|
| 100 | Confirmation to the ground system that the aircraft system has received the message to which the logical acknowledgement refers and found it acceptable for display to the responsible person. | LOGICAL ACKNOWLEDGEMENT | N | M | N |

Table A5-23. Additional messages (downlink)

| | <i>Message intent/use</i> | <i>Message element</i> | <i>URG</i> | <i>ALRT</i> | <i>RESP</i> |
|-----|--|--|------------|-------------|-------------|
| 65 | Used to explain reasons for pilot's message. | DUE TO WEATHER | L | L | N |
| 66 | Used to explain reasons for pilot's message. | DUE TO AIRCRAFT PERFORMANCE | L | L | N |
| 74 | States a desire by the pilot to provide his/her own separation and remain in VMC. | REQUEST TO MAINTAIN OWN SEPARATION AND VMC | L | L | Y |
| 75 | Used in conjunction with another message to indicate that the pilot wishes to execute request when the pilot is prepared to do so. | AT PILOTS DISCRETION | L | L | N |
| 101 | Allows the pilot to indicate a desire for termination of CPDLC service with the current data authority. | REQUEST END OF SERVICE | L | L | Y |
| 103 | Allows the pilot to indicate that he/she has cancelled IFR flight plan. | CANCELLING IFR | N | L | Y |
| 108 | Notification that de-icing action has been completed. | DE-ICING COMPLETE | L | L | N |
| 67 | | <i>(free text)</i> | N | L | N |
| 68 | | <i>(free text)</i> | D | H | Y |
| 90 | | <i>(free text)</i> | N | M | N |
| 91 | | <i>(free text)</i> | N | L | Y |
| 92 | | <i>(free text)</i> | L | L | Y |
| 93 | | <i>(free text)</i> | U | H | N |
| 94 | | <i>(free text)</i> | D | H | N |
| 95 | | <i>(free text)</i> | U | M | N |
| 96 | | <i>(free text)</i> | U | L | N |
| 97 | | <i>(free text)</i> | L | L | N |
| 98 | | <i>(free text)</i> | N | N | N |

Note.— Free text message elements have no associated message intent. The capability to send a free text message with any of the attribute combinations already used in the message set has been provided for in the technical requirements of the ATN (Annex 10, Volume III, Part I, Chapter 3).

Table A5-24. Negotiation responses (downlink)

| | <i>Message intent/use</i> | <i>Message element</i> | <i>URG</i> | <i>ALRT</i> | <i>RESP</i> |
|----|--|---|------------|-------------|-------------|
| 81 | We can accept the specified level at the specified time. | WE CAN ACCEPT (<i>level</i>) AT (<i>time</i>) | L | L | N |
| 82 | We cannot accept the specified level. | WE CANNOT ACCEPT (<i>level</i>) | L | L | N |
| 83 | We can accept the specified speed at the specified time. | WE CAN ACCEPT (<i>speed</i>) AT (<i>time</i>) | L | L | N |
| 84 | We cannot accept the specified speed. | WE CANNOT ACCEPT (<i>speed</i>) | L | L | N |
| 85 | We can accept a parallel track offset the specified distance in the specified direction at the specified time. | WE CAN ACCEPT (<i>specified distance</i>) (<i>direction</i>) AT (<i>time</i>) | L | L | N |
| 86 | We cannot accept a parallel track offset the specified distance in the specified direction. | WE CANNOT ACCEPT (<i>specified distance</i>) (<i>direction</i>) | L | L | N |

Note.— Wherever the variable “level” is specified, the message can specify either a single level or a vertical range, i.e. block level.

— END —